

## Front Suspension:

Reset Forms

<b>Ride Height:</b>	17 mm
<b>Camber:</b>	-1°
<b>Toe:</b>	0°
<b>Arm Type:</b>	#91674 Gullwing, Hard
<b>Tower Type:</b>	#91768 Gullwing
<b>Caster Block Insert:</b>	5°
<b>Steering Block:</b>	4
<b>Bulkhead Type:</b>	#91659 Brass
<b>Kick-Up Angle:</b>	25°
<b>Wheel Hex:</b>	#91682 Aluminum
<b>Notes:</b>	#1366 FT Aluminum Servo Horn, 25T #91669 FT Aluminum Steering Rack #91668 Aluminum Steering Bellcranks

**Anti Roll Bar:**

White (0.8mm)

Gray (0.9mm)

Blue (1.0mm)

Other:

**Bump Steer Spacing:** 0 mm

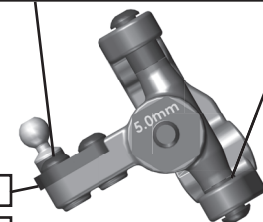

**Axle Height:**

+3

+2

+1

0

**Ball Stud Spacing:** 2 mm

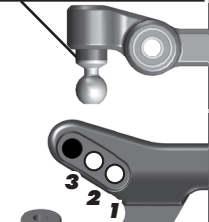

**Steering Plate:** #91680 +1

**Steering Stop Spacing:** 0 mm

**Caster Block Spacing:** 1 mm

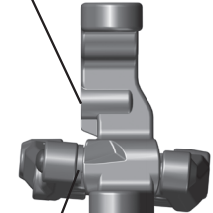

**Ball Stud Spacing:** 2 mm

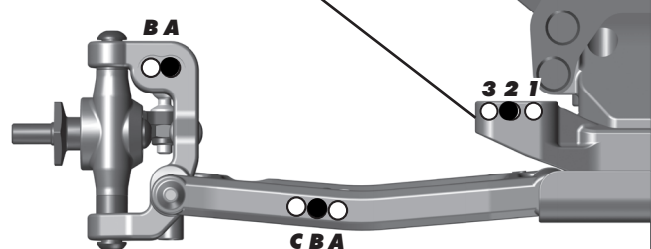

## Rear Suspension:

<b>Ride Height:</b>	18 mm
<b>Camber:</b>	-1°
<b>Tower Type:</b>	#91770 Tall
<b>Wheel Hex:</b>	#91610 FT 7.0 mm
<b>CVA Bone Length:</b>	#91434 67 mm
<b>CVA Pin Location:</b>	Towards Hex
<b>Hub Spacing:</b>	Forward <input type="checkbox"/> Middle <input checked="" type="checkbox"/> Back <input type="checkbox"/>
<b>Shock Mounting Position:</b>	Front of Arm <input checked="" type="checkbox"/> Rear of Arm <input type="checkbox"/>
<b>Notes:</b>	#91777 B6.1 Rear Suspension Arms

**Anti Roll Bar:**

White (1.2mm)



Gray (1.3mm)

Blue (1.4mm)

Other:

**Rear Hub Link Setting:**

Plastic Hub  Aluminum Hub  Ball Stud Spacing: \_\_\_\_\_

Up  Down 



**C Mount Inserts:** 1°  0.5°

Aluminum  Brass

**D Mount Inserts:** 1°  0.5°

Aluminum  Brass

**Hub Insert:**

+3  +2  +1  0

**Ball Stud Spacing:** 3 mm

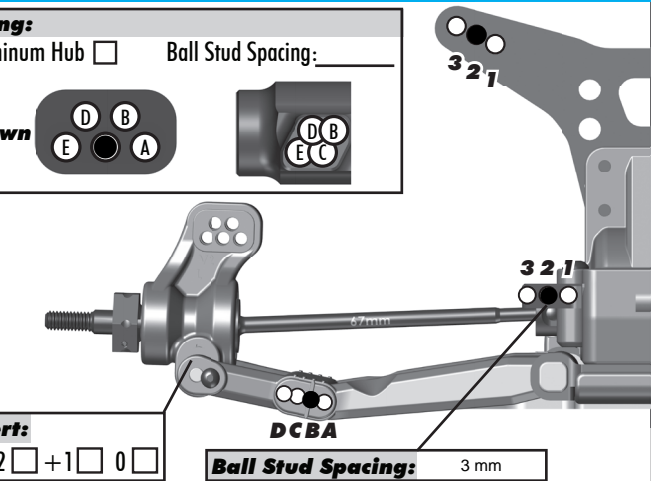

## Electronics:

<b>Radio:</b>	KO PROPO	<b>Servo:</b>	#27100 Reedy RT1206
<b>EPA: Throttle:</b>	100 %	<b>Brake:</b>	95 %
<b>ESC:</b>	LRP Flow X		
<b>ESC Settings:</b>	N/A		
<b>Motor:</b>	Reedy M3 (#275 12.5mm Mod Rotor)		
<b>Wind:</b>	6.5	<b>Timing:</b>	35°
<b>Pinion:</b>	23	<b>Spur:</b>	81
<b>Battery:</b>	#27325 Reedy Zapper 4000 SG LP		
<b>Battery Position:</b>	5F		

## Drivetrains:

<b>Transmission:</b>	<b>Laydown:</b> <input checked="" type="checkbox"/>
<b>3 Gear:</b> <input checked="" type="checkbox"/>	<b>Layback:</b> <input type="checkbox"/>
<b>4 Gear:</b> <input type="checkbox"/>	<b>Stand Up:</b> <input type="checkbox"/>
<b>Differential:</b>	<b>Ball Diff:</b> <input type="checkbox"/>
<b>Height:</b> 2	<b>Gear Diff:</b> <input checked="" type="checkbox"/>
<b>Notes:</b>	6,000 - 4 Gear

## Slipper Clutch:

<b>Type:</b>	Team Associated
<b># of Pads:</b>	2 x #91197 LCF

## Shocks:

	Front	Rear
<b>Piston:</b>	2 x 1.6 TMG	2 x 1.7 TMG
<b>Fluid:</b>	37.5 wt	27.5 wt
<b>Spring:</b>	#91835 V2 Red	#91838 V2 White
<b>Limiters:</b>	0	0
<b>Stroke:</b>	21.0 mm	27.5 mm
<b>Eyelet Length:</b>	Long	Long
<b>Cup Offset:</b>	5 mm	5 mm
<b>Notes:</b>	#91494 Machined Shock Spacers V2	



## Track Info:

<b>Size:</b>	Small <input type="checkbox"/> Medium <input type="checkbox"/> Large <input checked="" type="checkbox"/> Extra Large <input type="checkbox"/>
<b>Surface:</b>	Dirt <input type="checkbox"/> Carpet <input type="checkbox"/> AstroTurf <input checked="" type="checkbox"/> Multi Surface <input type="checkbox"/>
<b>Traction:</b>	Low <input type="checkbox"/> Medium <input checked="" type="checkbox"/> High <input checked="" type="checkbox"/> Very High <input checked="" type="checkbox"/>
<b>Moisture:</b>	Dry <input checked="" type="checkbox"/> Damp <input type="checkbox"/> Wet <input type="checkbox"/>
<b>Condition:</b>	Indoor <input type="checkbox"/> Outdoor <input checked="" type="checkbox"/> Dusty <input type="checkbox"/> Hard Packed <input type="checkbox"/> Bumpy <input checked="" type="checkbox"/> Grooved <input type="checkbox"/> Smooth <input type="checkbox"/> Loamy <input type="checkbox"/>
<b>Temperature:</b>	Ambient: _____ Track: _____
<b>Notes:</b>	

## Tires:

<b>Front Tires:</b>	Schumacher Stagger Cut
<b>Front Compound:</b>	Yellow
<b>Front Insert:</b>	None
<b>Rear Tires:</b>	Schumacher Mini Darts
<b>Rear Compound:</b>	Yellow
<b>Rear Insert:</b>	KWF
<b>Wheel (F/R):</b>	Team Associated
<b>Notes:</b>	

## Body, Wing, Weight:

<b>Body:</b>	Pro-Line Elite (Lightweight)
<b>Wing:</b>	PL Lower Front Wing / #91741 B6 Wing
<b>Wing Angle:</b>	0° <input type="checkbox"/> 3° <input type="checkbox"/> 6° <input checked="" type="checkbox"/>
<b>Servo Weights:</b>	None <input type="checkbox"/> Aluminum <input type="checkbox"/> Steel <input checked="" type="checkbox"/> Other <input type="checkbox"/>
<b>Electronic Weights:</b>	None <input type="checkbox"/> Aluminum <input type="checkbox"/> Steel <input checked="" type="checkbox"/> Other <input type="checkbox"/>
<b>Total Vehicle Weight:</b>	1575g

## Vehicle Comments:

**Notes:** #91755 Ti Screw Kit (only used above chassis); #91652 Side Rails, Standard; #91697 & 91620 Chrome Shock Shafts; #91576 & 91578 Fox Shock Bodies; #27304 Reedy Battery Weight (22 + 34 g)