

Front Suspensions:

Camber: -1

Total Toe: +1/2

Ride Height: 23 mm

Arm Type: Flat, Hard #91399

Tower Type: Flat, Standard #91374

Caster Block Insert: 5

Kick-Up Angle: 25° Aluminum #91367

Wheel Hex: Factory Team Aluminum #91411

Notes: Top Plate, Standard #91362

Chassis Plate, Standard #91512

Caster Blocks, Standard #91400 & Steering Blocks, Standard #91404

Steering Set, Plastic #91391

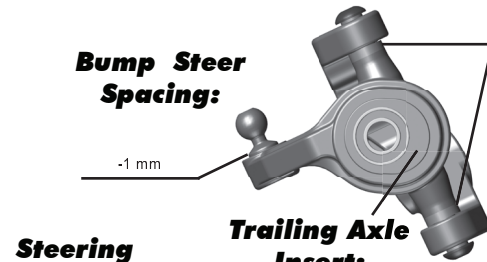

Axle Height:

Up

Middle

Down

Ball Stud Spacing: 1 mm

Steering Stop Spacing:

0 2mm 3mm 4mm

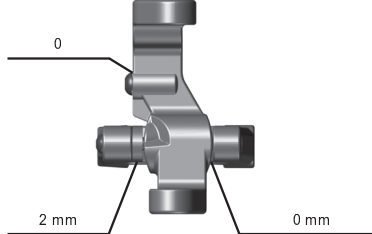

Caster Block Spacing:

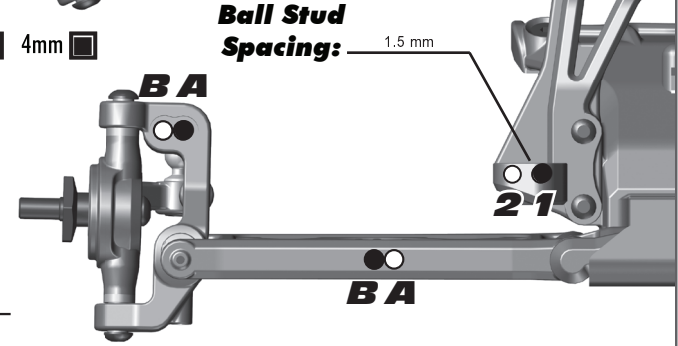

Rear Suspension:

Camber: -1

Ride Height: 23 mm

Wheel Hex: Clamping, 7mm #91610

Hub Spacing:

Forward Middle Back

Notes: B5 Rear Arms, Hard #91413

Factory Team Aluminum Hubs #91549 (Back Row Inside +3mm)

Aluminum "C" #91522 & Aluminum "D" #91524 Arm Mounts

Heavy Duty CVA Kit #91612

Anti Roll Bar:

None

Black (1.2mm)

Silver (1.3mm)

Gold (1.4mm)

Rear Hub Link Setting:

A Up Down

B Up Down



Arm Mount:

Inboard Toe: 3

Anti-Squat: 1

Insert (D): Arrows In

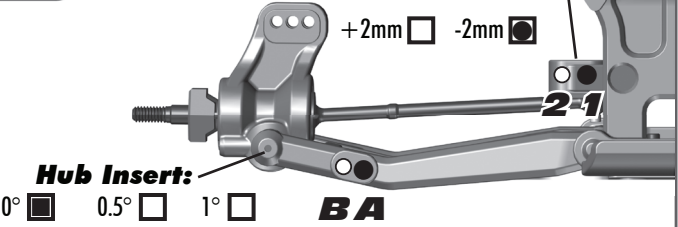

Electronics:

Radio: KO ProPo **Servo:** Reedy 1208

EPA: Throttle: 100 % **Brake:** 100 %

ESC: Reedy Blackbox 410R (BEC Voltage 6.0v)

ESC Settings: N/A

Motor: Reedy Sonic M3

Wind: 7.5 **Timing:** 26

Pinion: 24 **Spur:** 81

Battery: Reedy 5300 mAh #322

Battery Position: Battery 8mm From Back & Taped In

Drivetrain:

Differential:

3 Gear: **4 Gear:**

Ball Diff: **Gear Diff:**

Notes: Tight

Slipper Clutch:

Type: Associated V2 Slipper Plates #7495

of Pads: 2

Notes: B44 Slipper Spring #9739

Shocks:

	Front	Rear
Piston:	2 x 1.6 Flat V2	4 x 1.4 Flat V2
Oil:	30 wt	32.5 wt
Spring:	White	White
Limiters:	2	2
Cup Offset:	5 mm	5 mm
Stroke:	20.5 mm	27.5 mm
Free Length:	N/A	N/A
Notes:	X-Rings #91493	

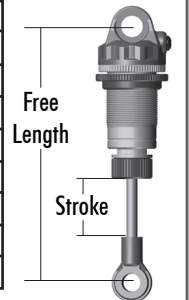

Track Info:

Size: Small Medium Large Extra Large

Surfaces: Dirt Carpet Astroturf Multi Surface

Traction: Low Medium High Very High

Moisture: Dry Damp Wet

Condition: Indoor Outdoor Dusty Hard Packed

Bumpy Grooved Smooth Loamy

Temperature: Ambient: 70 **Track:** 70

Notes:

Tires:

Tires (F/R): JConcepts Dirt Webs 2.2 / JConcepts Dirt Webs 2.2

Compound (F/R): Gold / Gold

Insert (F/R): Pro-Line Closed Cell / Pro-Line Closed Cell

Wheel (F/R): Team Associated / Team Associated

Notes: Reedy Race Control Sauce

Body, Wing & Chassis:

Body: JConcepts S2

Wing: JConcepts B5M Aero

Wing Angle: 0° 3° 6°

Chassis: **#91510 - B5M** **#91511 - B5M Lite**

Race Results:

Qualify: 1 **Main:** A

Finish: 1 **TQ:**

Best Lap Time:

Vehicle Comments:

Factory Team Bearing Set #91553; Plastic Shock Caps #91449; Shock Bushings, Aluminum #91446; Ti Screw Kit B5M, #91600; Kashima Shock Bodies #91576 & #91578; V2 Chrome Shock Shafts #91616 & #91620; Front pin brace removed & bumper bent up;

Total Vehicle Weight: 1560g