

### Front Suspensions:

**Camber:** -1

**Total Toe:** 0

**Ride Height:** 23 mm

**Arm Type:** #91399 Flat, Hard

**Tower Type:** #91373 Flat, Standard

**Caster Block Insert:** 5

**Kick-Up Angle:** 25

**Wheel Hex:** #91411 Aluminum Axle

**Notes:** #91373 Standard Front Hinge Pin Brace

#91440 Standard Front Caster Blocks

#91404 Standard Steering Blocks

#91362 Standard Top Plate

#91392 Aluminum Steering Set

#91512 Chassis Plate, Standard

#91514 Chassis Cradle, Standard

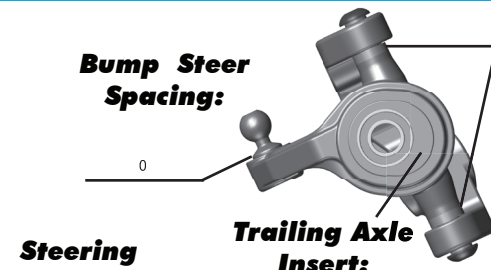

**Axle Height:**

Up

Middle

Down

**Ball Stud Spacing:** 1 mm

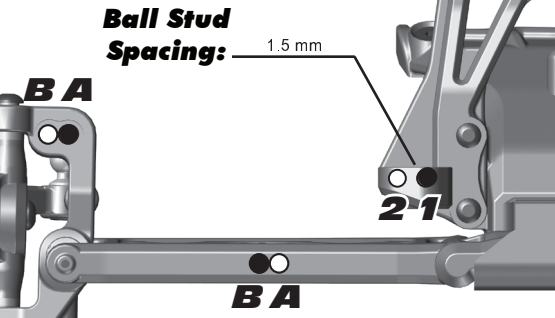
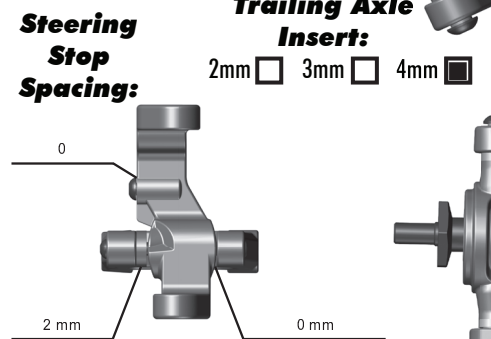

### Rear Suspension:

**Camber:** -1

**Ride Height:** 23 mm

**Wheel Hex:** #91410 Clamping Hex 7.0mm

**Hub Spacing:**

Forward  Middle  Back

**Notes:** #91413 Rear Arms, Hard

#91548 Factory Team 0° Aluminum Hubs (Back Row Inside + 3 mm)

#91522 & #91524 Factory Team Aluminum Arm Mount (C) & (D)

#91518 Standard Rear Tower

**Anti Roll Bar:**

None

Black (1.2mm)

Silver (1.3mm)

Gold (1.4mm)

**Rear Hub Link Setting:**

**A** C A Up  Down

**B** B A Up  Down

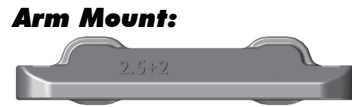

**Arm Mount:**

**Inboard Toe:** 3

**Anti-Squat:** 1

**Insert (D):** Arrow In

**Hub Insert:**

0°  0.5°  1°

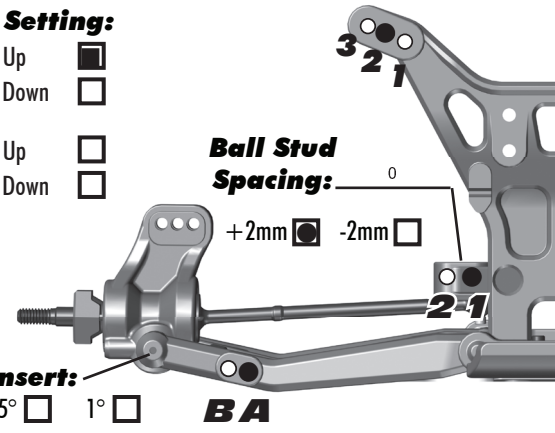

### Electronics:

**Radio:** Airtronics M12 **Servo:** Reedy 1206

**EPA Throttle:** 100 % **Brake:** 90 %

**ESC:** Reedy Blackbox 410R

**ESC Settings:** See Spencer Rivkin Setup Sheet

**Motor:** Reedy Sonic Mach2

**Wind:** 17.5 **Timing:** 46°

**Pinion:** 30 **Spur:** 69

**Battery:** Reedy Lo-Pro 3900mAh #738

**Battery Position:** Middle

### Drivetrain:

**Differential:**

**3 Gear:**  **4 Gear:**

**Ball Diff:**  **Gear Diff:**

**Notes:** Standard

### Slipper Clutch:

**Type:** Associated

**# of Pads:** 2

**Notes:** Tight

### Shocks:

	Front	Rear
<b>Piston:</b>	3 x 1.4 Flat	2 x 1.6 Flat
<b>Oil:</b>	30 wt	27.5 wt
<b>Spring:</b>	White	Green
<b>Limiters:</b>	1	1
<b>Cup Offset:</b>	5 mm	5 mm
<b>Stroke:</b>	21.0 mm	27.0 mm
<b>Free Length:</b>	N/A	N/A
<b>Notes:</b>	#91493 X-Rings; #91450 Aluminum Caps	

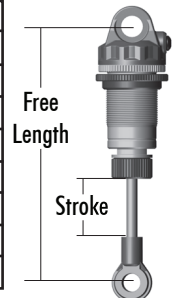

### Track Info:

**Size:** Small  Medium  Large  Extra Large

**Surfaces:** Dirt  Carpet  Astroturf  Multi Surface

**Traction:** Low  Medium  High  Very High

**Moisture:** Dry  Damp  Wet

**Condition:** Indoor  Outdoor  Dusty  Hard Packed

Bumpy  Grooved  Smooth  Loamy

**Temperature:** Ambient: 80° Track: 80°

**Notes:**

### Tires:

**Tires (F/R):** JConcepts Dirt Webs 61mm / JConcepts Dirt Webs 61mm

**Compound (F/R):** Gold / Gold

**Insert (F/R):** Closed Cell / Closed Cell

**Wheel (F/R):** Team Associated Hex 61mm / Team Associated Hex 61mm

**Notes:**

### Body, Wing & Chassis:

**Body:** Team Associated B5M Kit #91538

**Wing:** Team Associated B5M Kit #91471

**Wing Angle:** 0°  3°  6°  Wing Lip Cut To Line

**Chassis:** #91510 - B5M  #91511 - B5M Lite

### Race Results:

**Qualify:** 2 **Main:** A

**Finish:** 2 **TQ:**

**Best Lap Time:** 19.3

### Vehicle Comments:

#90000 B5M Factory Lite Kit; #91600 Factory Team Titanium Screw Kit;

**Total Vehicle Weight:** 1525g