

Front Suspensions:

Camber: -1

Total Toe: 0

Ride Height: 24 mm

Arm Type: #91398 Flat, Standard

Tower Type: #91373 Flat, Standard

Caster Block Insert: 5

Kick-Up Angle: 25

Wheel Hex: JConcepts Clamping Hex

Notes: #91362 Top Plate, Standard

#91401 Caster Block, Hard

#91372 Factory Team Aluminum Front Hinge Pin Brace

#91392 Factory Team Aluminum Steering Set

#91512 Chassis Plate, Standard

#91514 Chassis Cradle, Standard

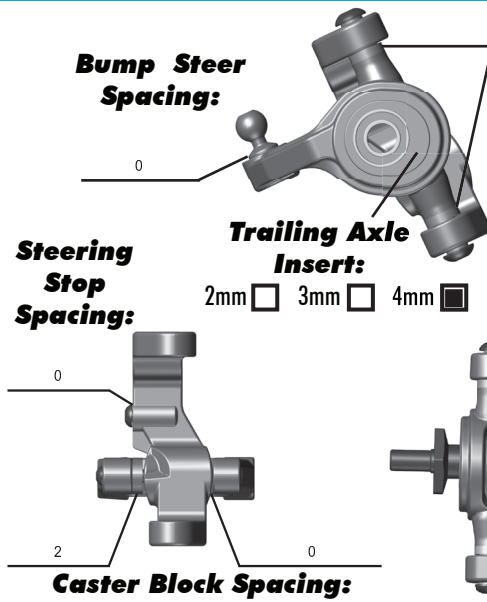

Axle Height:

Up

Middle

Down

Ball Stud Spacing: 2 mm

Ball Stud Spacing: 1 mm

Rear Suspension:

Camber: -1

Ride Height: 24 mm

Wheel Hex: JConcepts Clamping Hex

Hub Spacing: Forward Middle Back

Notes: #91412 Rear Arms, Standard

#91549 Factory Team 0° Aluminum Hubs (Back Row Inside + 3 mm)

#91520 Factory Team Aluminum Camber Link Mount (Plastic + 1 mm)

#91522 & 91524 Factory Team Aluminum "C" and "D" plate

#91518 Rear Tower Mount, Standard

Anti Roll Bar:

None

Black (1.2mm)

Silver (1.3mm)

Gold (1.4mm)

Rear Hub Link Setting:

A C A Up Down

B B A Up Down

Arm Mount:



Inboard Toe: 3

Anti-Squat: 1

Insert (D): Arrow In

Hub Insert: 0° 0.5° 1°

Ball Stud Spacing: 3mm (1mm Plastic)

+2mm -2mm

Electronics:

Radio: Airtronics M12 **Servo:** XP 1015

EPA: Throttle: 100 % **Brake:** 85 %

ESC: Reedy Blackbox 410R

ESC Settings: See Setup Sheet

Motor: Reedy Sonic Mach 2

Wind: 7.5 **Timing:** 20°

Pinion: 24 **Spur:** 81

Battery: Reedy Wolf Pack Shorty #738

Battery Position: 1 Thin Pad Rear / 1 Thin + 1 Thick Front

Drivetrain:

Differential:

3 Gear: **4 Gear:**

Ball Diff: **Gear Diff:**

Notes:

Slipper Clutch:

Type: Team Associated

of Pads: 2

Notes:

Shocks:

	Front	Rear
Piston:	3 x 1.4 Flat	3 x 1.4 Flat
Oil:	32.5 wt	30 wt
Spring:	White	White
Limiters:	1	1
Cup Offset:	5 mm	5 mm
Stroke:	20.5 mm	26.5 mm
Free Length:	N/A	N/A
Notes:	#91493 X-Rings; #91450 Aluminum Caps	

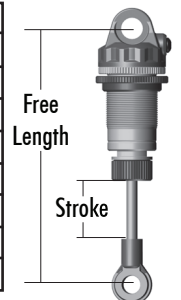

Track Info:

Size: Small Medium Large Extra Large

Surfaces: Dirt Carpet Astroturf Multi Surface

Traction: Low Medium High Very High

Moisture: Dry Damp Wet

Condition: Indoor Outdoor Dusty Hard Packed

Bumpy Grooved Smooth Loamy

Temperature: Ambient: 70° **Track:** 70°

Notes:

Tires:

Tires (F/R): JConcepts Dirt Webs / JConcepts Dirt Webs

Compound (F/R): Green / Green

Insert (F/R): JConcepts Dirt Tech / JConcepts Dirt Tech

Wheel (F/R): JConcepts Mono / JConcepts Mono

Notes: Wash With Simple Green

Body, Wing & Chassis:

Body: JConcepts Finisher

Wing: JConcepts High Flow 6.5°

Wing Angle: 0° 3° 6° Wing Lip Cut To 2 Lines

Chassis: #91510 - B5M #91511 - B5M Lite

Race Results:

Qualify: 1 **Main:** A

Finish: TQ:

Best Lap Time:

Vehicle Comments:

#91551 Factory Team Bearing Set; #91446 Factory Team Shock Bushings; #91547 Factory Team Milled Motor Plate; #91450 Factory Team Aluminum Shock Caps; #91600 Titanium Screw Kit; #91545 Graphite Battery Strap; JConcepts Fin Titanium Turnbuckles

Total Vehicle Weight: