

Front Suspensions:

Camber: -2

Total Toe: + 1/2

Ride Height: 19 mm

Arm Type: Flat, Hard #91399

Tower Type: Flat, Standard #91374

Caster Block Insert: 5*

Kick-Up Angle: 25* Aluminum #91367

Wheel Hex: 4mm Clamping #91409

Notes: Top Plate, Standard #91362

Chassis Plate, Standard #91512

Caster Blocks, Standard #91400

Steering Blocks, Standard #91404

Caster Block Bushings, Offset #91403

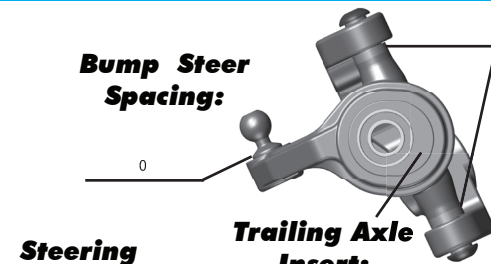

Axle Height:
Up
Middle
Down

Ball Stud Spacing:
0 mm

Steering Stop Spacing:
0 mm

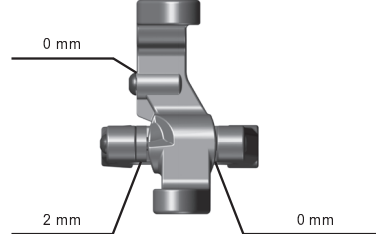

Caster Block Spacing:
2 mm 0 mm

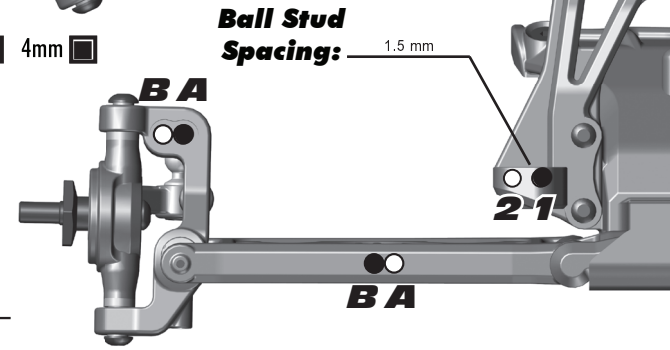

Rear Suspension:

Camber: -1/2

Ride Height: 19 mm

Wheel Hex: 7mm #91610

Hub Spacing:
Forward Middle Back

Notes: B5 Rear Arms, Hard #91412

Factory Team Aluminum Hubs #91549 (Back Row Inside +3mm)

Aluminum "C" #91522 & "D" #91524 Arm Mounts

Anti Roll Bar:
None
Black (1.2mm)
Silver (1.3mm)
Gold (1.4mm)

Rear Hub Link Setting:
A Up
B Down

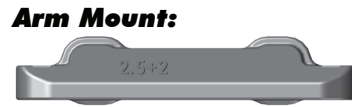

Inboard Toe: 3

Anti-Squat: 1

Insert (D): GHEA +2 mm

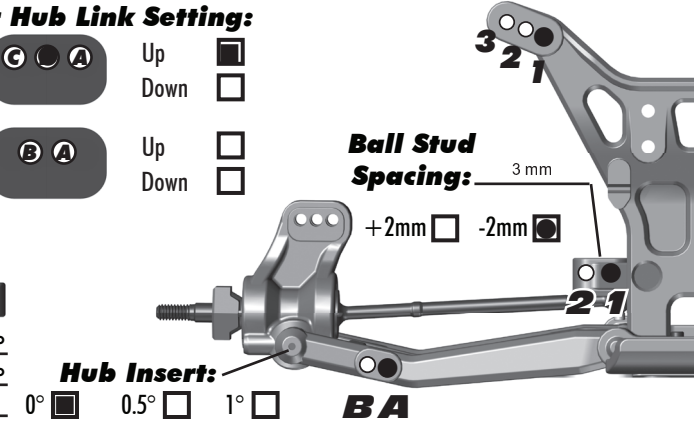

Electronics:

Radio: Airtronic M12S **Servo:** Sanwa 94671

EPA: Throttle: 100 % **Brake:** 100 %

ESC: Team Orion

ESC Settings: N/A

Motor: Team Orion VST2 Lightweight

Wind: 7.5 **Timing:** 0°

Pinion: 22 **Spur:** 81

Battery: Team Orion 4500 Shorty

Battery Position: 9 mm From Rear (Battery Taped In)

Drivetrain:

Differential:
3 Gear: **4 Gear:**

Ball Diff: **Gear Diff:**

Notes: 3,000 Diff Fluid

Slipper Clutch:

Type: Associated V2 Slipper Plates #7495

of Pads: 2

Notes: B44 Slipper Spring #9739

Shocks:

| | Front | Rear |
|---------------------|---|-----------------|
| Piston: | 2 x 1.6 Flat V2 | 3 x 1.4 Flat V2 |
| Oil: | 32.5 wt | 27.5 wt |
| Spring: | Blue | Green |
| Limiters: | 2 | 1 |
| Cup Offset: | 5 mm | 5 mm |
| Stroke: | 20.25 mm | 27.0 mm |
| Free Length: | N/A | N/A |
| Notes: | Kashima Shock Bodies, Chrome V2 Shafts, X-Rings | |

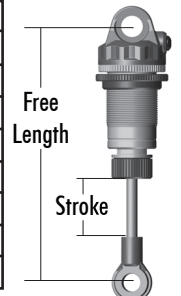

Track Info:

Size: Small Medium Large Extra Large

Surfaces: Dirt Carpet Astroturf Multi Surface

Traction: Low Medium High Very High

Moisture: Dry Damp Wet

Condition: Indoor Outdoor Dusty Hard Packed
Bumpy Grooved Smooth Loamy

Temperature: Ambient: 80F **Track:** 80F

Notes: 100% Clay

Tires:

Tires (F/R): AKA Slicks / AKA Slicks

Compound (F/R): Clay / Clay

Insert (F/R): AKA Black / AKA Black

Wheel (F/R): Team Associated 61mm Hex #91573 / Team Associated 61mm Hex #91571

Notes:

Body, Wing & Chassis:

Body: Team Associated Kit #91538

Wing: Team Associated Kit #91471

Wing Angle: 0° 3° 6° Wing Screwed In; 1mm shim behind lower mount

Chassis: **#91510 - B5M** **#91511 - B5M Lite**

Race Results:

Qualify: 1 **Main:** 1

Finish: 1 **TQ:**

Best Lap Time:

Vehicle Comments:

Factory Team Bearing Set #91553; CVA Axles Shims #91605; Plastic Shock Caps #91449; Shock Bushings, Aluminum #91446; Front wing

Total Vehicle Weight: 1554g