

Front Suspensions:

Camber: -1

Total Toe: -1/2

Ride Height: 23 mm

Arm Type: #91399 Flat, Hard

Tower Type: #91373 Flat, Standard

Caster Block Insert: 5

Kick-Up Angle: 25

Wheel Hex: 4.5 mm

Notes: #91373 Standard Front Hinge Pin Brace

#91440 Standard Front Caster Blocks

#91362 Standard Top Plate

#91392 Aluminum Steering Set

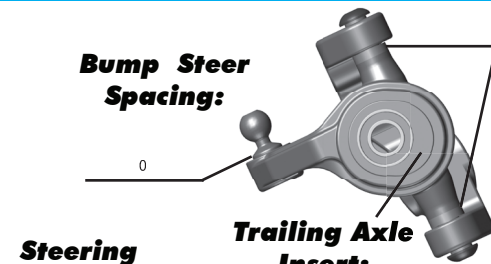

Axle Height:

Up

Middle

Down

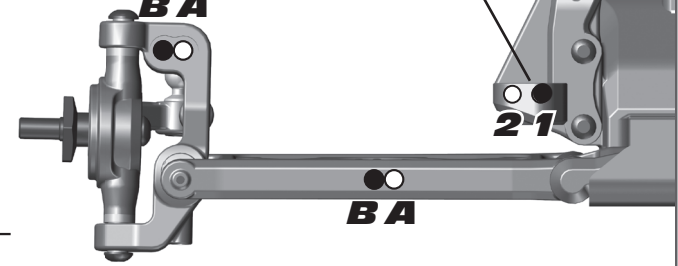
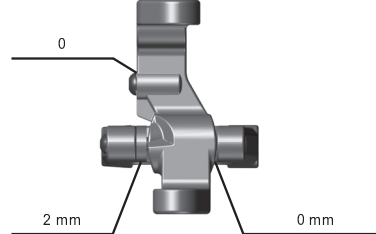
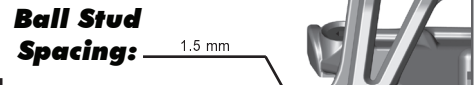

Rear Suspension:

Camber: -1

Ride Height: 23 mm

Wheel Hex: 7.0 mm

Hub Spacing: Forward Middle Back

Notes: #91414 Hard Rear Arms

#91549 Factory Team 0° Aluminum Hubs (Front Row Outside + 3 mm)

#91522 Factory Team Aluminum Arm Mount (C)

#91524 Factory Team Aluminum Arm Mount (D)

#91518 Standard Rear Tower

Anti Roll Bar:

None

Black (1.2mm)

Silver (1.3mm)

Gold (1.4mm)

Rear Hub Link Setting:

A C B A Up Down

B A Up Down

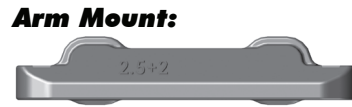

Inboard Toe: 2.5

Anti-Squat: 1

Insert (D): GHEA +2 Pivots

Hub Insert: 0° 0.5° 1°

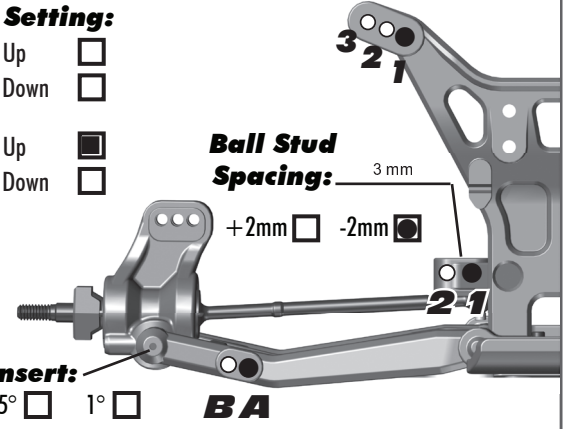

Electronics:

Radio: Airtronics M12 **Servo:** Airtronics

EPA: Throttle: 100 % **Brake:** 95 %

ESC: Team Orion R10.1

ESC Settings: N/A

Motor: Team Orion VST2

Wind: 7.5 **Timing:** 7 Lines

Pinion: 22 **Spur:** 81

Battery: Team Orion 4500mAh

Battery Position: Middle

Drivetrain:

Differential:

3 Gear: **4 Gear:**

Ball Diff: **Gear Diff:**

Notes: 2,000 Diff Fluid

Slipper Clutch:

Type: Associated

of Pads: 2

Notes: #7495 Vented Slipper Plates

Shocks:

	Front	Rear
Piston:	3 x 1.4 Flat Machined	3 x 1.4 Flat Machined
Oil:	35 wt	30 wt
Spring:	AE Green	AE White
Limiters:	2	1
Cup Offset:	5 mm	5 mm
Stroke:	20.5	27.0
Free Length:	N/A	N/A
Notes:	#91493 X-Rings; #91450 Aluminum Caps	

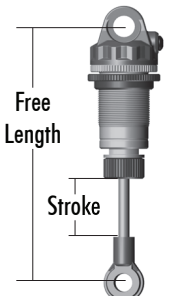

Track Info:

Size: Small Medium Large Extra Large

Surfaces: Dirt Carpet Astroturf Multi Surface

Traction: Low Medium High Very High

Moisture: Dry Damp Wet

Condition: Indoor Outdoor Dusty Hard Packed

Bumpy Grooved Smooth Loamy

Temperature: Ambient: 70° **Track:** 70°

Notes: Some slime patches to start race

Tires:

Tires (F/R): AKA Slicks / AKA Slicks

Compound (F/R): Clay / Clay

Insert (F/R): AKA / AKA

Wheel (F/R): AKA Evo / AKA Evo

Notes:

Body, Wing & Chassis:

Body: Team Associated #91538

Wing: Team Associated Kit #91471

Wing Angle: 0° 3° 6° Wing lip cut to 2 lines; Wing raised 1 shim

Chassis: #91510 - B5M #91511 - B5M Lite

Race Results:

Qualify: 2 **Main:** A

Finish: 2 **TQ:**

Best Lap Time: 19.312

Vehicle Comments:

#91551 Factory Team Bearing Set; #91545 Factory Team Graphite Battery Strap; #91446 Factory Team Shock Bushings; #91602 Factory Team Milled Motor Plate;

Total Vehicle Weight: 1560g