

Front Suspensions:

Camber: 0
Total Toe: 0
Ride Height: 24 mm
Arm Type: Flat, Standard Composite
Tower Type: Flat, Carbon Composite
Caster Block Insert: 5
Kick-Up Angle: 25

Notes: Carbon composite caster block, spindles and tower;
Trail inserts glued in;

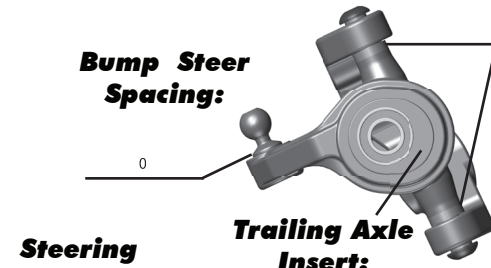

Axle Height:
 Up
 Middle
 Down

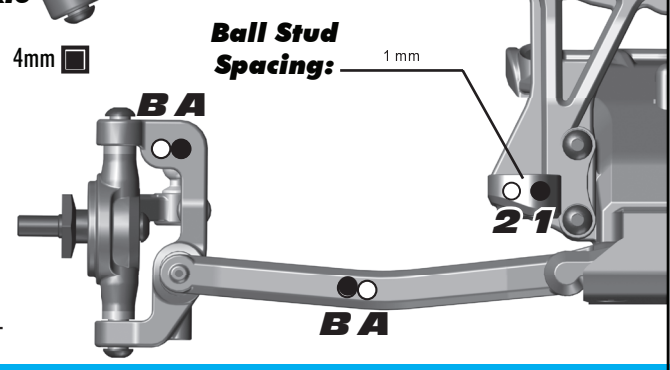
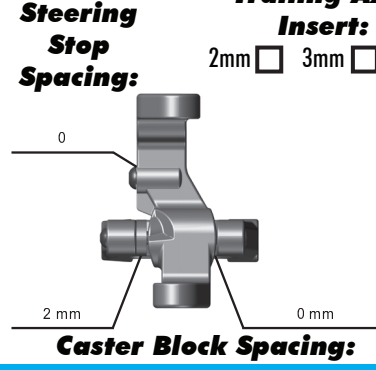

Rear Suspension:

Camber: 0
Ride Height: 24 mm
Hub Spacing: Forward Middle Back

Notes: Factory Team Aluminum Arm Mounts

Anti Roll Bar:
 None
 Black (1.2mm)
 Silver (1.3mm)
 Gold (1.4mm)

Rear Hub Link Setting:
A C B A Up
 Down
B A Up
 Down



Arm Mount:
Inboard Toe: 3
Anti-Squat: 2

Hub Insert: 0° 0.5° 1° BA

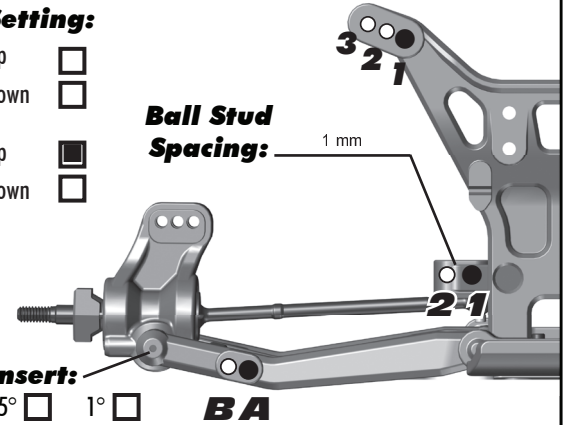

Electronics:

Radio: Airtronics M12 **Servo:** XP 1313
EPA: Throttle: 100 % **Brake:** 89 %
ESC: Reedy Blackbox
ESC Settings: -
Motor: Reedy Sonic Mach2
Wind: 7.5 **Timing:** 0
Pinion: 23 **Spur:** 81
Battery: Reedy Shorty #602
Battery Position: Thick Pad Front / Two Thin Pads Rear

Drivetrain:

Differential:
 Ball:
 Setting: Standard To Tight
 Gear:
 Oil: _____

Slipper Clutch:

Type: Schelle Nova
of Pads: 3
Notes: White / White / Red Pads

Shocks:

	Front	Rear
Piston:	3 x 1.4 Tapered	3 x 1.4 Flat
Oil:	35	32.5
Spring:	White	White
Limiters:	1	1
Cup Offset:	5 mm	5 mm
Stroke:	20.5 mm	26.5 mm
Free Length:	N/A	N/A
Notes:	Factory Team Clear X-Rings	

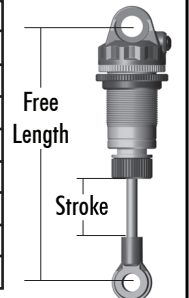

Track Info:

Size: Small Medium Large Extra Large
Surfaces: Dirt Carpet Astroturf Multi Surface
Traction: Low Medium High Very High
Moisture: Dry Damp Wet
Condition: Indoor Outdoor Dusty Hard Packed
 Bumpy Grooved Smooth Loamy

Temperature: Ambient: _____ Track: _____
Notes: Some dust outside of groove

Tires:

Tires (F/R): JConcepts Bar Codes / JConcepts Bar Codes V1
Compound (F/R): Green / Green
Insert (F/R): JConcepts Dirt-Tech Gray / JConcepts Dirt-Tech Gray
Wheel (F/R): JConcepts Mono / JConcepts Mono
Notes: JConcepts Serrated Wheel Nus

Body & Wing:

Body: JConcepts Silencer
Wing: JConcepts B5 High Clearance 6.5" (Wicker lip cut to 1 line)
Wing Angle: 0° 3° 6°
Notes:

Race Results:

Qualify: _____ **Main:** _____
Finish: _____ **TQ:**
Best Lap Time: _____

Vehicle Comments:

Lunsford titanium screws; Transponder on top of servo; Factory Team Aluminum Shock Caps; UpGrade chassis tape;
Total Vehicle Weight: 1620g