

Front Suspensions:

Camber: -1

Total Toe: -1/4

Ride Height: 24 mm

Arm Type: #91399 Flat, Hard

Tower Type: #91374 Flat, Hard

Caster Block Insert: 5

Kick-Up Angle: 25

Notes: #91373 Plastic Front Hinge Pin Brace
#91401 Factory Team Caster Block, Hard

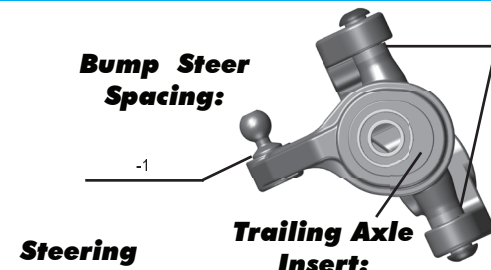

Axle Height:
Up
Middle
Down



Steering Stop Spacing:
0 mm 2 mm 3 mm 4 mm

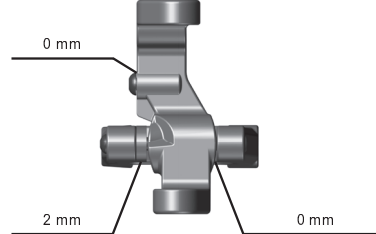

Ball Stud Spacing: 1 mm

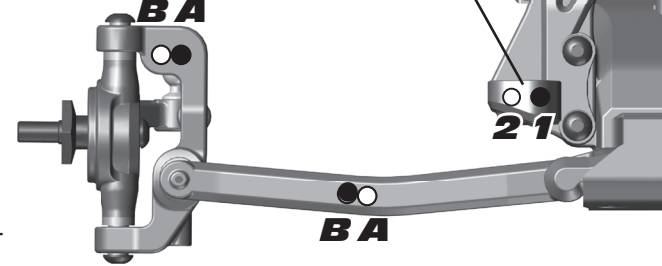

Rear Suspension:

Camber: -1

Ride Height: 24 mm

Hub Spacing:
Forward Middle Back

Notes: #91412 Factory Team Rear Arms, Standard
#91548 Factory Team 0° Aluminum Hubs Front Row Outside + 3 mm)
#91520 Factory Team Aluminum Camber Link Mount (Low + 4 mm)
#91522 & 91524 Factory Team Aluminum "C" and "D" plate

Anti Roll Bar:
None
Black (1.2mm)
Silver (1.3mm)
Gold (1.4mm)

Rear Hub Link Setting:
A C B A
Up
Down
B A
Up
Down



Arm Mount: 3

Inboard Toe: 1

Anti-Squat: 0° 0.5° 1°

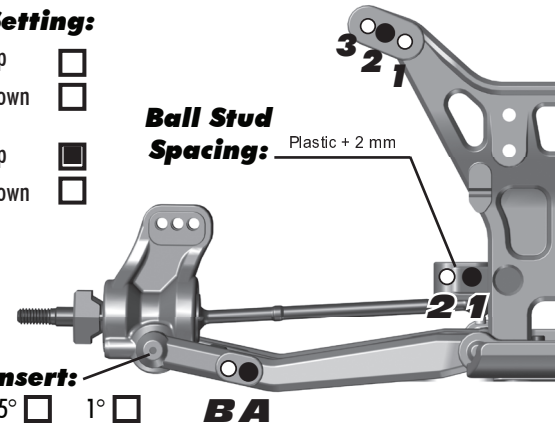

Electronics:

Radio: Airtronics M12 **Servo:** Sanwa 94671

EPA: Throttle: 100 % **Brake:** 92 %

ESC: Team Orion R10.1

ESC Settings: N/A

Motor: Team Orion VST2

Wind: 7.5 **Timing:** N/A

Pinion: 22 **Spur:** 78

Battery: Team Orion Carbon 4000mah shorty

Battery Position: Middle

Drivetrain:

Differential:
Ball:
Setting: Tight

Slipper Clutch:
Type: Associated

of Pads: 2

Notes:

Shocks:

	Front	Rear
Piston:	3 x 1.4 Flat	2 x 1.6 Flat
Oil:	32.5 wt	30 wt
Spring:	Gray	Green
Limiters:	2	2
Cup Offset:	5mm	5mm
Stroke:	20.5 mm	26.5 mm
Free Length:	N/A	N/A
Notes:	Aluminum Shock Caps; X-Rings	

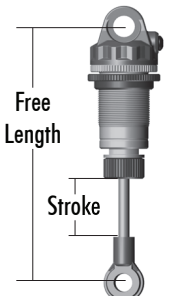

Track Info:

Size: Small Medium Large Extra Large

Surfaces: Dirt Carpet Astroturf Multi Surface

Traction: Low Medium High Very High

Moisture: Dry Damp Wet

Condition: Indoor Outdoor Dusty Hard Packed
Bumpy Grooved Smooth Loamy

Temperature: Ambient: 80 **Track:** 80

Notes:

Tires:

Tires (F/R): AKA Pinstripes / AKA Typos

Compound (F/R): Clay / Clay

Insert (F/R): AKA Evo / AKA Evo

Wheel (F/R): AKA Evo / AKA Evo

Notes:

Body & Wing:

Body: JConcepts Finisher

Wing: JConcepts High Clearance 6.5°

Wing Angle: 0° 3° 6°

Notes: Wing lip cut to 2 lines

Race Results:

Qualify: 2 **Main:** A

Finish: 2 **TQ:**

Best Lap Time: 19.5

Vehicle Comments:

#91551 Factory Team Bearing Set; #91545 Factory Team Graphite Battery Strap; #91446 & 91447 Factory Team Shock Bushings; #91547 Factory Team Milled Motor Plate;

Total Vehicle Weight: