

**Front Suspensions:**

**Camber:** -1

**Total Toe:** 0

**Ride Height:** 24.5mm

**Arm Type:** Flat, Standard Composite

**Tower Type:** Flat, Standard Composite

**Caster Block Insert:** 5

**Kick-Up Angle:** 25

**Notes:** Aluminum front pin brace; Plastic shock caps; Standard composite caster blocks and spindles

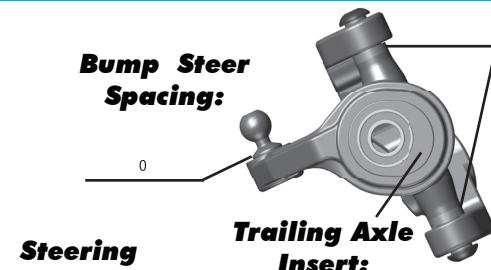

**Axle Height:**

Up

Middle

Down

**Ball Stud Spacing:** 2 mm

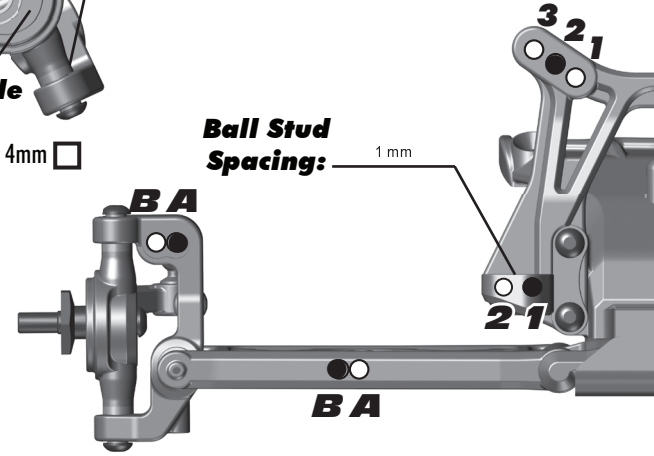
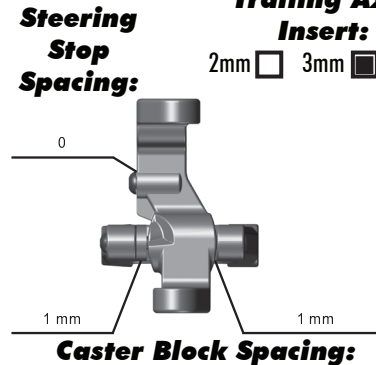

**Rear Suspension:**

**Camber:** -1

**Ride Height:** 24 mm

**Hub Spacing:** Forward  Middle  Back

**Notes:** Standard composite arms, hubs, tower & u-brace; Factory Team aluminum rear hubs (Front row, inside, 1 mm washers); Factory Team "C" & "D" Plate

**Anti Roll Bar:**

None

Black (1.2mm)

Silver (1.3mm)

Gold (1.4mm)

**Rear Hub Link Setting:**

**A** C B A Up  Down

**B** B A Up  Down

**Arm Mount:** 3

**Inboard Toe:** 2

**Anti-Squat:** 0°  0.5°  1°

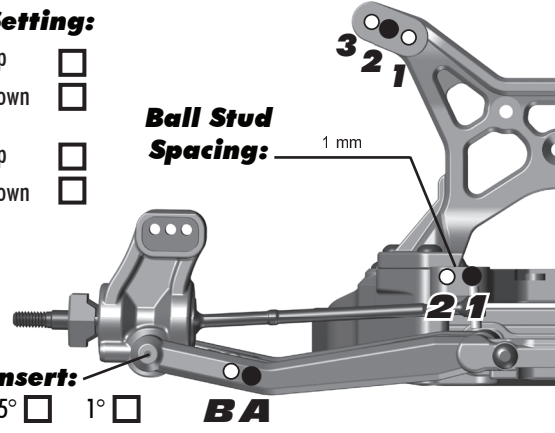

**Electronics:**

**Radio:** Airtronics M12 **Servo:** Sanwa 94661

**EPA: Throttle:** 97 % **Brake:** 82 %

**ESC:** Reedy Prototype (14 gauge wire)

**ESC Settings:** \_\_\_\_\_

**Motor:** Reedy Sonic Mach2

**Wind:** 8.0 **Timing:** 20

**Pinion:** 22 **Spur:** 78

**Battery:** Reedy SQ #314

**Battery Position:** Back

**Drivetrain:**

**Differential:**

Ball:

Setting: \_\_\_\_\_

Gear:

Oil: \_\_\_\_\_

**Slipper Clutch:**

**Type:** Associated

**# of Pads:** 2

**Notes:** \_\_\_\_\_

**Shocks:**

	Front	Rear
<b>Piston:</b>	2 x 1.6 Kit	2 x 1.6 Kit
<b>Oil:</b>	32	30
<b>Spring:</b>	Green	White
<b>Limiters:</b>	2	2
<b>Cup Offset:</b>	5 mm	5 mm
<b>Stroke:</b>	20 mm	26.5 mm
<b>Free Length:</b>	N/A	N/A
<b>Notes:</b>	#91493 Low Friction X-Rings	

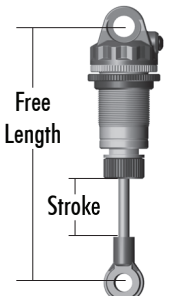

**Track Info:**

**Size:** Small  Medium  Large  Extra Large

**Surfaces:** Dirt  Carpet  Astroturf  Multi Surface

**Traction:** Low  Medium  High  Very High

**Moisture:** Dry  Damp  Wet

**Condition:** Indoor  Outdoor  Dusty  Hard Packed  Bumpy  Grooved  Smooth  Loamy

**Temperature: Ambient:** \_\_\_\_\_ **Track:** 50 F

**Notes:** \_\_\_\_\_

**Tires:**

**Tires (F/R):** JConcepts Dirt Webs / JConcepts Dirt Webs

**Compound (F/R):** Green / Green

**Insert (F/R):** AKA / AKA

**Wheel (F/R):** Associated Hex / Associated Hex

**Notes:** \_\_\_\_\_

**Body & Wing:**

**Body:** \_\_\_\_\_

**Wing:** \_\_\_\_\_

**Wing Angle:** 0°  3°  6°

**Notes:** \_\_\_\_\_

**Race Results:**

**Qualify:** \_\_\_\_\_ **Main:** \_\_\_\_\_

**Finish:** \_\_\_\_\_ **TQ:**

**Best Lap Time:** \_\_\_\_\_

**Vehicle Comments:**

\_\_\_\_\_

\_\_\_\_\_

**Total Vehicle Weight:** 1596g