

Front Suspensions:

Camber: 3 degree

Total Toe: 0 degree

Ride Height: 24mm

Arm Type: Flat; Standard Composite

Tower Type: Flat; Standard Composite

Caster Block Insert: 5

Kick-Up Angle: 25

Notes:

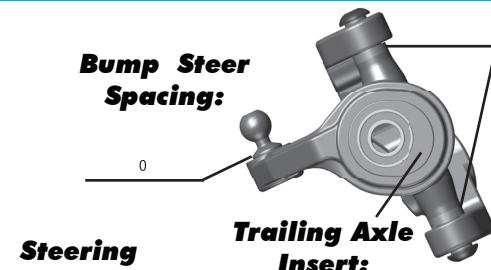

Axle Height:

Up

Middle

Down

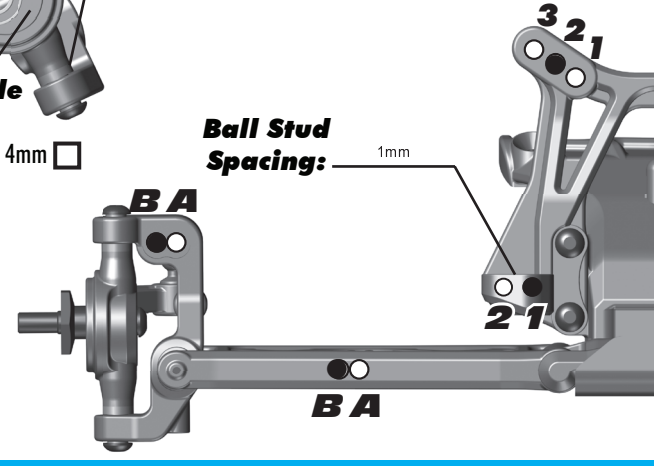
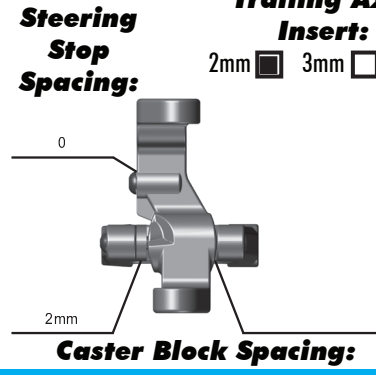
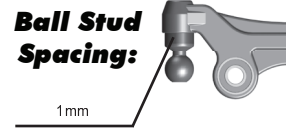

Rear Suspension:

Camber: 2

Ride Height: 24mm

Hub Spacing: Forward Middle Back

Notes:

Anti Roll Bar:

None

Black (1.2mm)

Silver (1.3mm)

Gold (1.4mm)

Rear Hub Link Setting:

A Up Down

B Up Down

Arm Mount:

Inboard Toe: 3

Anti-Squat: 2

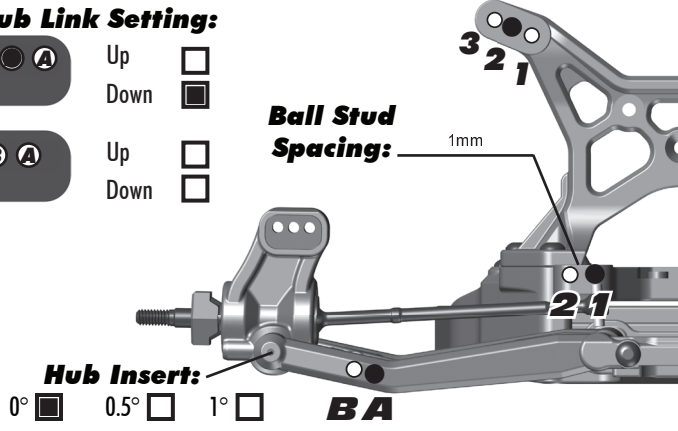

Electronics:

Radio: Airtronics M12 **Servo:** Sanwa

EPA: Throttle: 100 % **Brake:** 90 %

ESC: LRP Flow

ESC Settings:

Motor: Reedy Sonic Mach2

Wind: 7.5 **Timing:** 20

Pinion: 22 **Spur:** 81

Battery: Reedy SQ #314

Battery Position: Back

Drivetrain:

Differential:

Ball:

Setting: Medium Tight

Gear:

Oil:

Slipper Clutch:

Type: Associated

of Pads: 2

Notes: Tight

Shocks:

	Front	Rear
Piston:	2 x 1.6 Flat	2 x 1.6 Flat
Oil:	30wt	27.5wt
Spring:	Green	White
Limiters:	3	2
Cup Offset:	5mm	5mm
Stroke:	20.5 mm	26.5 mm
Free Length:		
Notes:		

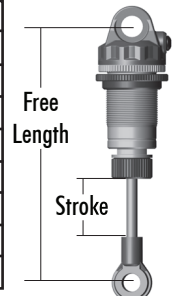

Track Info:

Size: Small Medium Large Extra Large

Surfaces: Dirt Carpet Astroturf Multi Surface

Traction: Low Medium High Very High

Moisture: Dry Damp Wet

Condition: Indoor Outdoor Dusty Hard Packed

Bumpy Grooved Smooth Loamy

Temperature: Ambient: 78 **Track:** 72

Notes:

Tires:

Tires (F/R): JConcepts Double Dees - 3002-02 cut to fronts / JConcepts - Double Dees - 3002-02

Compound (F/R): Green / Green

Insert (F/R): Stock - Open Cell / Stock - Open Cell

Wheel (F/R): JConcepts - 3347 White / JConcepts - 3348 White

Notes: Double Dees rear round 1, 3Ds rear and closed cell insert round 2, Double Dees rear main event

Body & Wing:

Body: #0272 - JConcepts Silencer

Wing: #0140 - Hi-Clearance wing

Wing Angle: 0° 3° 6°

Notes:

Race Results:

Qualify: 2nd **Main:** A

Finish: 2nd **TQ:**

Best Lap Time: 22.039

Vehicle Comments:

Very consistent performance all day long in changing conditions. Morning qualifiers were low traction and vehicle produced grip giving confidence. Traction increased considerably in round 2 dropping lap times substantially. B5 maintained balance, predictable weight transfer and jumped well in high speed situations.

Total Vehicle Weight: