



SETUP SHEET for the Team Associated RC10B4

Driver \_\_\_\_\_

Track / City \_\_\_\_\_

Event \_\_\_\_\_ Date \_\_\_\_\_

**FRONT**

**SHOCK MOUNTING & CAMBER LINK**

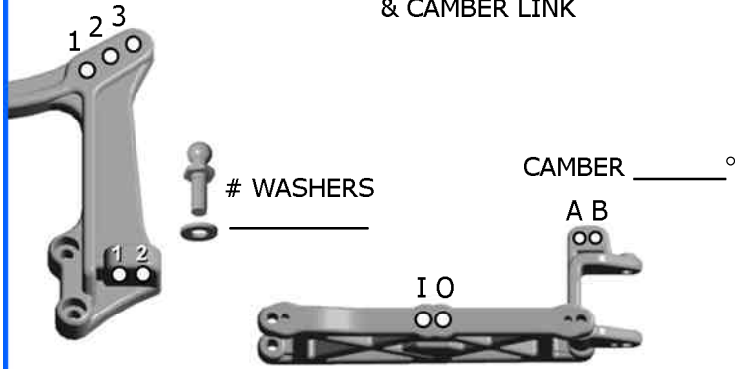

RIDE HEIGHT \_\_\_\_\_

TOE-IN (+)/OUT (-) \_\_\_\_\_°

BUMP STEER SPACER \_\_\_\_\_

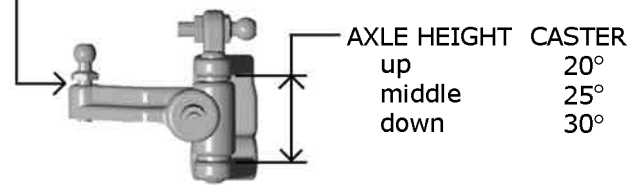

AXLE HEIGHT CASTER  
 up 20°  
 middle 25°  
 down 30°

STEERING BLOCK trailing inline

**REAR**

**SHOCK MOUNTING & CAMBER LINK**

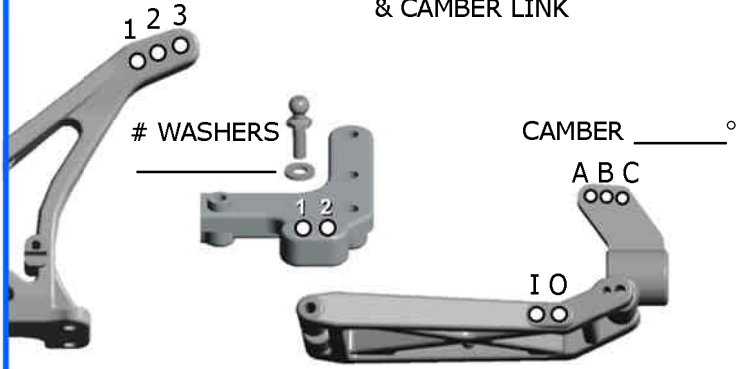

RIDE HEIGHT \_\_\_\_\_

ANTI-SQUAT

- 0°
- 1°
- 2°
- 3°

WHEELBASE  
 long  
 medium  
 short

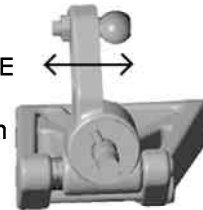

ANTI-ROLL BAR

- none
- black (soft)
- silver (med)
- gold (heavy)

**FRONT SHOCKS**

OIL \_\_\_\_\_ wt

SPRING (color) \_\_\_\_\_ PISTON # \_\_\_\_\_

SHAFT unobtanium STD # LIMITERS \_\_\_\_\_

**REAR SHOCKS**

OIL \_\_\_\_\_ wt

SPRING (color) \_\_\_\_\_ PISTON # \_\_\_\_\_

SHAFT unobtanium STD # LIMITERS \_\_\_\_\_

**FRONT TIRES & WHEELS**

FRONT TIRES \_\_\_\_\_

INSERTS \_\_\_\_\_ WHEELS \_\_\_\_\_

TRACTION COMPOUND \_\_\_\_\_

**REAR TIRES & WHEELS**

REAR TIRES \_\_\_\_\_

INSERTS \_\_\_\_\_ WHEELS \_\_\_\_\_

**RADIO/BATTERIES**

RADIO \_\_\_\_\_ SERVO \_\_\_\_\_

ESC \_\_\_\_\_

DRAG BRAKE \_\_\_\_\_ INIT BRAKE \_\_\_\_\_

BATTERY PLACEMENT front rear

BATTERIES \_\_\_\_\_

**MOTOR**

MOTOR & WIND \_\_\_\_\_

BRUSHES \_\_\_\_\_

SPRING \_\_\_\_\_

PINION / SPUR \_\_\_\_\_ / \_\_\_\_\_

**OTHER**

BODY \_\_\_\_\_

WING \_\_\_\_\_

WING ANGLE 0° 3° 6°

CHASSIS \_\_\_\_\_

**CONDITIONS**

- smooth
- bumpy
- low traction
- med traction
- high traction
- sandy
- soft dirt
- grass
- blue groove
- clay

- wet
- dry
- dusty
- other

**COMMENTS**

NOTES \_\_\_\_\_  
 \_\_\_\_\_  
 \_\_\_\_\_  
 \_\_\_\_\_