

SETUP SHEET for the Team Associated RC10B4

Driver Brent Thielke

Track / City OC/RC - Huntington Beach, CA

Event JConcepts Wave Date May 2009

FRONT SHOCK MOUNTING & CAMBER LINK

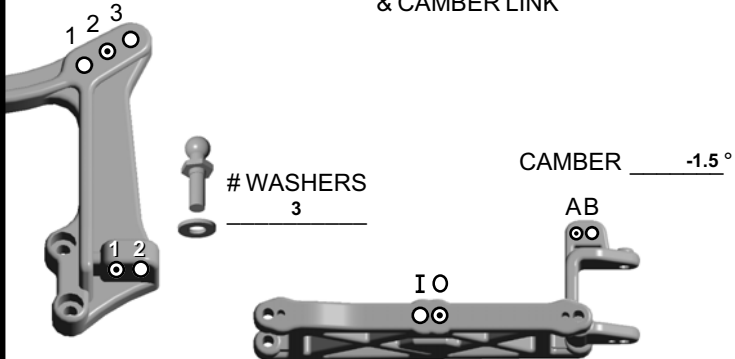

RIDE HEIGHT 24 mm

CAMBER -1.5°

TOE-IN (+) / OUT (-) 0°

BUMP STEER SPACER 2 mm

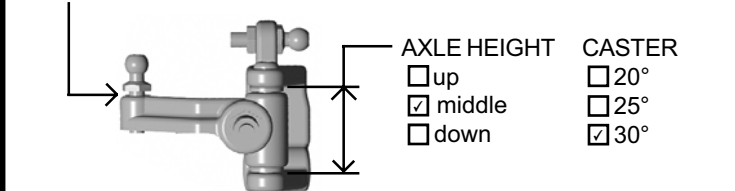

AXLE HEIGHT up middle down

CASTER 20° 25° 30°

STEERING BLOCK trailing inline

FRONT SHOCKS

OIL 30 wt

SPRING (color) Brown PISTON # 4 x #57

SHAFT unobtainium STD # LIMITERS -2

FRONT TIRES & WHEELS

FRONT TIRES JConcepts Gold Barcodes

INSERTS 2/3 JC And1 WHEELS Associated

TRACTION COMPOUND None

REAR SHOCK MOUNTING & CAMBER LINK

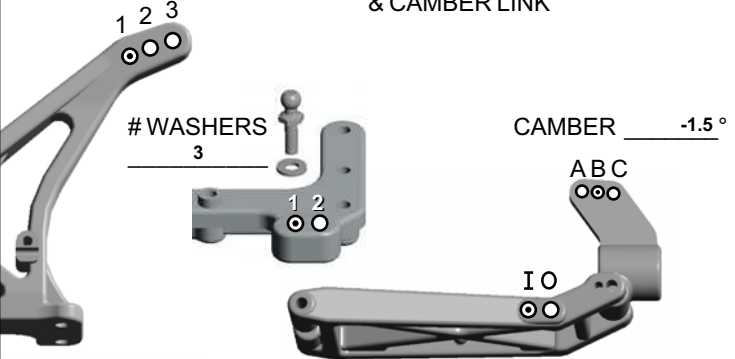

RIDE HEIGHT 24 mm

CAMBER -1.5°

ANTI-SQUAT 0° 1° 2° 3°

ANTI-ROLL BAR none black (soft) silver (med) gold (heavy)

WHEELBASE long medium short

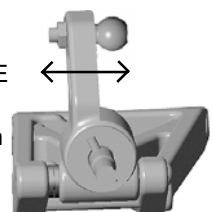

REAR SHOCKS

OIL 25 wt

SPRING (color) Green PISTON # 4 x #58

SHAFT unobtainium STD # LIMITERS 1

REAR TIRES & WHEELS

REAR TIRES JConcepts Gold Barcodes

INSERTS JC And1 WHEELS Associated

RADIO/BATTERIES

RADIO Airtronics M11 SERVO XP 1015

ESC LRP SXX (1/1/0/3)

DRAG BRAKE 3 INIT BRAKE 0

BATTERY PLACEMENT front rear

BATTERIES Reedy 20C 5000 (#703)

MOTOR

MOTOR & WIND LRP X-12 8.5 Turn (4 Dot Timing)

BRUSHES _____

SPRING _____

PINION / SPUR 24 / 78

OTHER

BODY JConcepts Scoopless Illuzion

WING Associated B44

WING ANGLE 0° 3° 6°

CHASSIS Plastic

CONDITIONS

smooth sandy

bumpy soft dirt

low traction grass

med traction blue groove

high traction clay

wet dusty

dry other

COMMENTS

CVDs; 1 oz weight in front of transmission;