

part #	description	qty	price
--------	-------------	-----	-------

part #	description	qty	price
--------	-------------	-----	-------

1:10 B3 OFF ROAD CATALOG

CATALOG #RC10B3 MAR 2001

Prices subject to change without notice. Typographic errors or other product pricing/description errors will not be honored. Parts subject to availability.

If you cannot obtain parts from your distributor or dealer, you may order them directly from us. (We're sorry, you cannot order car kits from us.)

ORDERING INSTRUCTIONS

1. Write out order on separate sheet of paper if order form is missing. Include part no., quantity, and price of each item. **Include your phone no., full name and return address. DO NOT SEND CASH. Credit card orders welcome.**
2. California residents add 7.5% sales tax.
3. Add shipping fee of \$5.00 to all orders except Red, Orange & Blue Label. Extra charge for faster Red, Orange & Blue Label services and international orders. Call for details.
4. All international orders must be prepaid by International Money Order in U.S. funds.
5. Mail order to: **Associated Electrics, Inc.**
3585 Cadillac Ave.
Costa Mesa, CA 92626 USA
6. Or call (714) 850-9342. **Please have your order ready before calling.**
7. Or fax (714) 850-1744. **Include your phone no., full name and return address.**

MORE RC10B3 PARTS!

The following FREE catalogs contain more parts and information for the B3 kits not listed in this catalog:

- **Factory Team catalog.** For high-performance hop-ups—graphite, titanium, lightweight aluminum, and more!
- **Reedy Modifieds catalog.** High-performance motors & batteries, and their accessories.
- **Pictorial catalog.** For full-color pictures of decals, T-shirts, caps, mousepad, and videos.
- <http://www.rc10.com>. Up-to-date online help.

RC10B3 KITS

9003	RC10B3 BASIC PLUS BUGGY KIT, Basic sport bushing kit with motor, but without the mechanical speed control. Less radio and batteries	1	215.00
9013	RC10B3 SPORT BUGGY KIT, with mechanical speed control, kit motor, bronze bushings, 2.40:1 Assoc. transmission, less radio and batteries	1	255.00
9021	RC10B3 WORLDS UPGRADE KIT. Upgrades your B3 to Worlds specs. Includes Pro-Line's Deja-Vu Tu body, low-profile rear shock tower, wide-body Pro-Line front and rear wheels.	1	29.95
9032	RC10B3 TEAM BUGGY KIT. Includes ball bearing Assoc. transmission, PTFE-coated shocks, Pro-Line tires, MIP CVD's, less radio and batteries.	1	299.95
9043	FACTORY TEAM B3. Includes Factory Team Blue and titanium parts, PTFE-coated shocks, ball bearing Assoc. transmission, Pro-Line tires, MIP CVD's, less radio and batteries.	1	369.95

BODY, WINGS & ACCESSORIES

6133	B2 BUGGY BODY, clear Lexan	1	14.00
6142	B3 BUGGY BODY, clear Lexan	1	14.00
6154	PRO-LINE DEJA-VU TU body & wing, clear Lexan	1	16.95
6180	DRIVER, clear	1	2.00
6181	HIGH DOWN FORCE WING KIT, includes #6182 wing, #6190 wing mounts and wire (used in current RC10 car kits)	1	3.50
6182	HIGH DOWN FORCE WING, 5 1/2"	1	2.00
6183	HIGH DOWN FORCE WING, 7"	1	2.00

6190	WING MOUNTS, adjustable (Wing-Things)	pr	1.75
6193	WING MOUNTS, ALUMINUM, fits .065" and .078" wire (#9454 & #9455 pre-bent wire)	pr	3.50
6193B	FACTORY TEAM BLUE WING MOUNTS, ALUMINUM, fits .065" and .078" wire (#9454 & #9455 pre-bent wire)	pr	4.50
9453	B2/B3 WING KIT, 6182 wing, mounts, and #9454 prebent wing wire (.065")	1	5.00
9454	WING WIRE, .065" prebent	1	2.50
9455	WING WIRE, .078":prebent	1	2.50

DECALS

For our current line of decals for your Lexan body, please see our full-color Pictorial Catalog.

FRONT SUSPENSION

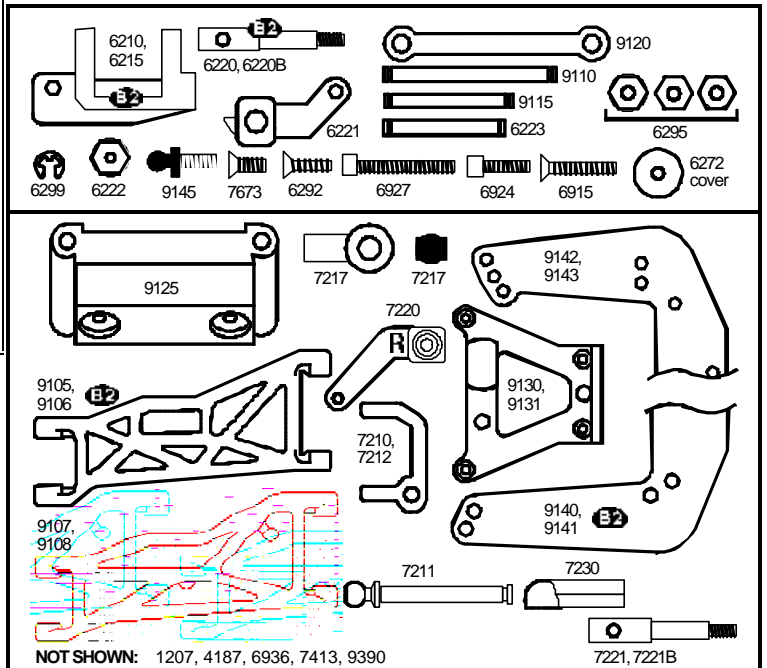

#9104 FRONT ANTI-ROLL BAR KIT



1207	FACTORY TEAM BLUE TITANIUM TURNBUCKLE KIT	set	27.00
4187	PLASTIC WASHER/SHIM, 1/32" thick spacer for 1/8" shafts	12	1.00
6210	B2 FRONT BLOCK CARRIER, 30° caster (Kit standard)	pr	3.00
6215	B2 FRONT BLOCK CARRIER, 25° caster	pr	4.50
6220	ALUMINUM FRONT INLINE AXLES. (Axle thread is 5-40.) Uses #6222 black nylon locknut	pr	6.00
6220B	FACTORY BLUE ALUMINUM FRONT INLINE AXLES. (Axle thread is 5-40.) Uses #6222 black nylon locknut	pr	7.50
6221	B2 INLINE STEERING BLOCK, for alum. axles	pr	2.00
6222	SELF-THREADING NYLON LOCKNUT, for #6220 axles	8	2.00
6223	KINGPIN, w/E-clips	2	2.50
6272	BALL END DUST COVER, foam	28	2.00
6292	4-40 X 3/8" FLAT HEAD Socket Screw	6	2.00
6295	NUT, 4-40, 6 each plain, lock, and nylon	18	2.00
6299	1/8" E-CLIPS	12	1.00
6915	4-40 X 5/8" FLAT HEAD Socket Screw	6	2.00
6924	4-40 X 3/8" SOCKET HEAD Cap Screw	6	2.00
6927	4-40 X 3/4" SOCKET HEAD Cap Screw	6	2.00
6936	#4 ALUMINUM WASHER	10	1.00
6951	4-40 X 1/8" SOCKET SET SCREW, with Allen wrench	6	2.50

part #	description	qty	price
7210	B3/T3 FRONT BLOCK CARRIER, 30 deg. caster	Pr	3.00
7211	B3/T3 KINGPIN BALL END	2	4.00
7212	B3/T3 FRONT BLOCK CARRIERS, 25 deg. caster	Pr	4.50
7217	B2/T2 SHOCK ROD END, nylon w/plastic pivot ball	2	3.00
7220	B3/T3 FRONT STEERING BLOCK	Pr	2.00
7221	B3/T3 FRONT AXLE, aluminum with #6222 nuts	2	6.00
7221B	FACTORY BLUE INLINE FRONT AXLE	pr	7.50
7230	B3/T3 PLASTIC BALL END CUPS, molded	12	5.00
7673	4-40 X 5/16" FLAT HEAD Socket Screw	6	2.00
8828	ROLL BAR CUP SET. Closed and open cup with 5/16" set screw	2pr	2.00
8830	ROLL BAR PIVOT, aluminum, with #6951 set screw	2	4.00
9103	B3/T3 FRONT ANTI-ROLL BAR WIRE, 2 sizes.	2	2.50
9104	B3/B2 FRONT ANTI-ROLL BAR KIT, light & heavy bars included in kit	pr	8.00
9105	B2 FRONT A-ARM, molded composite	pr	6.00
9106	B2 FRONT A-ARM, molded Carbon Fiber composite	pr	9.00
9107	B3 FRONT SUSPENSION ARMS, composite	Pr	6.00
9108	B3 FRONT SUSPENSION ARMS, molded Carbon Fiber composite	Pr	9.00
9110	B2 FRONT INNER HINGE PIN, special hardened tool steel	2	5.00
9115	B2/B3 FRONT OUTER HINGE PIN,	2	3.00
9120	B2/B3 FRONT CROSS BRACE, aluminum	1	1.50
9125	B2/B3 FRONT BULKHEAD, nylon	1	4.00
9130	B2/B3 FRONT TOP PLATE, molded composite	1	5.00
9131	B2/B3 FRONT TOP PLATE, molded Carbon Fiber composite	1	8.00
9140	B2 FRONT SHOCK STRUT, fiberglass	1	7.00
9141	B2 FRONT SHOCK STRUT, graphite	1	13.00
9142	B3 FRONT SHOCK STRUT, fiberglass	1	7.00
9143	B3 FRONT SHOCK STRUT, graphite	1	13.00
9145	BALL END, long thread (low profile) black, w/nuts and plastic cups (for front shock strut)	pr	3.00
9390	B3/T3 BALL BEARING SET	Set	45.00

FRONT END LINKAGE

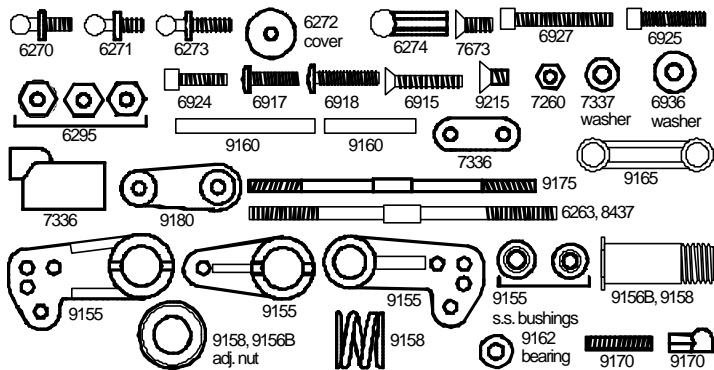

ALSO: 6295, 9150, 9162, 9215,

6270	SHORT BALL END, stainless steel, short thread, w/nuts & plastic ball cups	2	2.50
6271	SHORT BALL END, stainless steel, short thread, w/nuts & plastic ball cups	12	10.00
6272	BALL END DUST COVER, foam	28	2.00
6273	LONG BALL END, stainless steel, long thread (1/10" longer thread than #6270) w/nuts & plastic ball cups	2	2.50
6274	PLASTIC BALL CUPS, molded nylon (spares for #6270, #6271 or #6273)	14	5.00
6295	NUT, 4-40, 6 each plain, lock, and nylon	18	2.00
6915	4-40 X 5/8" FLAT HEAD Socket Screw	6	2.00
6917	4-40 X 3/8" BUTTON HEAD Socket Screw	6	2.00
6918	4-40 X 1/2" BUTTON HEAD Socket Screw	6	2.00
6924	4-40 X 3/8" SOCKET HEAD Cap Screw	6	2.00
6925	4-40 X 1/2" SOCKET HEAD Cap Screw	6	2.00
6927	4-40 X 3/4" SOCKET HEAD Cap Screw	6	2.00
6936	#4 ALUMINUM WASHER	10	1.00
7260	4-40 SMALL PATTERN PLAIN NUT	12	2.00

part #	description	qty	price
7336	STEERING SERVO MOUNT KIT, molded mounts, spacer, screws & washers	set	2.50
7337	SERVO MOUNT WASHERS, steel (gold colored)	4	1.00
7673	4-40 X 5/16" FLAT HEAD Socket Screw	6	2.00
8437	B2 TURNBUCKLE, for steering tie-rod	2	3.00
9150	B3/B2/T3 SERVO SAVER KIT, w/turnbuckles for steering tie-rods	1	11.00
9155	B3/B2/T3 SERVO SAVER, plastic parts only	1	3.50
9156B	B3/B2/T3 FACTORY BLUE SERVO SAVER HUB & COLLAR	1	6.50
9158	B3/B2/T3 NUT, TUBE & SERVO SAVER SPRING	1	4.50
9160	B3/B2/T3 SERVO SAVER & BELLCRANK PINS	2	3.00
9162	B3/B2/T3 OPTIONAL STEERING BELLCRANK BEARINGS, 1/8" X 1/4" flanged ball bearing. (replaces bushings in right side steering bellcrank)	2	15.00
9165	B3/B2/T3 STEERING DRAG LINK, molded nylon	1	2.00
9170	B3/B2/T3 ADJUSTABLE SERVO LINK, 4-40 X 1/2" set screw with special plastic ball cups	1	2.00
9175	B2 TURNBUCKLE, for front camber link	2	3.00
9180	SERVO HORNS, molded (1 ea. fits Airtronics, Futaba, Hitec, or JRpropo)	1	2.50
9215	6-32 X 3/16" FLAT HEAD Machine Screw, phillips	6	1.50

CHASSIS PARTS

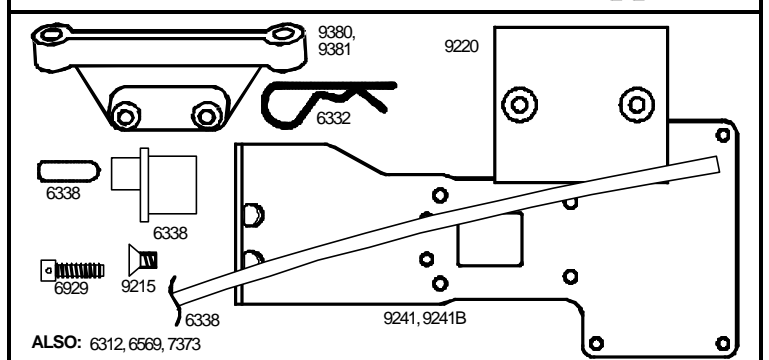
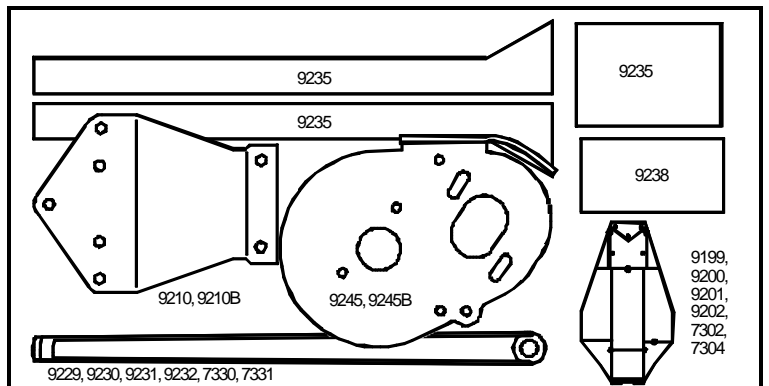

ALSO: 6312, 6569, 7373

6312	CLEAR CHASSIS PROTECTIVE SHEET to protect the chassis finish, 6 1/2" X 18"	1	6.50
6332	HOOD PIN	6	.75
6338	ANTENNA KIT, with hardware	1	2.00
6569	MOTOR PLATE SPACERS & END CAP	Set	1.50
6929	SOCKET HEAD Cap Screw, 4-40 X 3/8" with hole	4	2.00
7302	B3/B2/T3 CHASSIS, LONG, molded Carbon Fiber composite (standard chassis length for T3)	1	25.00
7304	B3/B2/T3 CHASSIS, LONG, molded Carbon Fiber composite (standard chassis length for T3)	1	45.00
7330	BATTERY HOLD DOWN STRAP, LONG, molded composite	1	3.00
7331	BATTERY HOLD DOWN STRAP, LONG, molded Carbon Fiber composite	1	5.00
7373	MOTOR PLATE GASKET	1	1.50
9199	B3/B2 CHASSIS, STANDARD, molded Carbon Fiber composite	1	45.00
9200	B3/B2 CHASSIS, STANDARD, molded composite	1	25.00
9201	B3/B2 CHASSIS, SHORT, molded composite	1	25.00

part #	description	qty	price
9202	B3/B2 CHASSIS, SHORT, molded Carbon Fiber composite	1	45.00
9210	B3/B2/T2 FRONT KICKUP (nose plate), aluminum, black hard anodized	1	7.50
9210B	B3/B2/T2 FACTORY BLUE FRONT KICKUP (nose plate), aluminum, blue anodized	1	10.00
9215	6-32 X 3/16" FLAT HEAD MACHINE SCREWS, Phillips (for mounting front kickup to chassis)	6	1.50
9220	FRONT BUMPER, molded nylon	1	2.50
9229	BATTERY HOLD DOWN STRAP, STANDARD, molded Carbon Fiber Composite	1	5.00
9230	BATTERY HOLD DOWN STRAP, STANDARD, molded composite	1	3.00
9231	BATTERY HOLD DOWN STRAP, SHORT, molded composite	1	3.00
9232	BATTERY HOLD DOWN STRAP, SHORT, molded Carbon Fiber composite	1	5.00
9235	BATTERY PADS, 3 adhesive foam pads for sides and bottom rear of battery slot	1	3.00
9238	BATTERY SPACERS, foam pads for spacing battery weight	2	2.00
9241	B3/B2/T3 REAR CHASSIS PLATE, aluminum, black hard anodized	1	9.00
9241B	FACTORY BLUE REAR CHASSIS PLATE	1	12.00
9245	B3/B2/T3 MOTOR MOUNT, aluminum, black anodized	1	6.00
9245B	B3/B2/T3 FACTORY BLUE MOTOR MOUNT, aluminum, blue anodized	1	8.00
9380	B2 TRANSMISSION BRACE, molded composite	1	4.00
9381	B2 TRANSMISSION BRACE, molded Carbon Fiber composite	1	6.00

REAR SUSPENSION

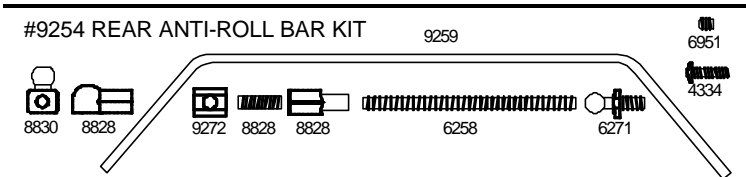
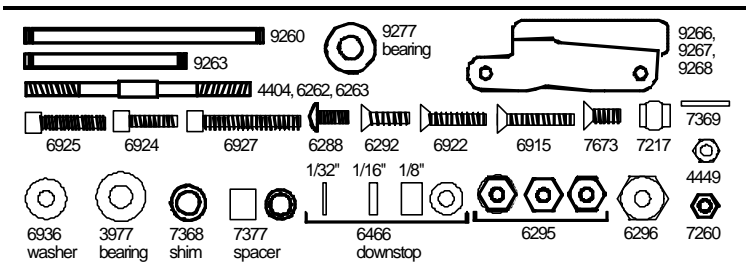
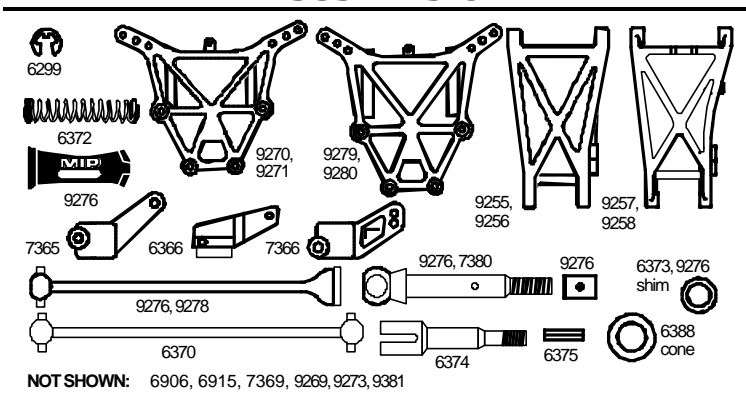

Toe-in degrees refer to one side of vehicle

3977	3/16 x 3/8 BALL BEARING	pr	6.00
4334	2-56 X 5/16" BUTTON HEAD socket screw	8	1.50
4404	TURNBUCKLE, for rear camber link	2	3.00
4449	4-40 ALUM. LOCKNUT, small pattern (gold anodized)	5	2.50
6288	4-40 X 1/4" BUTTON HEAD Socket Screw	6	2.00
6258	THREADED RODpr	2.00	

part #	description	qty	price
6262	B3 TURNBUCKLE, 1.65"	2	3.00
6263	B3 TURNBUCKLE, 2.06"	2	3.00
6271	SHORT BALL END, with nuts and plastic ball cups	12	10.00
6292	4-40 X 3/8" FLAT HEAD Socket Screw	6	2.00
6295	NUT, 4-40, 6 each plain, lock, and nylon	18	2.00
6296	8-32 LOCKNUTS, 6 each alum. and nylon	12	3.00
6299	1/8" E-CLIPS	12	1.00
6366	REAR HUB CARRIER, 1.5° toe-in (per side). Requires special 3/16" X 3/8" flanged bearing #9277 (only fits #9275 or #7367 rear axles)	pr	4.50
6370	DOG BONE (rear half shaft) for all basic and sport buggies	1	6.00
6372	DOG BONE SPRING and spacers	4	.75
6373	1/4" REAR AXLE SHIMS/SPACERS .010" thick for all 1/4" axles	14	1.50
6374	REAR STUB AXLE 1/4" dia., with roll pin (fits only #7359 bearing aor #7360 bushing)	1	5.00
6375	ROLL PIN for stub axle (only fits #6374 axle)	6	.75
6388	CONE WASHER, 1/4" x .400" .006"	4	1.00
6466	SHOCK DOWNSTOPS, (travel limiters), 4 ea. of 3 sizes 1/8" (.125"), 1/16" (.062") and 1/32" (.031")	set	1.50
6915	4-40 X 5/8" FLAT HEAD Socket Screw	6	2.00
6922	4-40 X 1/2" FLAT HEAD Socket Screw	6	2.00
6924	4-40 X 3/8" SOCKET HEAD Cap Screw	6	2.00
6925	4-40 X 1/2" SOCKET HEAD Cap Screw	6	2.00
6927	4-40 X 3/4" SOCKET HEAD Cap Screw	6	2.00
6936	#4 ALUMINUM WASHER	10	1.00
6951	4-40 X 1/8" SOCKET SET SCREW with Allen Wrench	6	2.50
7217	SHOCK ROD END, nylon w/plastic pivot ball	2	3.00
7260	4-40 SMALL PATTERN PLAIN NUT	12	2.00
7365	REAR HUB CARRIER, 0° toe-in per side (uses unflanged bearings) NOT FOR B3 OR T3.	pr	3.50
7366	B3/T3 REAR HUB CARRIER, 3° toe-in, molded composite	pr	3.50
7368	UNIVERSAL SHIMS, fits #9275 or #7367 rear axles	14	1.50
7369	B2/T2 AXLE SPRING PINS, fits #9275 or #7367 axles	4	1.00
7377	REAR AXLE BEARING SPACER, aluminum (fits 3/16" rear axle)	2	1.50
7673	4-40 X 5/16" FLAT HEAD Socket Screw	6	2.00
7380	CVD 3/16" AXLE	1	8.00
7381	CVD REBUILD KIT for two axles	Set	8.50
8828	ROLL BAR CUP SET. Closed and open cup with 5/16" set screw	2pr	2.00
8830	ROLL BAR PIVOT, aluminum, with #6951 set screw	2	4.00
9254	B3/T3 REAR ANTI-ROLL BAR KIT, light & heavy bars included in kit	1	8.00
9255	B2 REAR A-ARMS, molded composite	pr	7.00
9256	B2 REAR A-ARMS, molded Carbon Fiber composite	pr	10.00
9257	B3 REAR A-ARMS, composite	pr	7.00
9258	B3 REAR A-ARMS, Carbon Fiber composite	pr	10.00
9259	REAR ANTI-ROLL BAR KIT, with light & heavy bars	2	2.50
9260	B3/B2/T3 REAR INNER HINGE PIN, with E-clips	pr	3.00
9263	B3/B2/T3 REAR OUTER HINGE PIN, with E-clips	pr	2.50
9266	B3/B2/T3 REAR SUSPENSION MOUNTS, 2° toe-in (per side)	pr	2.00
9267	B3/B2/T3 REAR SUSPENSION MOUNTS, 3° toe-in (per side) and 3° anti-squat	pr	2.00
9268	B3/B2/T3 REAR SUSPENSION MOUNTS, 3° toe-in (per side) and 0° anti-squat	pr	2.00
9269	5-40 X 1/2" FHSScrew	6	2.00
9270	B2 REAR SHOCK STRUT, molded composite	1	5.00
9271	B2 REAR SHOCK STRUT, molded Carbon Fiber composite	1	7.50
9272	REAR ANTI-ROLL BAR MOUNTS AND SCREWS, 2-56 x 5/16" button head socket screw	Set	2.00
9273	DOG BONE SPACER, ith spring. Replacement spacers & springs for all Sport and Basic kits.	2	1.00
9276	B3/B2 MIP CVD's, rebuildable universal axles. Will also fit RC10 series with #9277 bearings.	Pr	35.50

part #	description	qty	price
6745	WIRE HARNESS, motor output, with one .1ufd. capacitor installed	1	3.00
6746	ADAPTER, Tamiya 2 pin JST battery connector with old RC10 3 pin AMP connector	1	4.00
6747	WIRE HARNESS, input, 2 pin JST Tamiya plug with JST BEC connector	1	3.00
7527	SERVO MOUNTS for throttle servo & steering servo	1	2.50
7709	NYLON WIRE TIE, 4" light duty	12	1.25
8850	RESISTON BRACKET, aluminu,, black anodized	Set	7.00

part #	description	qty	price
SP-41	B3 '97 WORLDS T-SHIRT. Printed front and back in full color on 100% cotton. Specify M, L, XL only.	1	13.00*
SP-41XXL	B3 '97 WORLDS T-SHIRT. Printed front and back in full color on 100% cotton. Size XXL.	1	15.00*
SP-410	TEAM ASSOCIATED JACKET, red,white & blue. Fully lined. Specify M,L,XL, XXL, XXXL	1	59.95**

SPEED CONTROLS, RECEIVER & CHARGER

Please contact Associated for it's current recommended LRP digital speed controls and chargers.

MISCELLANEOUS ITEMS

6194	COMPLETE TUNING GUIDE: B3. More than 70 illustrations detailing over 40 tuning options to set up your buggy to WIN!	1	3.95
------	---------------------------------------------------------------------------------------------------------------------	---	------

FASTENERS

6939	4-40 X 1/4" ALUM. FLAT HEAD Socket Screw	6	2.00
6933	4-40 X 5/16" ALUM. FLAT HEAD Socket Screw	6	2.00
6934	4-40 X 3/8" ALUM. FLAT HEAD Socket Screw	6	2.00
7873	4-40 X 7/16" ALUM. FLAT HEAD Socket Screw	8	2.50
6938	4-40 X 1/2" ALUM. FLAT HEAD Socket Screw	6	2.00
7658	8-32 X 3/8" ALUM. FLAT HEAD Machine Screw	6	2.00
6280	8-32 X 1/2" ALUM. FLAT HEAD Machine Screw	16	2.00
6281	8-32 X 7/8" ALUM. FLAT HEAD Machine Screw	6	2.00
3325	8-32 X 1 1/4" ALUM. FLAT HEAD Machine Screw	6	1.50
6284	4-40 X 1/4" ALUM. SOCKET HEAD Cap Screw	12	4.00
4145	4-40 X 5/16" ALUM. SOCKET HEAD Cap Screw	4	1.50
6860	4-40 X 3/8" ALUM. SOCKET HEAD Cap Screw	6	2.50
7801	4-40 X 5/8" ALUM. SOCKET HEAD Cap Screw	8	2.50
6935	4-40 X 1" ALUM. SOCKET HEAD Cap Screw	4	3.00
6936	#4 ALUMINUM FLAT WASHER	10	1.00
3323	#8 ALUMINUM FLAT WASHER, thick	12	1.50
3438	8-32 ALUMINUM LOCKNUT	3	1.50
4449	4-40 ALUM. LOCKNUT, small pattern (gold anodized)	5	2.50
6222	4-40/5-40 NYLON SELF THREADING LOCKNUTS, black	8	2.00
6937	4-40 ALUMINUM LOCKNUTS (blue anodized)	6	3.00

TOOLS

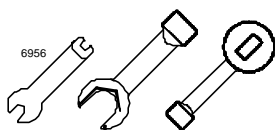

See the Factory Team catalog for our complete line of aluminum hex handle, color-coded Allen Drivers.

6956	ASSOCIATED MOLDED TOOL SET	set	4.50
6950	ALLEN WRENCH SET, .050", 1/16", 5/64", 3/32"	set	2.50

EQUIPMENT CARRIERS

See our Pictorial Catalog for full-color pictures of car carrier, shirts and videos

SP-100	ASSOCIATED CAR CARRIER BOX, cardboard outer box w/locking end flap (fits inside #SP-415 carrier bag), includes three 24" X 12" X 6" inner boxes. Due to its large size, an additional \$15.00 must be added to UPS standard shipping charges	1	15.00**
SP-101	INNER BOXES 24" X 12" X 6." Replacement carboard inner boxes for #SP-100 car carrier box	3	5.25**
SP-415	ASSOCIATED CAR CARRIER BAG, black nylon w/brass zipper. Fits #SP-100 car carrier box	1	39.95**

APPAREL

See our Pictorial Catalog for a full listing of all apparel.