

1:10 SCALE ELECTRIC
COMPETITION
OFF-ROAD CAR KIT

REQUIRES AND ACCEPTS ALL
POPULAR 2 CHANNEL RADIO SYSTEMS
RADIO AND ELECTRONIC SPEED
CONTROL NOT INCLUDED

RB10 RETRO

1:10 OFF ROAD RACING
EDITION



TEAM ASSOCIATED

1:10 Scale 2WD Electric Off Road Competition Buggy Kit Manual

#90054 RB10 Retro Kit



CHAMPIONS *by* DESIGN

AssociatedElectrics.com

TEAM ASSOCIATED

:: Introduction

Thank you for purchasing this Team Associated product. This assembly manual contains instructions and tips for building and maintaining your new RTR. Please take a moment to read through this manual to help familiarize yourself with these steps. We are continually changing and improving our designs; therefore, actual parts may appear slightly different than in the illustrations. New parts will be noted on supplementary sheets.

:: KIT Features

- New Retro Blue aluminum B5 tub chassis (rear motor)
- New Retro Blue aluminum front nose plate
- New front and rear molded bulkhead parts
- Exclusive grey plastics throughout
- High downforce 5.5" retro wing included
- 12mm Hex Dish Wheels
- Authentic retro Viper body included
- High Grip Offroad tires included
- Aluminum Blue anodized 12mm big bore coil-over shock absorbers
- B5 Rear motor stealth transmission
- Rear CVA driveshafts for more durability
- 2.6:1 ratio gearbox with heavy-duty sealed gear differential
- Adjustable V2 slipper system
- Rugged steel turnbuckles for adjustable camber and front toe-in
- Fully adjustable suspension geometry
- Vertical ball ends for roll center adjustments, front and rear
- Metric hardware throughout
- Full ball bearings included

:: Additional

Your new kit comes unassembled and requires the following items for completion (refer to www.AssociatedElectrics.com and www.Reedypower.com for suggestions):

- R/C two channel surface frequency radio system
- AA-size batteries for transmitter
- Electronic Speed Control ("ESC")
- Steering servo
- R/C electric motor (540 size)
- Pinion gear (48P), size determined by type/turn or kV of motor
- Battery charger (a peak detection charger, or LiPo compatible charger)
- 2 cell LiPo battery pack
- Polycarbonate specific spray paint
- Cyanoacrylate glue ("CA") (#1697)
- Thread locking compound (#1596)
- Tires and Inserts, Fronts and Rears
- Wheels w/12mm Hex
 - Front Wheels #9690 (white), #9691 (yellow)
 - Rear Wheels #9695 (white), #9696 (yellow)
- Slim Front Wheels w/12mm Hex (carpet/astro turf) #91757 (white) #91758 (yellow)

:: Other Helpful Items

- Silicone Shock Fluid (Refer to AssociatedElectrics.com for complete listings)
- Green Slime shock lube (#1105)
- FT Hex/Nut Wrenches (#1519, 1650)
- FT Universal Tire Balancer (#1498)
- Ride Height Gauge
- FT Body Reamer (#1499)
- FT Ballcup Wrench (#1579)
- Calipers or a Precision Ruler
- Shock Pliers (#1681)
- Hobby Knife
- FT Body Scissors (#1737)
- Wire Cutters
- Needle Nose Pliers
- Soldering Iron















Associated Electrics, Inc.
 21062 Bake Parkway
 Lake Forest, CA 92630





Customer Service
 Tel: 949.544.7500
 Fax: 949.544.7501

:: Hardware - 1:1 Scale View









Button Head (bhcs)

	2x3mm (31509)
	2x4mm (31510)
	2.5x8mm (31521)
	2.5x10mm (31522)
	3x5mm (31530)
	3x8mm (31532)
	3x10mm (25211)
	3x12mm (89202)
	3x14mm (25187)
	3x16mm (89203)
	3x22mm (25189)
	3x24mm (89204)
	3x26mm (89205)
	3x30mm (91478)

Cap Head (shcs)

	2.5x14mm (71032)
	3x24mm (89225)
	3x45mm (89279)

Flat Head (fhcs)

	2.5x10mm (31350)
	3x6mm (31541)
	3x8mm (25201)
	3x10mm (25202)
	3x12mm (25203)
	3x14mm (89208)
	3x16mm (25204)
	3x20mm (89210)





Set Screws

	3x3mm (25225)
---	----------------------





Clips

	E-clip 1/8 (6299)
---	--------------------------

Shims and Washers

	Servo Mount Washer (7337) (.250 x .125 x .815)
	FT Ballstud Washer, Aluminum (0.5mm) (31381)
	FT Ballstud Washer, Aluminum (1mm) (31382)
	FT Ballstud Washer, Aluminum (2mm) (31383)
	3x8mm Washer (89218)





Ball Bearings

	3x7x3mm (91475)
	5x10x4mm (25237)
	6x13x5 (91562)
	10x15x4 (91563)

Ballstuds

	HD 6mm (91047) Titanium HD 6mm (91751)
	HD 8mm (91048) Titanium HD 8mm (91752)
	HD 10mm (91049) Titanium HD 10mm (91753)

Nuts (lock/plain)

	M2.5 Locknut, Shock Piston (89215)
	M3 Nut (91477)
	M3 Alum. Locknut, Blue (31550)
	M3 Locknut, Black (25215)
	M3 Locknut w/Flange (25612)
	FT 3mm Locknuts, Blue(25392)
	M4 Serrated w/Flange (91738)
	FT M4 Locknuts w/Flange, Blue (31551)
	M4 LP Serrated Nut (92254)

Notes:

:: Table of Contents

1.....	Cover	11.....	Front Caster / Rear Hub and Turnbuckles Build
2.....	Introduction	13.....	Shocks Build
3.....	1:1 Hardware "Fold Out"	15.....	Electronics Build
4.....	Table of Contents	16.....	Wing Mount Build
5.....	Front Top Plate and Steering Build	17.....	Body and Wing Build
6.....	Suspension Build	17.....	Wheels and Tires Build
7.....	Gear Differential Build	18.....	Tuning Tips
8.....	Gearbox Build	20.....	Notes
10.....	Shock Towers Build	22.....	Back Cover

:: Notes



This symbol indicates a special note or instruction in the manual.



This symbol indicates a Racers Tip.



There is a 1:1 hardware foldout page in the front of the manual. To check the size of a part, line up your hardware with the correct drawing until you find the exact size. Each part in the foldout has a number assigned to it for ordering replacement parts.

**Associated Electrics, Inc.
21062 Bake Parkway.
Lake Forest, CA 92630**



**Customer Service
Tel: 949.544.7500
Fax: 949.544.7501**

:: Front Top Plate and Steering Build - Bag 1 - Step 1

91047 $\Sigma 2$
Heavy-duty Ballstud, 6mm

91475 $\Sigma 4$
3 x 7 x 3 Ball Bearing

91246
Steering Rack, Gray

91391 $\Sigma 2$
Steering Rack Crush Tube

91246
Steering Bellcrank Right, Gray

91246
Steering Bellcrank Left, Gray

89202 $\Sigma 2$
M3 x 12mm BHCS

91047
Heavy-duty Ballstud, 6mm

Note orientation of steering rack.

Do not over-tighten steering bolts. Make sure there is free movement in the steering rack.

:: Front Top Plate and Steering Build - Bag 1 - Step 2

Note orientation of the brace.

91475 $\Sigma 4$
3 x 7 x 3 Ball Bearing

91246
Steering Bellcrank Brace, Gray

25189 $\Sigma 2$
M3 x 22mm BHCS

91247
Front Top Plate, Gray

:: Front Top Plate and Steering Build - Bag 1 - Step 3

91233
Front Mount

91232 $\Sigma 2$
Front Mount Stud

91231
Nose Plate, Blue

91230
RB10 Retro Chassis, Blue

25202 $\Sigma 2$
M3 x 10mm FHCS

91240
Bulkhead, Gray

31540
M3 x 5mm FHCS

89208 $\Sigma 2$
M3 x 14mm FHCS

89210 $\Sigma 2$
M3 x 20mm FHCS

:: Gear Diff Build - Bag 3 - Step 1

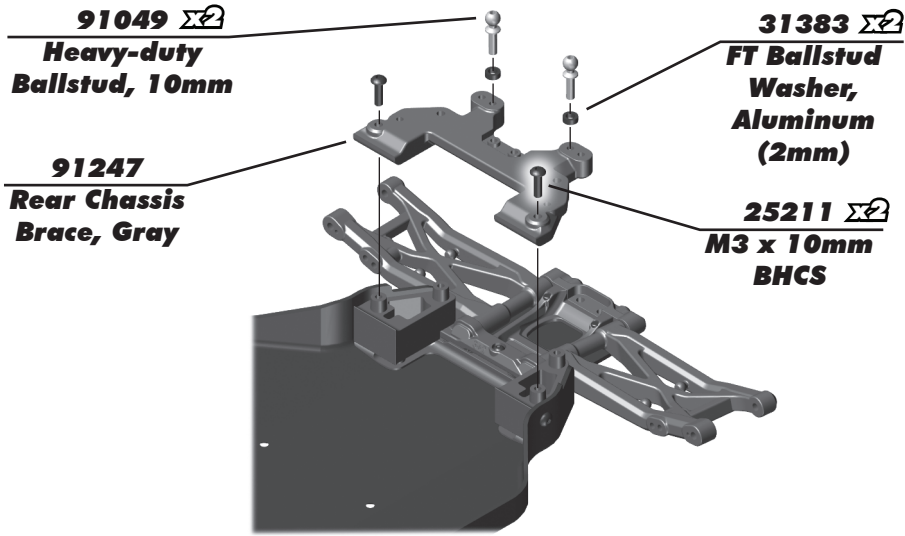

:: Gear Diff Build - Bag 3 - Step 2

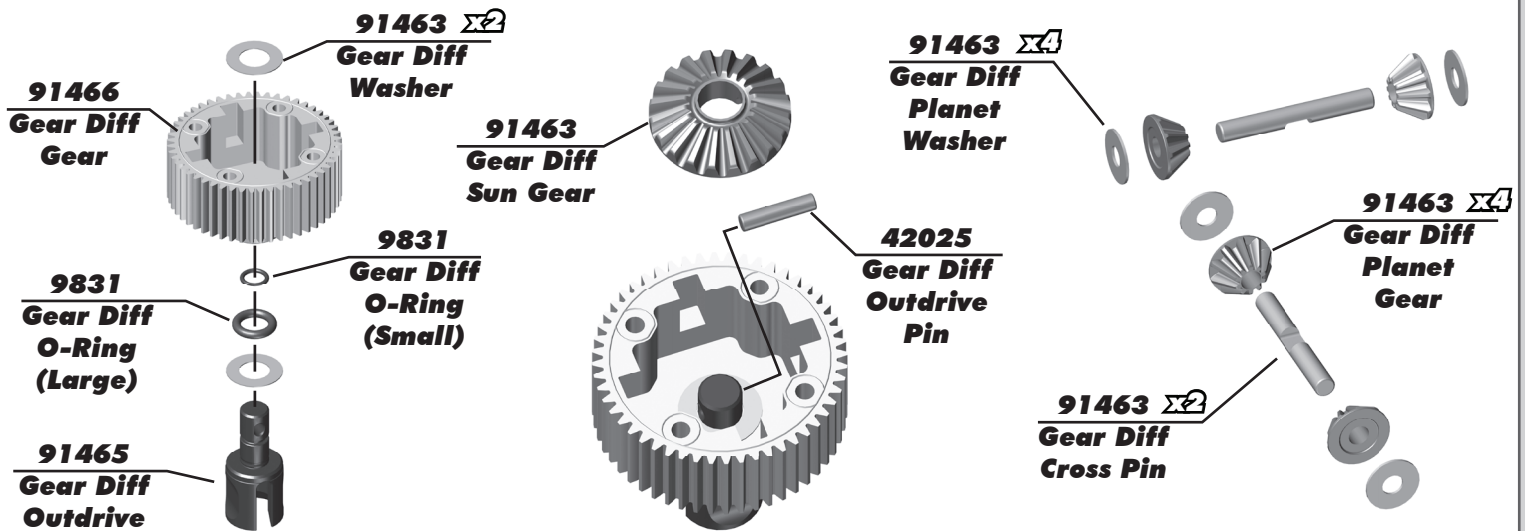

:: Gear Diff Build - Bag 3 - Step 3

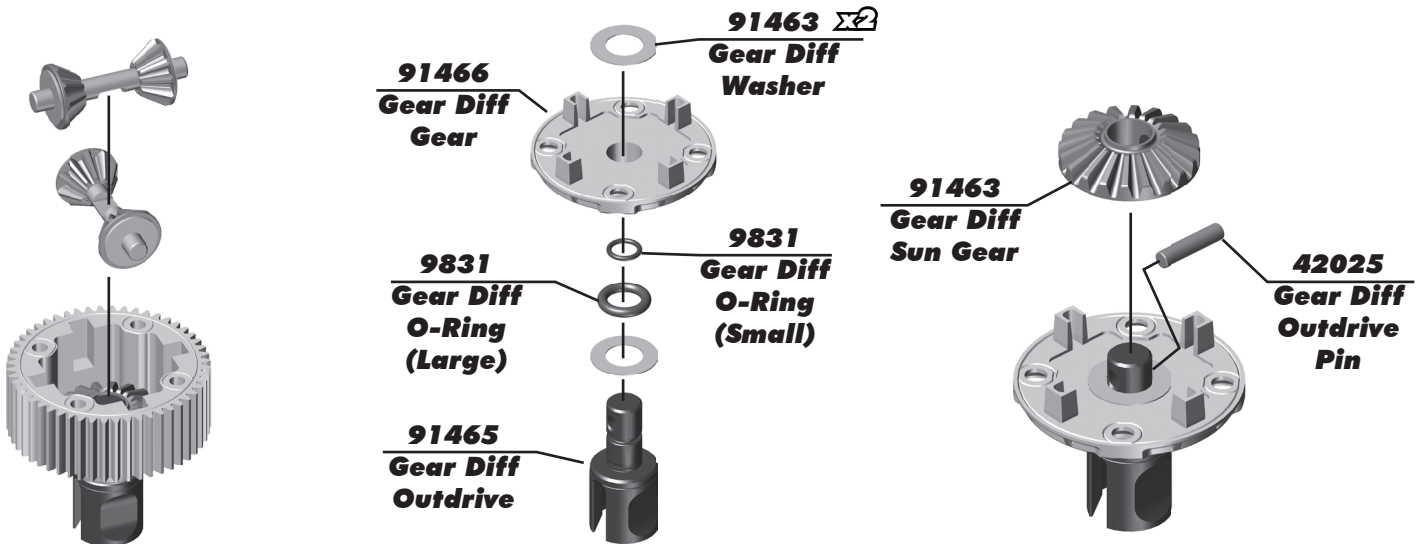

:: Gear Diff Build - Bag 3 - Step 4

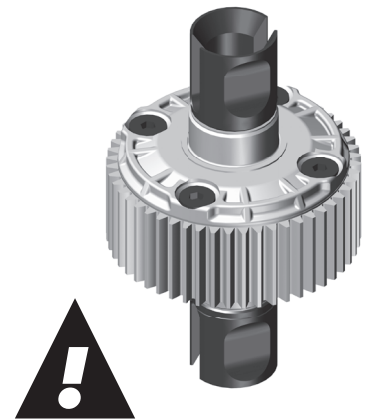
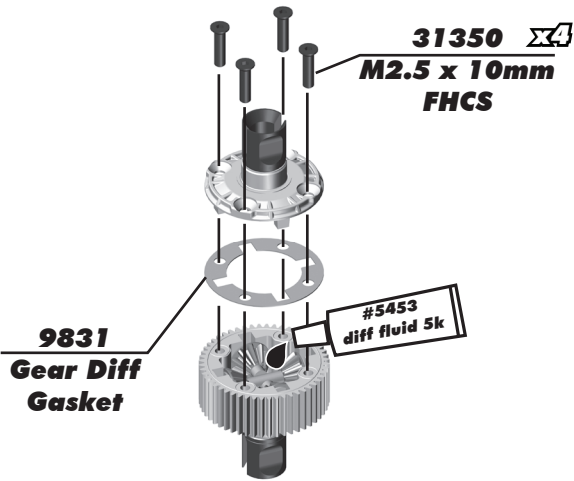

* Ensure free outdrive rotation before installation!

:: Gearbox Build - Bag 3 - Step 5

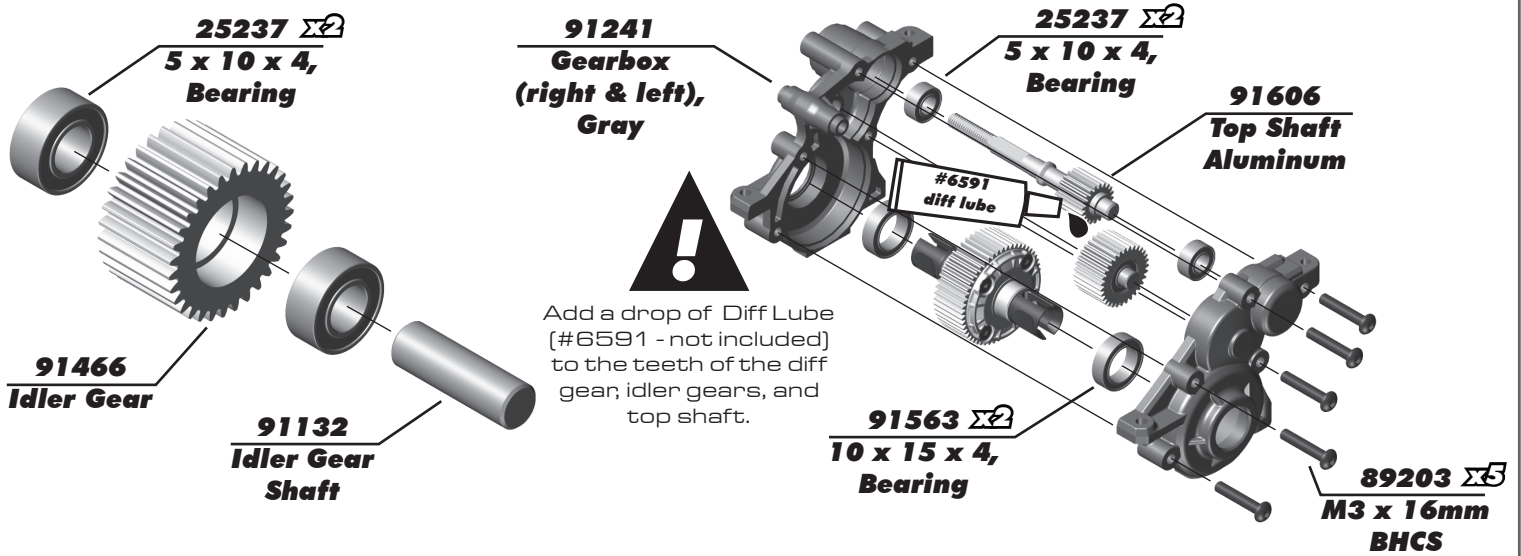

:: Gearbox Build - Bag 3 - Step 6

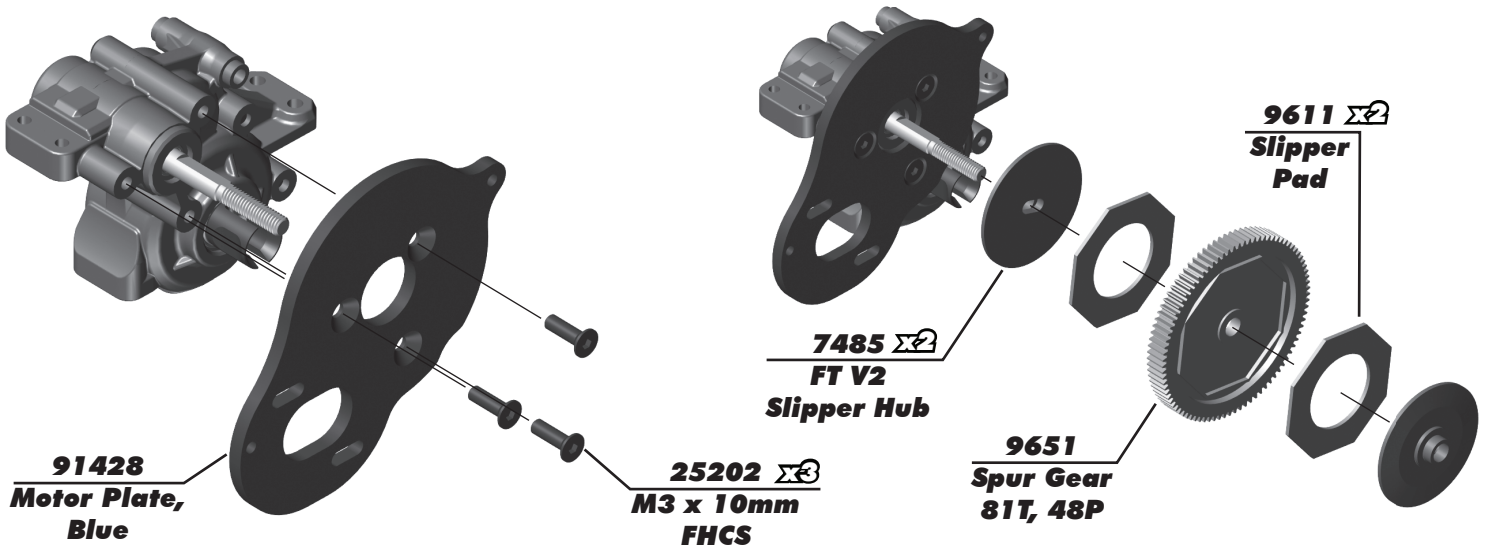

:: Gearbox Build - Bag 3 - Step 7

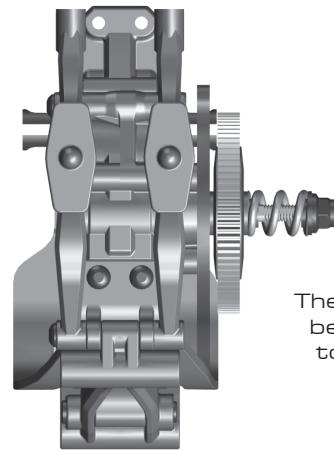
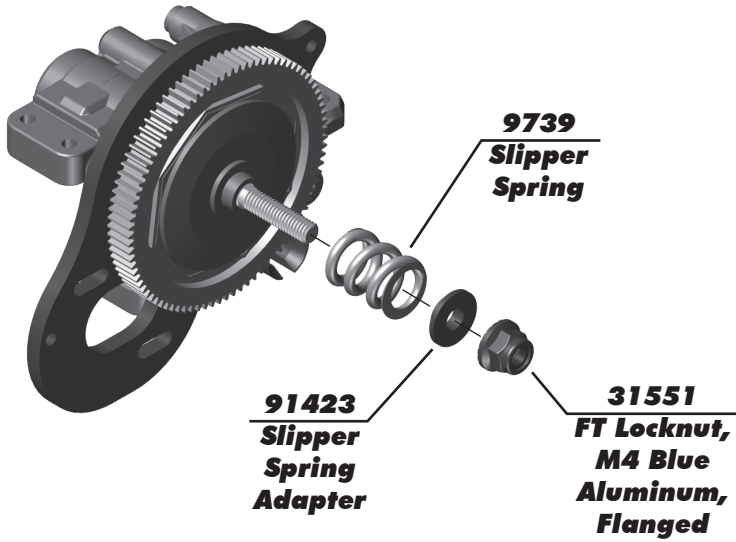

The locknut should be flush with the top shaft when installed.

:: Gearbox Build - Bag 3 - Step 8

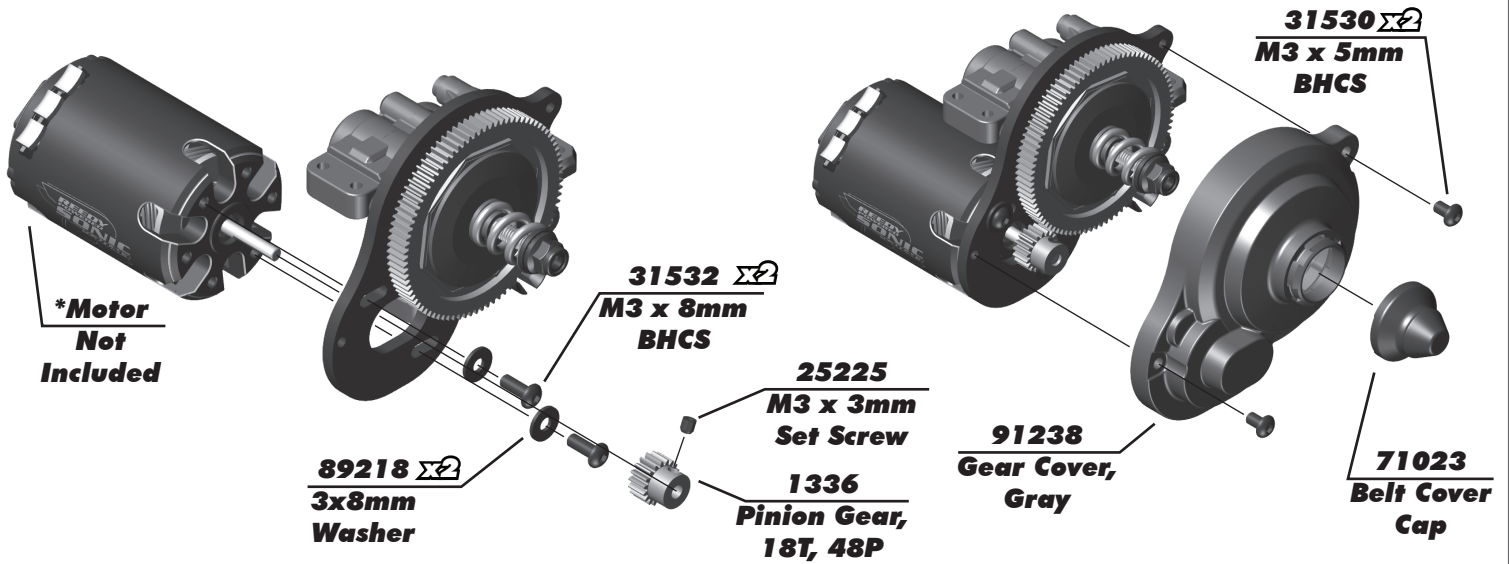

:: Gearbox Build - Bag 3 - Step 9

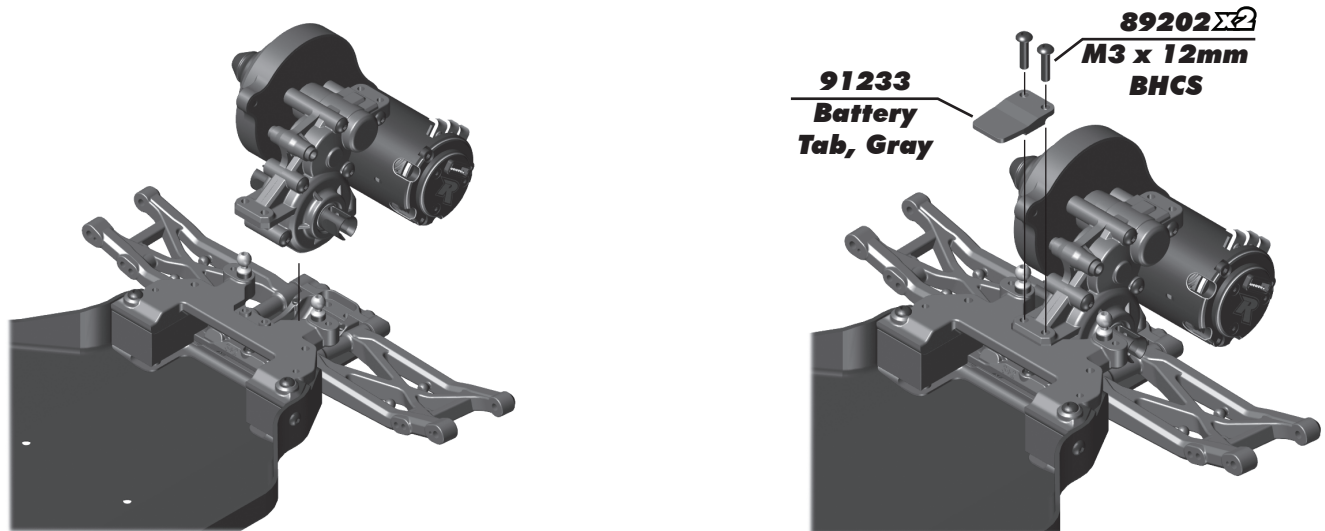

:: Gearbox Build - Bag 3 - Step 10

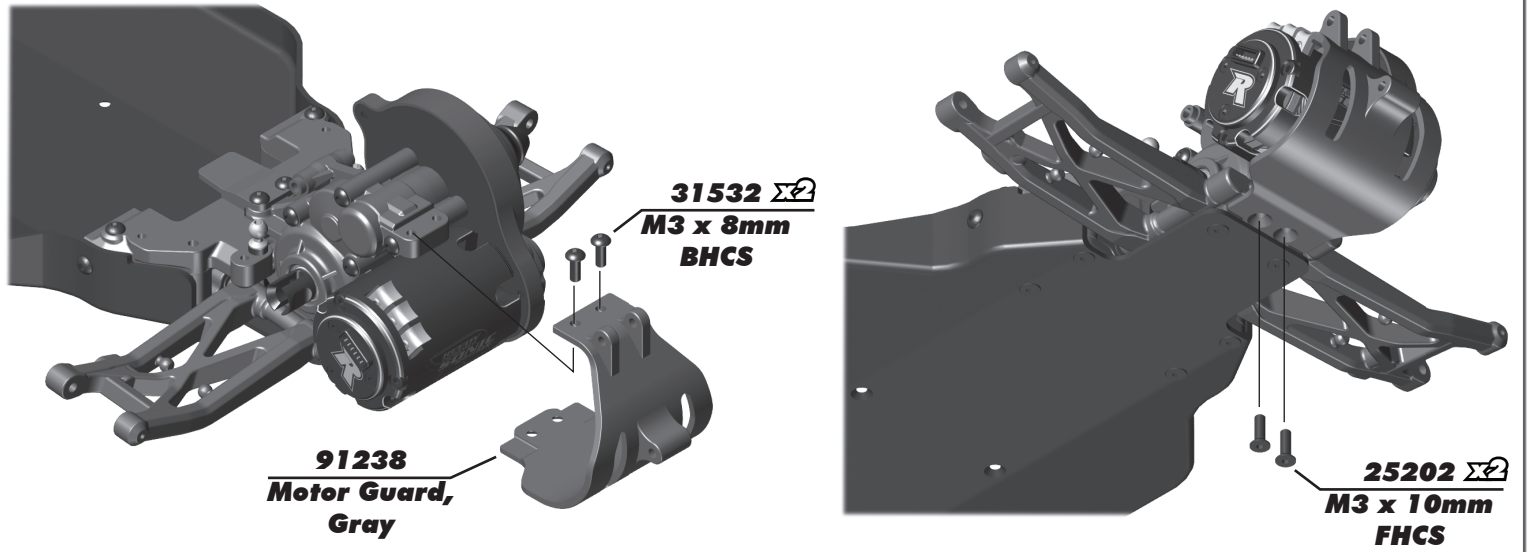

:: Shock Towers Build - Bag 4 - Step 1

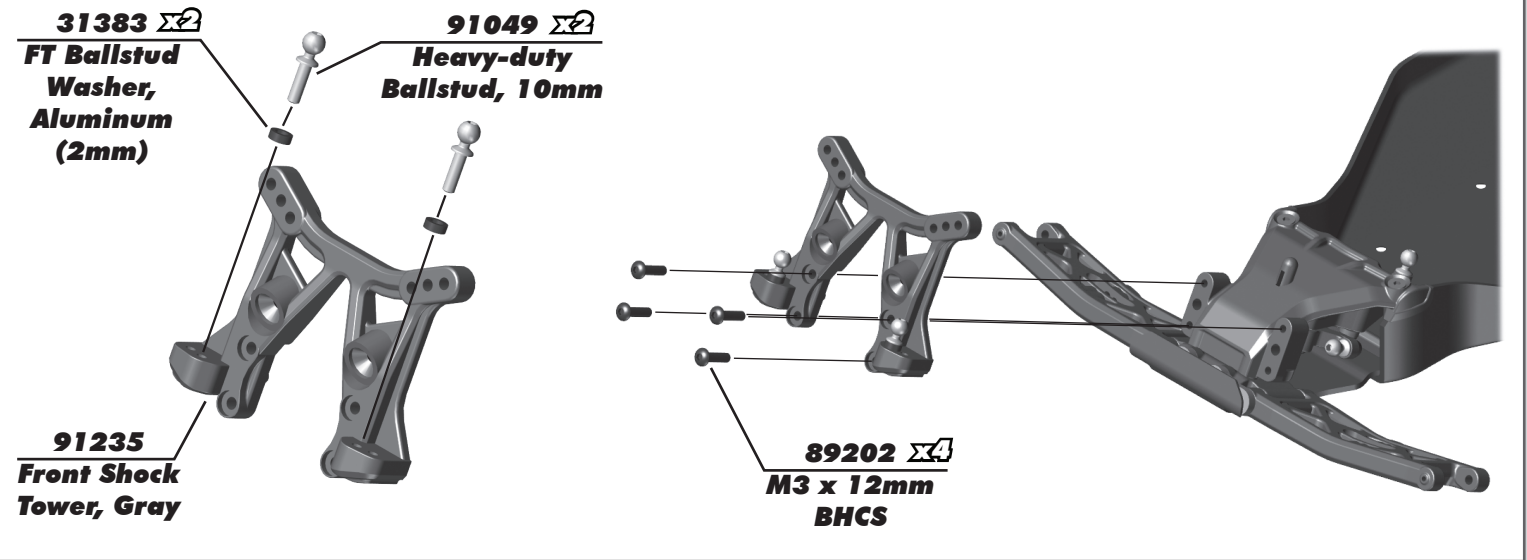

:: Shock Towers Build - Bag 4 - Step 2

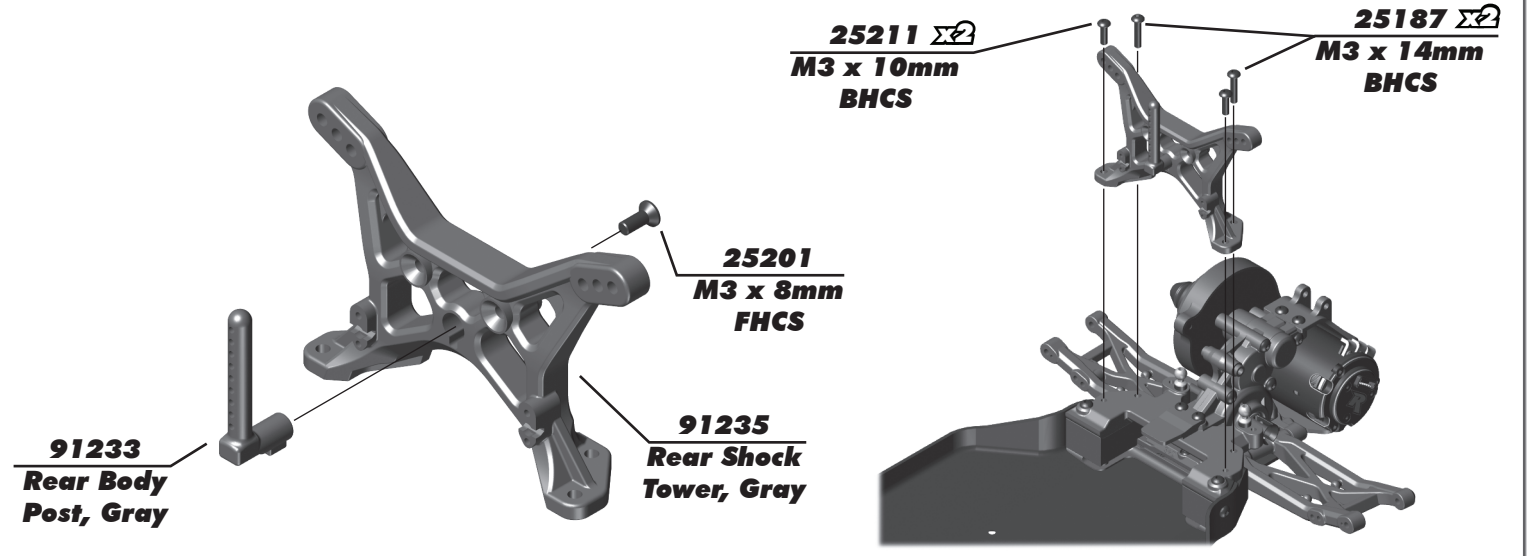

:: Front Caster / Steering Blocks Build - Bag 5 - Step 1

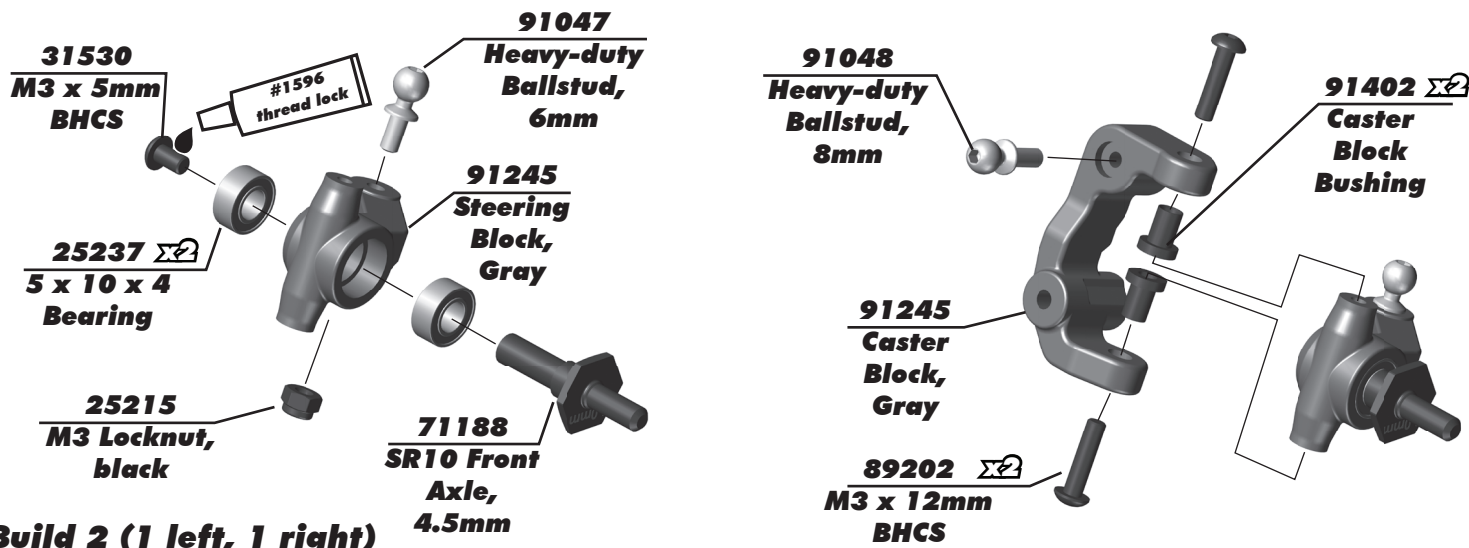

:: Front Caster / Steering Blocks Build - Bag 5 - Step 2

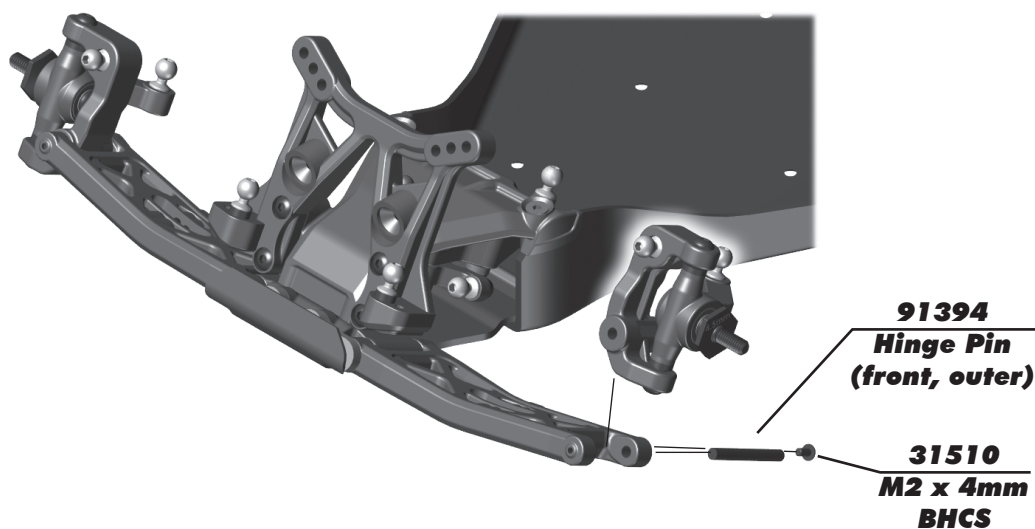

:: Rear Hub and CVA Build - Bag 5 - Step 3

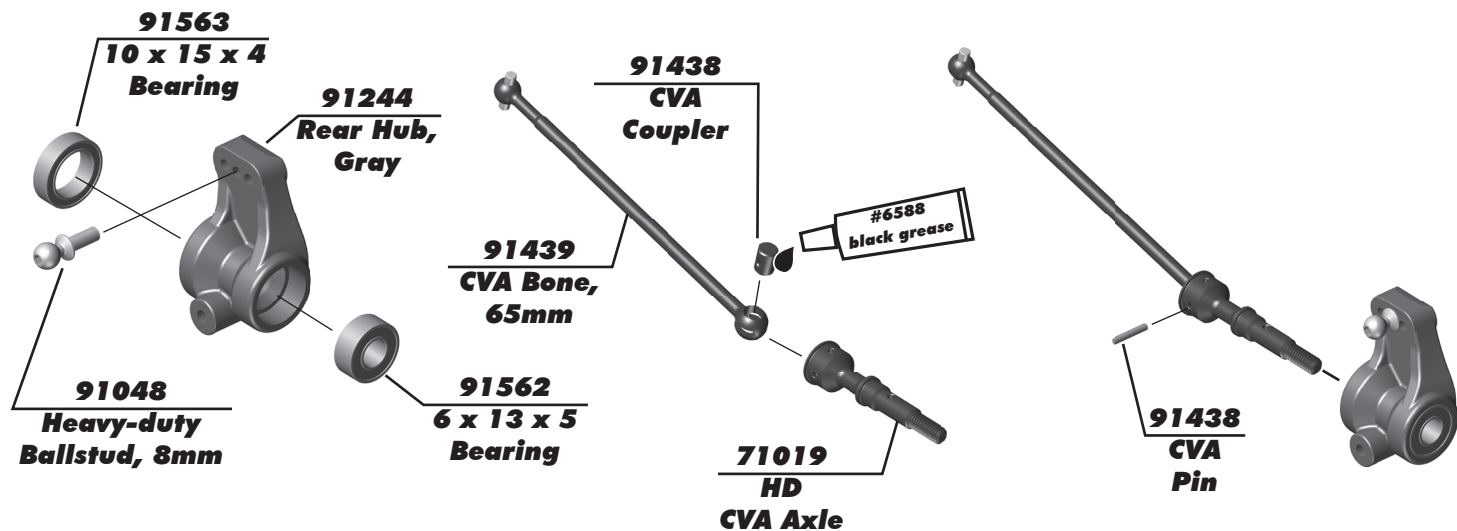

:: Rear Hub and CVA Build - Bag 5 - Step 4

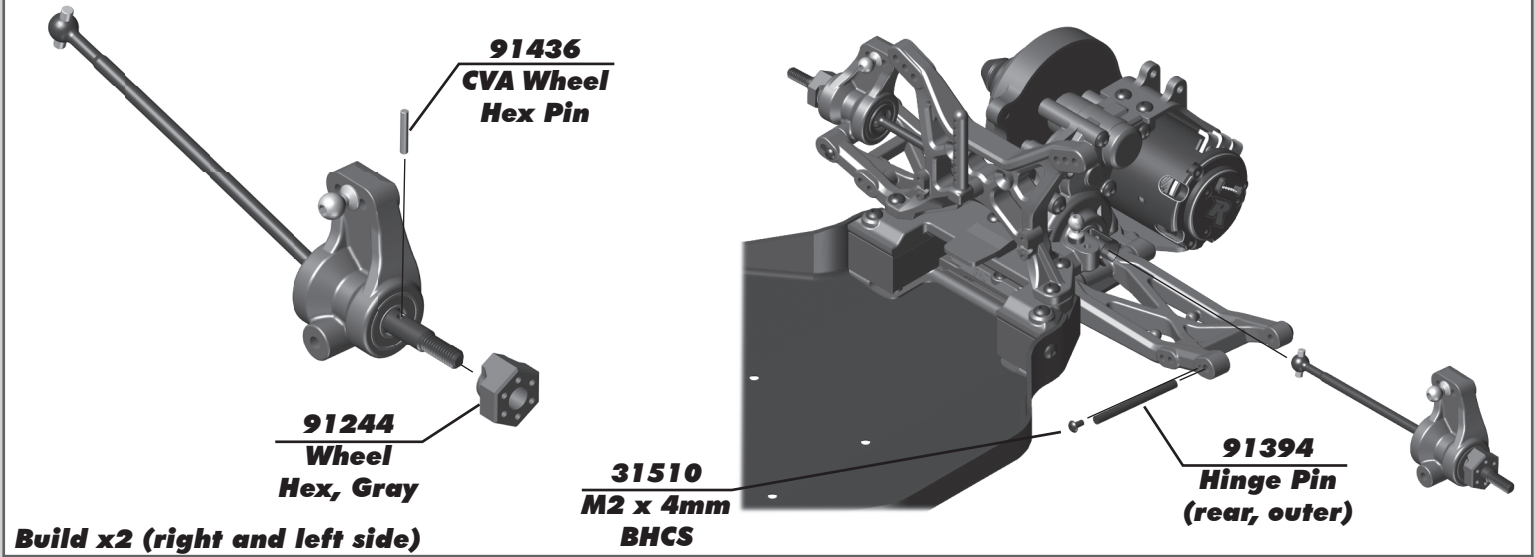

:: Turnbuckles Build - Bag 5 - Step 5

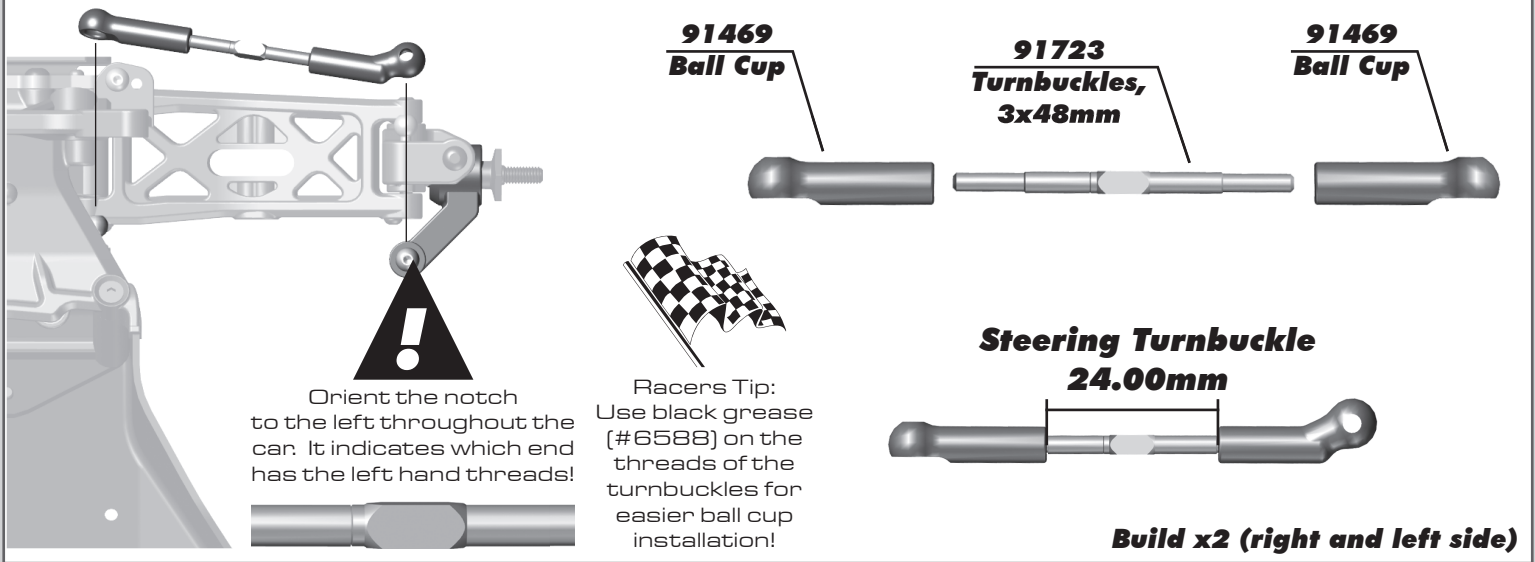

:: Turnbuckles Build - Bag 5 - Step 6

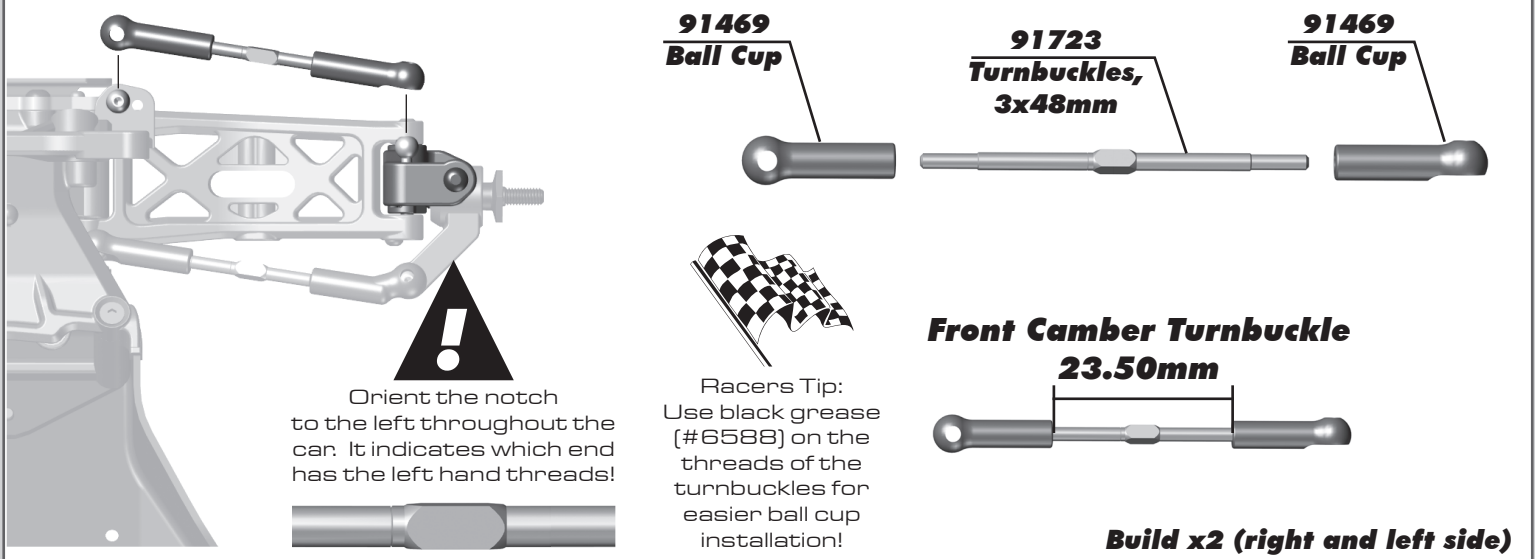

:: Turnbuckles Build - Bag 5 - Step 7

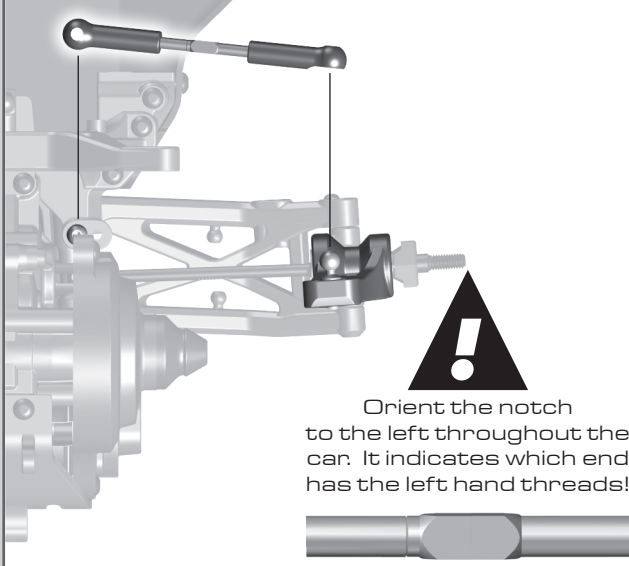

Orient the notch to the left throughout the car. It indicates which end has the left hand threads!



91469
Ball Cup



91723
Turnbuckles,
3x48mm



91469
Ball Cup



Racers Tip:
Use black grease (#6588) on the threads of the turnbuckles for easier ball cup installation!

Rear Camber Turnbuckle

23.50mm



Build x2 (right and left side)

:: Shocks Build - Bag 6 - Step 1

91444
12mm
Shock Piston
2x1.6mm

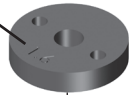

6299
1/8 E-Clip



91488
3 x 21
Shock Shaft
(front)

91489
3 x 27.5
Shock Shaft
(rear)



Racers Tip:

Use a marker over the numbers on the pistons to make them easily visible!

6299
1/8 E-Clip

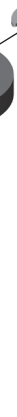

:: Shocks Build - Bag 6 - Step 2

71191
Shock Body
12 x 23mm
(front)

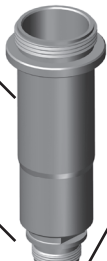

71051
Shock Body
12 x 27.5mm
(rear)

91444
Shock
Internals

91243
Shock
Bottom Cap,
Gray

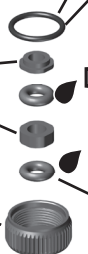

Lightly rub shock oil on the o-ring before installation!

31327
Shock
Bottom Cap
O-Ring

#1105
green slime

5407
O-Ring



Racers Tip:

Coating the o-rings with green slime (#1105) helps seal & reduce o-ring swell! **Green slime not included in kit!**



Front



Rear

91491
Shock Cap
O-Ring



91469
Shock
eyelet

91469
Shock
Pivot Ball



:: Shocks Build - Bag 6 - Step 3

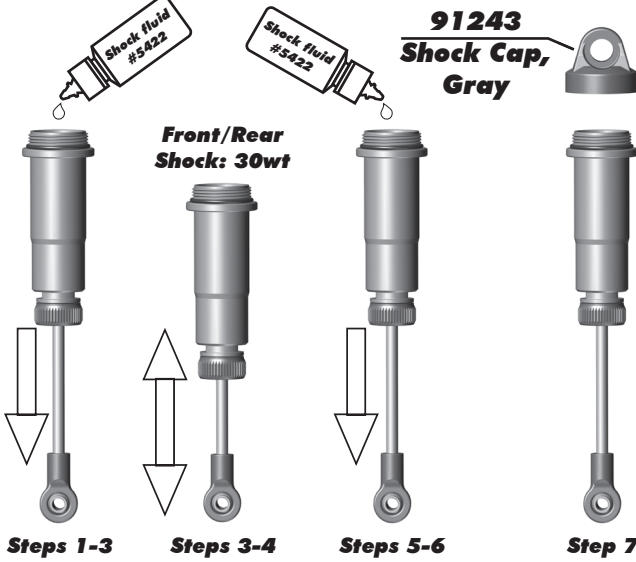

Shock Bleeding Steps:

1. Pull shock shaft down.
2. Fill shock body 3/4 full with silicone fluid.
3. Slowly move the shock shaft up and down to remove air from under piston.
4. Wait for bubbles to come to surface.
5. Fill shock body to top with silicone fluid.
6. Place a drop of oil in the cap and on cap threads.
7. Install cap and tighten completely.
8. Slowly compress shaft all the way to the top. If there is pressure at the top of the stroke, there is too much oil or air. You must bleed it out.
9. Slowly pull shaft out.
10. Unscrew the cap 3/4 turn and tilt the shock at a slight angle.
11. Slowly compress the shaft to push out excess oil and air. You should see bubbles coming out from under the cap.
12. With the shaft compressed, tighten the cap and re-check for pressure at the top of the stroke. If there is still pressure, repeat steps 9 thru 11.

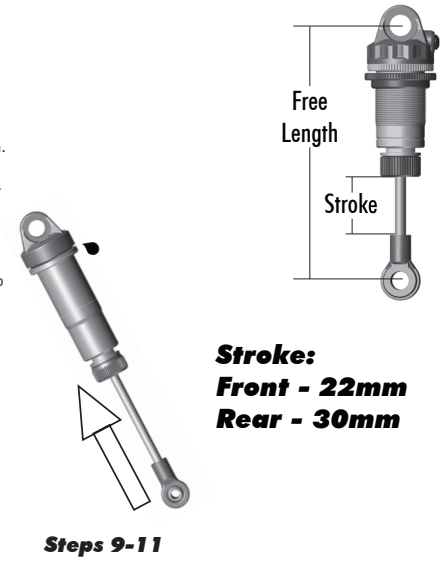

:: Shocks Build - Bag 6 - Step 4

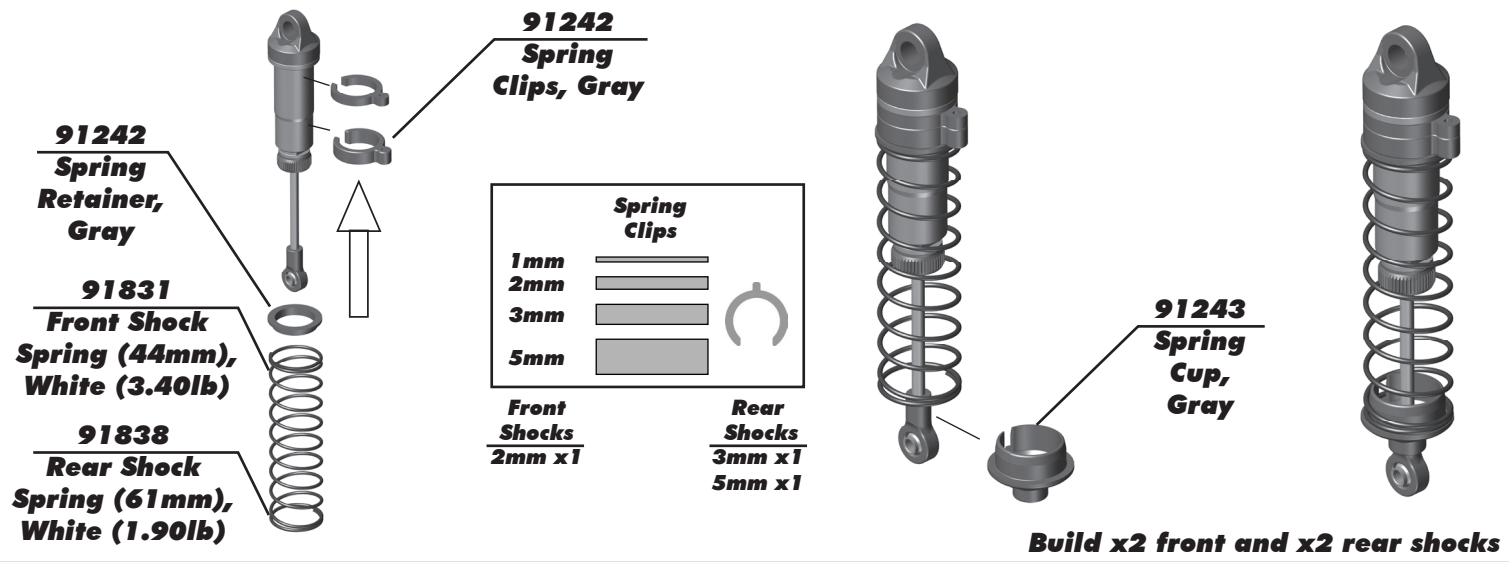

:: Shocks Build - Bag 6 - Step 5

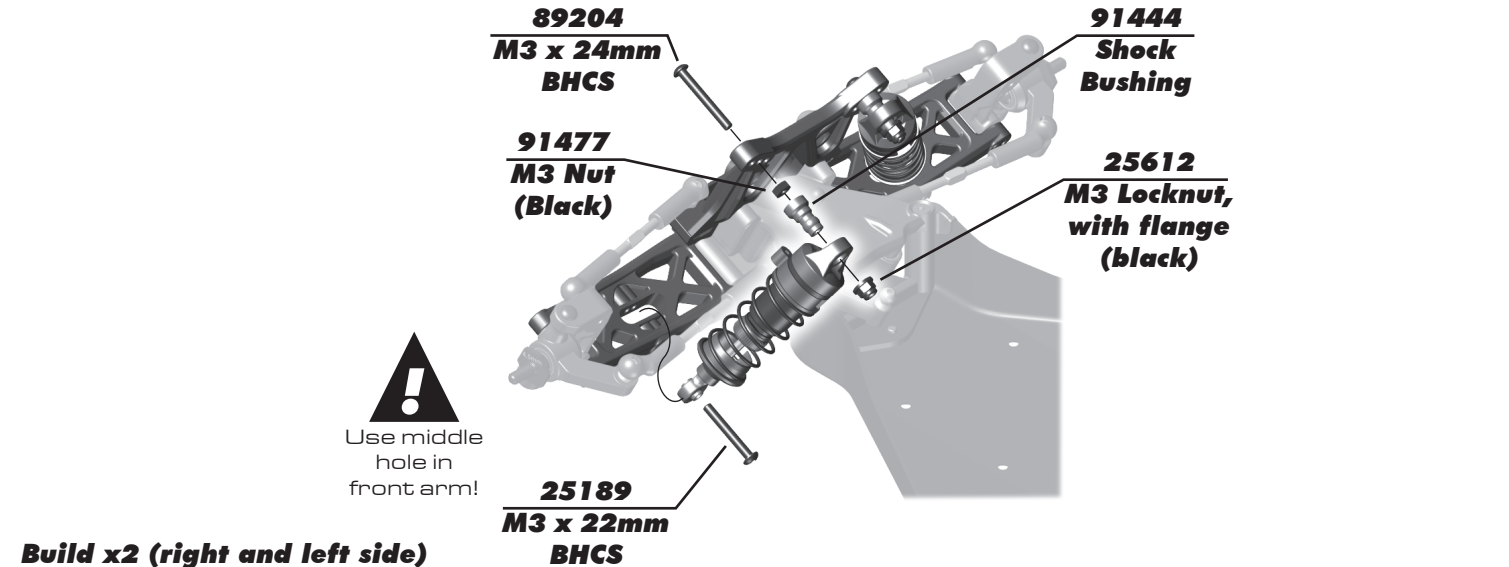

:: Shocks Build - Bag 6 - Step 6

91477
M3 Nut
(Black)

91444
Shock
Bushing

25612
M3 Locknut,
with flange
(black)

89204 $\Sigma 2$
M3 x 24mm
BHCS

89202
M3 x 12mm
BHCS

Build x2 (right and left side)

!
Use outside
hole in
rear arm!

:: Electronics Build - Bag 7 - Step 1

Servo
Not
Included

91246 $\Sigma 2$
Servo
Mount,
Gray

31532 $\Sigma 4$
M3 x 8mm
BHCS

7337 $\Sigma 4$
.250x.125x.015
Washer

91047
Heavy-duty
Ballstud, 6mm

91237
Servo Saver,
Gray

:: Electronics Build - Bag 7 - Step 2

!
Align the servo horn 90 degrees.
Adjust steering trim once vehicle
is complete.

25201 $\Sigma 2$
M3 x 8mm
FHCS

91469
Steering
Link

25201 $\Sigma 2$
M3 x 8mm
FHCS

:: Electronics Build - Bag 7 - Step 3

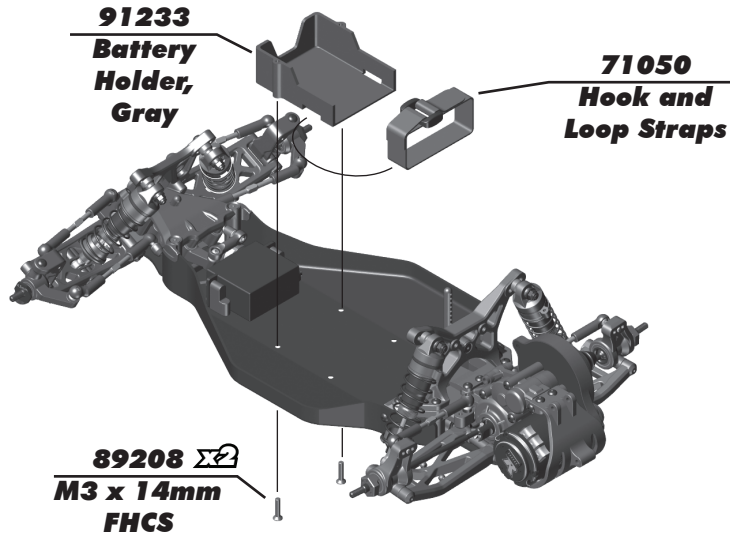

Note:
Receiver box included in this kit if you so choose to use it.
Tape it to the chassis.

:: Wing Mount Build - Bag 8 - Step 1

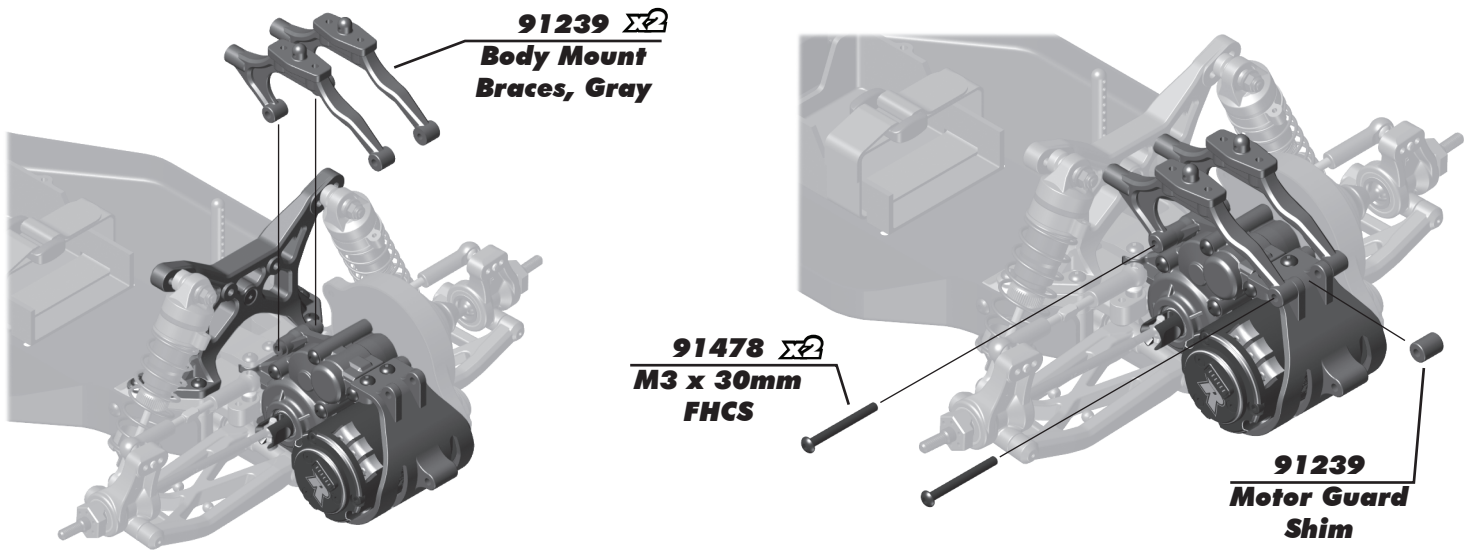

:: Wing Mount Build - Bag 8 - Step 2

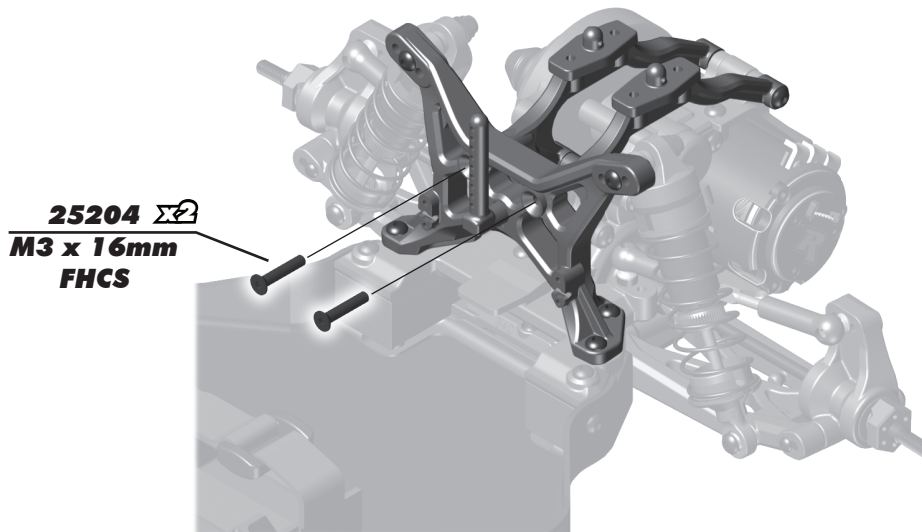

:: Wing Mount Build - Bag 8 - Step 3

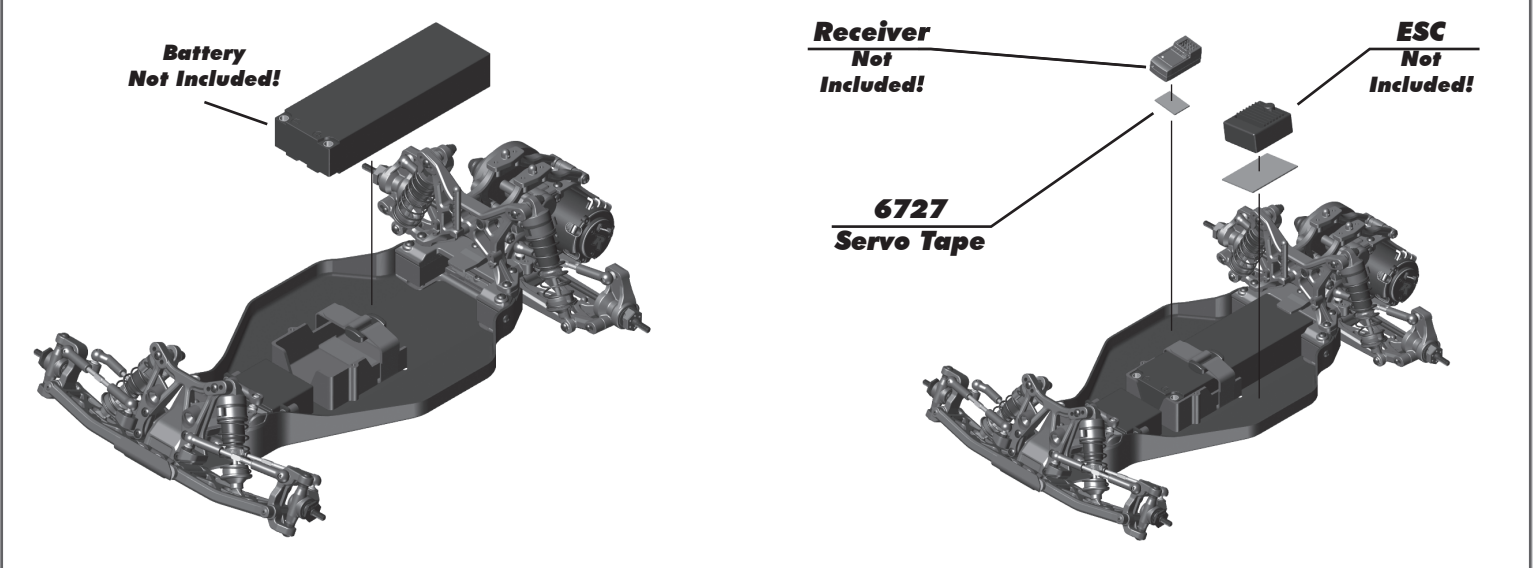

:: Body and Wing Build - Step 1

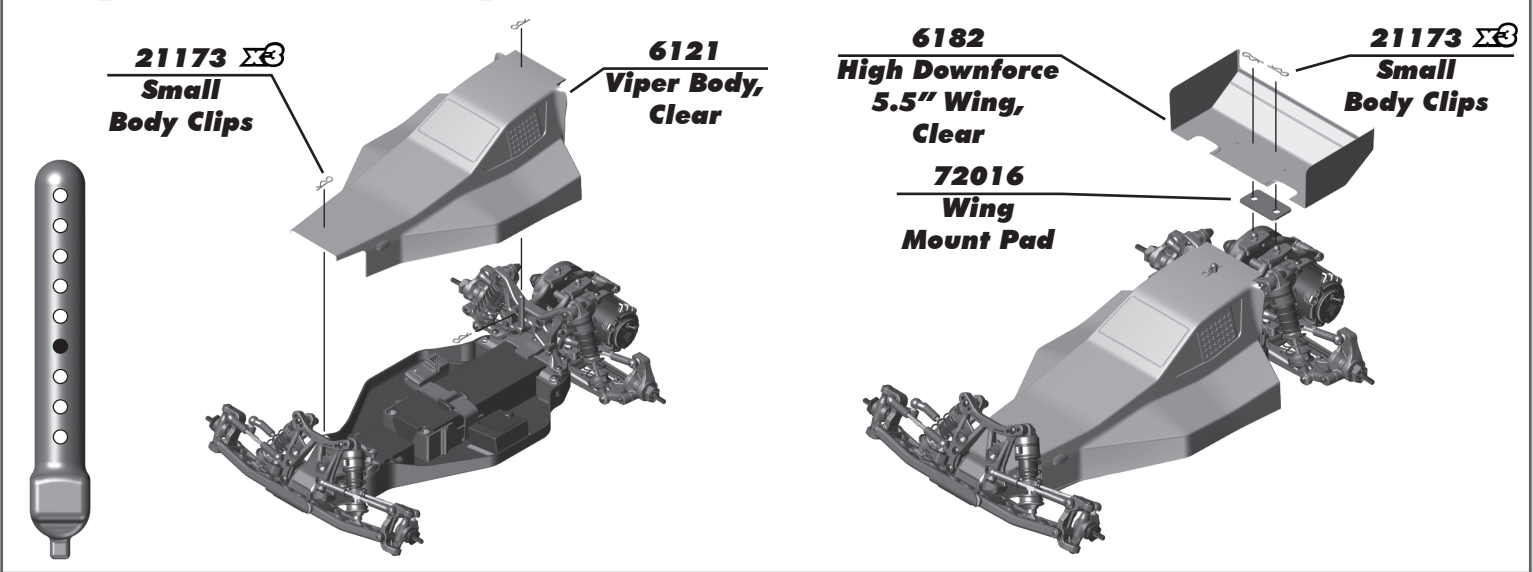

:: Wheels and Tires Build - Bag 9 - Step 1

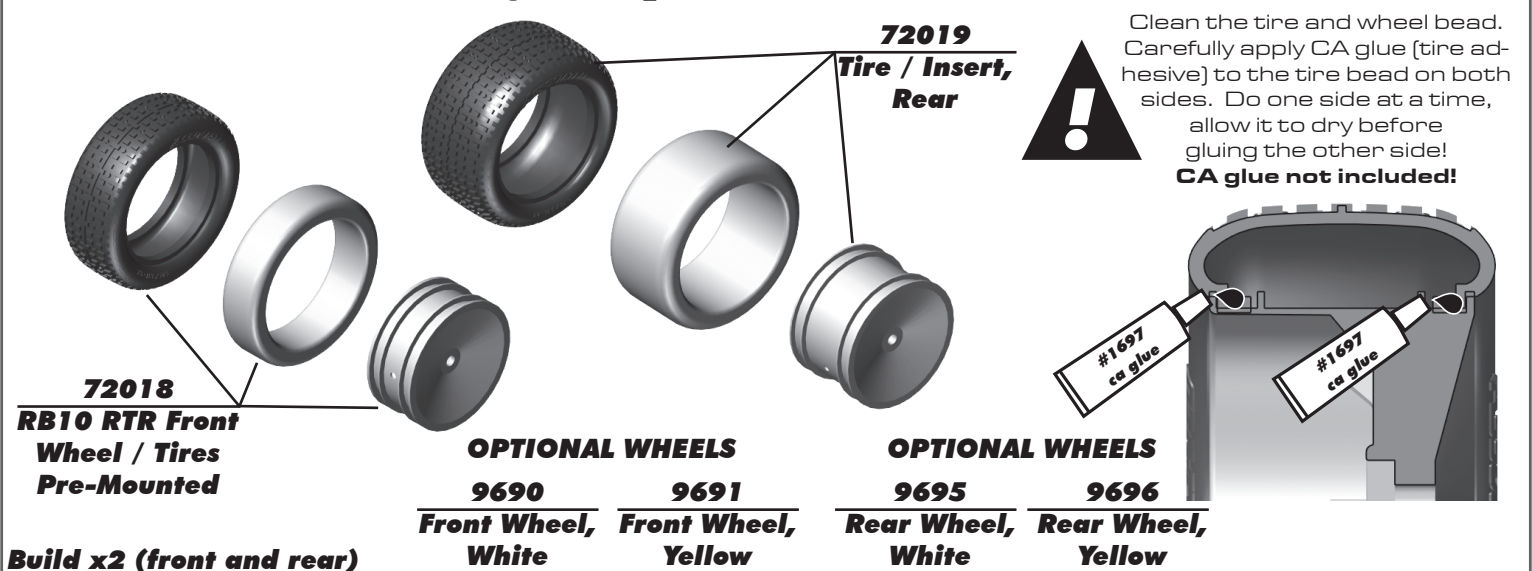

:: Wheels and Tires Build - Bag 9 - Step 2

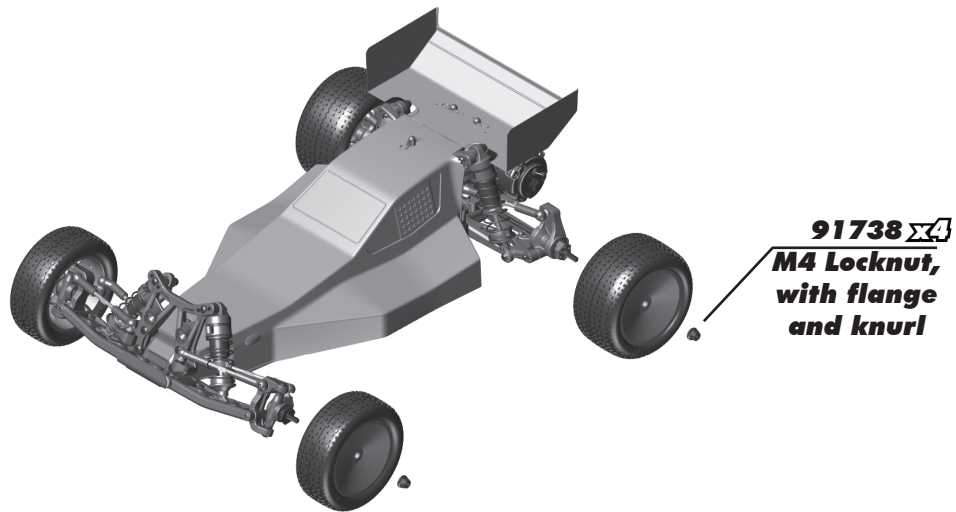

:: Tuning Tips

Tips for Beginners:

Once you can get around the track consistently, start tuning your vehicle. Make only ONE adjustment at a time, testing it before making another change. If the result of your adjustment is a faster lap, mark the change on the included setup sheet (make additional copies of the sheet before writing on it). If your adjustment results in a slower lap, revert back to the previous setup and try another change.

Periodically check all moving suspension parts. Suspension components must be kept clean and move freely without binding to prevent poor and/or inconsistent handling.

Motor Gearing:

Proper motor gearing will result in maximum performance and run time while reducing the chance of overheating and premature motor failure. The gear ratio chart lists recommended **suggested starting gear ratios** for the most widely used motor types. Gear Ratios will vary depending upon motor turns or KV, electronic speed control specifications and whether you are running 6-cell NiMh or 2S or 3S LiPo batteries.

Gear ratios listed below are suggested based on 6-cell NiMh and or 2S LiPo battery.

Team Associated is not responsible for motor damage due to improper gearing.

Gear Ratio Chart (Internal Gear Ratio 2.60:1)

Motor	Pinion	Spur	Final Drive Ratio
17.5 Reedy Sonic Brushless	*28	*75	6.96:1
13.5 Reedy Sonic Brushless	*26	*75	7.50:1
17.5 Reedy Sonic Brushless	*29	81	7.26:1
13.5 Reedy Sonic Brushless	*26	81	8.10:1

* **Optional spur gear / pinion used**

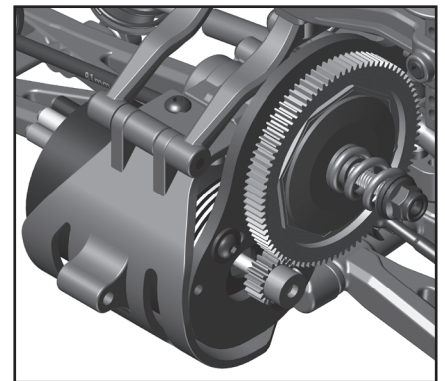

Set The Gear Mesh:

You should be able to rock the spur gear back and forth in the teeth of the pinion gear without making the pinion gear move. If the spur gear mesh is tight, then loosen the #31532 screws and move the motor away, then try again. A gear mesh that is too tight or too loose will reduce power and damage the gear teeth.

:: Tuning Tips (cont.)

Slipper Clutch:

The assembly instructions give you a base setting for your slipper clutch. Turn the nut on the shaft so that the end of the top shaft is flush with the nut. At the track, tighten or loosen the nut in 1/8 turn increments until you hear a faint slipping sound for 1-2 feet on takeoff. Another popular way to set the clutch is to hold both rear tires firmly in place and apply short bursts of throttle. If the clutch is properly set, the front tires should lift slightly up off the surface.

Ride Height:

Ride height is the distance from the ground to the bottom of the chassis. The standard front ride height setting is with the front arms level (referred to as "arms level") or 30mm.

Check the ride height by lifting up the entire car about 8-12 inches off the bench and drop it. After the suspension "settles" into place, measure ride height. Add or remove pre-load spacers as necessary so that the left & right arms appear to be level.

The rear ride height setting you should use most often is with the outrdrive, driveshaft, and axles all on the same imaginary horizontal line (referred to as "bones level") or 28mm.

Check the ride height by lifting up the entire car about 8-12 inches off the bench and drop it. After the suspension "settles" into place, measure ride height. Add or remove spring clips as necessary so that the left & right driveshafts appear to be level.

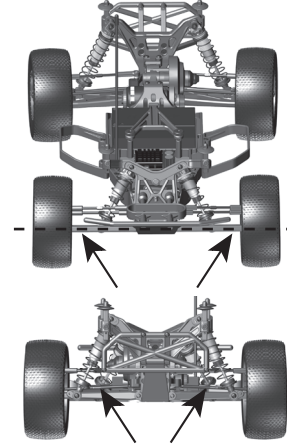

!
Front arms inner and outer hinge pins should be in a imaginary horizontal line when ride height is set

!
CVA bones should be in a straight line when ride height is set at "CVA bones level"

Front Camber:

Camber describes the angle at which the tire and wheel rides when looked at from the front. Negative camber means that the tire leans inward at the top. A good starting camber setting is -1° . Positive camber, where the top of the tire is leaning out, is not recommended. A camber gauge can be used to more accurately set camber.

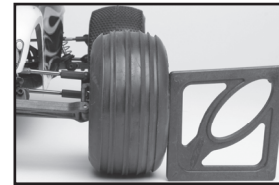

!
Testing camber with camber gauge

Rear Camber:

Camber describes the angle at which the tire and wheel rides when looked at from the back. Negative camber means that the tire leans inward at the top. A good starting camber setting is -1° . Adding a small amount of positive camber, where the top of the tire is leaning out, will tend to improve straight-line acceleration on loose tracks. A camber gauge can be used to more accurately set camber.

Front Camber Links:

Changing the length of the camber link is considered a bigger step than adjusting the ball end height on the tower. Shortening the camber link (or lowering the ball end) will give the front end less roll and quicken steering response. Lengthening the camber link (or raising the ball end) will give the front more roll and slower steering response. Longer camber links are typically used on high grip tracks and shorter links tend to work better on medium-grip loose tracks.



!
Raise or lower the ball end by adding or subtracting washers here

Rear Camber Link:

Changing the length of the camber link (see page 15) is considered a bigger step than adjusting the ball end height on the rear chassis brace. Shortening the camber link (or lowering the ball end) will give the rear end less roll and the car will tend to accelerate or "square up" better. Lengthening the camber link (or raising the ball end) will give the rear more roll and more cornering grip. Longer camber links are typically used on high grip tracks, while shorter links tend to work better on medium grip loose tracks. The kit setting is the best compromise of cornering grip and acceleration.

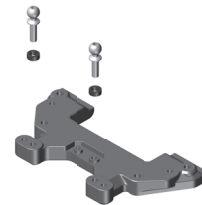

!
Raise or lower the ball end by adding or subtracting washers here

Ackermann:

Ackermann is the angle difference between the front wheels when they are turned to steer the car. For minimal tire slip, it is standard for the inside wheel to steer to a greater angle than the outside wheel. The RB10 allows Ackermann adjustments by changing the washer thickness used behind the steering rack ballstuds. If corner entry steering is too aggressive, try increasing the Ackermann by removing shims from behind the steering rack ballstuds. Increasing the Ackermann will increase the angle difference of the front wheels when steered, resulting in a more stable car on corner entry.

:: Notes

A large, empty rectangular area intended for taking notes, framed by a thin black border.

:: Notes

A large, empty rectangular area intended for taking notes, framed by a thin black border.



Associated Electrics, Inc.
21062 Bake Parkway Lake Forest, CA 92630 USA

call: (949) 544-7500 - fax: (949) 544-7501
Check out the following web sites for all of our kits, current products,
new releases, setup help, tips, and racing info!
www.AssociatedElectrics.com

FOLLOW US ON SOCIAL MEDIA



TeamAssociated
ReedyPower
ElementRC
FactoryTeam51



@TeamAssociatedRC
@ReedyPower
@Element_RC
@FactoryTeam_RC



@Team_Associated
@ReedyPower



@Associated_Electrics



TeamAssociatedRC
ElementRC



TeamAssociated
Reedy
Element-rc