

#2284 2-SPEED INSTALLATION

How to remove your 1-speed parts and replace them with the 2-speed parts

You'll need:

Allen wrenches 1/16," 3/32," and 5/64"

Small, flat blade screwdriver.

Needlenose pliers.

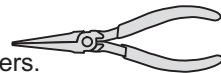

step 1

TOOLS USED:

Allen wrench, 3/32" & 5/64"
Needlenose pliers

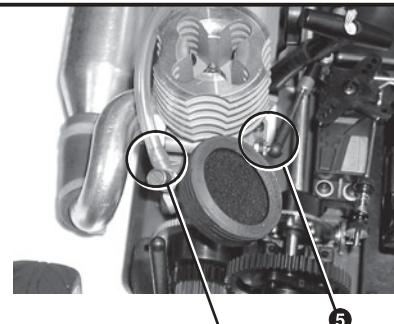
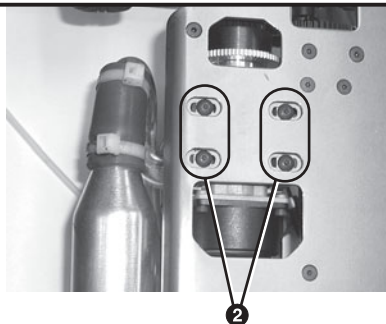
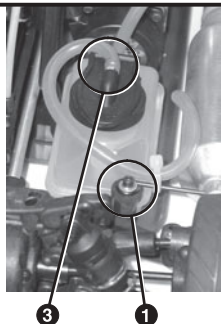

REMOVE ENGINE FROM CAR

- 1 Remove the #6924 exhaust pipe wire mount screw (with your 3/32" Allen wrench) and #3216 washer.
- 2 Remove the four #7773 engine screws from under the car with your 5/64" Allen wrench.
- 3 Release the #7724 fuel tube attached to the lid of the tank. (This is the pressure line. The opposite end leads to the pipe.)
- 4 Release the #7724 fuel tube attached to the carburetor. (This is the fuel delivery line. The opposite end leads to the surface of the tank.)
- 5 Pop off the #2326 throttle rod with your needlenose pliers. Remove the engine from the car.

step 2

TOOL USED:

Allen wrench, 3/32"

REMOVE SINGLE SPEED FROM CAR

- 1 Remove the six #6924 screws from the upper rear transmission case with your 3/32" Allen wrench. (It is not necessary to remove the shock tower from the upper transmission case.)
- 2 Remove the two #6924 screws from the #2269 bearing cap with your 3/32" Allen wrench.
- 3 Lifting up the #2250 rear shock tower/upper rear transmission assembly, remove the entire single speed input shaft assembly.

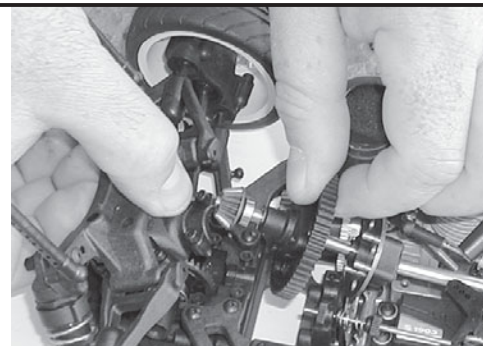
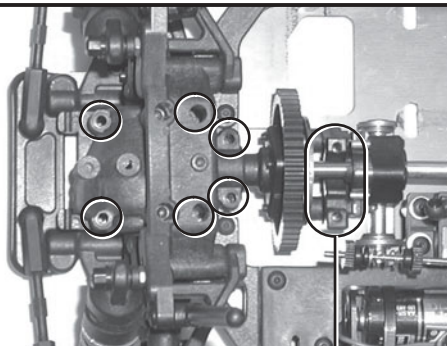

step 3

TOOLS USED:

Allen wrench, 1/16"
Needlenose pliers

DISASSEMBLE SINGLE SPEED

From the single speed input shaft assembly, remove the #5407 O-ring, #6920 screw (with your 1/16" Allen wrench), #2270 drive cup, #2281 brake disc, #2291 dowel pin (with your needlenose pliers), #2293 input shaft shim, and the #3977 bearing.

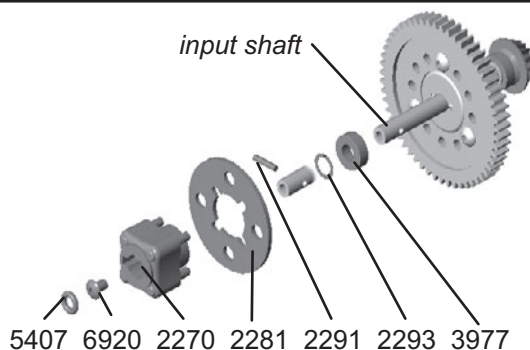

step 4

TOOLS USED:

Small, flat-tipped screwdriver
Needlenose pliers

DISASSEMBLE SINGLE SPEED

From the drive pinion side, remove the #6299 small E-clip (with your small, flat-tipped screwdriver), the #3903 drive pinion, #2291 dowel pin (with your needlenose pliers), #2293 input shaft shims, and the #3977 bearing.

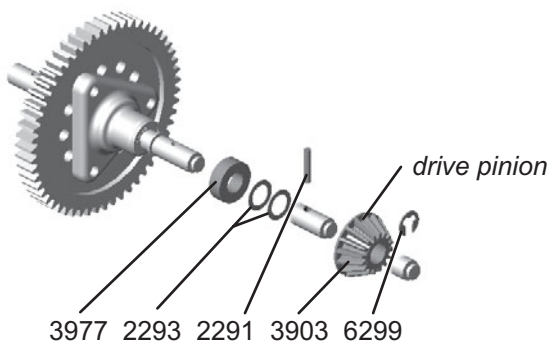

step 5

TOOLS USED:
Small, flat-tipped screwdriver
Needlenose pliers

ASSEMBLE THE TWO-SPEED

- 1 On the clutch shoe side of your 2-speed input shaft, slide the #3977 bearing onto the shaft, followed by the #2293 input shaft shim.
- 2 Install and center the #2291 dowel pin into the input shaft with your needlenose pliers.
- 3 Place #2281 brake disc onto the #2270 drive cup, aligning the drive cup pins in the brake disc notches.
- 4 (Not shown.) Slide the drive cup with brake disc onto the input shaft, over the dowel pin that is centered on the shaft.
- 5 Tighten it down with one #6920 screw using your 1/16" Allen wrench.
- 6 Slide one #5407 O-ring into the drive cup.

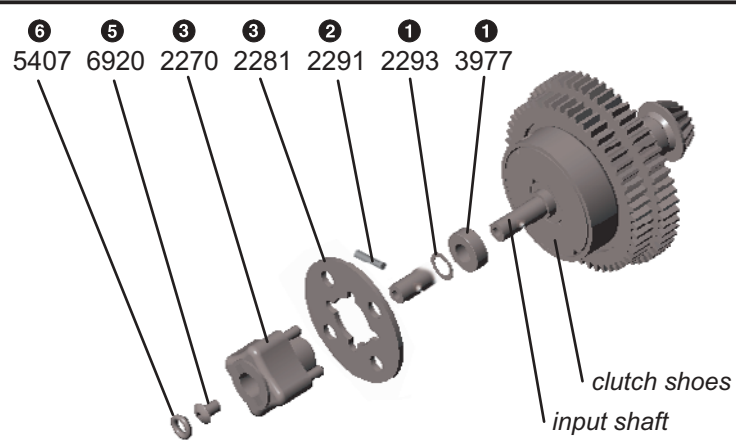

step 6

TOOL USED:
Needlenose pliers.

ASSEMBLE THE TWO-SPEED

- 1 On the pinion gear side of your 2-speed, slide the #3977 bearing and two #2293 input shaft shims onto the input shaft.
- 2 Install and center the #2291 dowel pin into the input shaft with your needlenose pliers.
- 3 Slide the #3903 drive pinion onto the end of the input shaft. Line up the slot in the back of the #3903 drive pinion with the #2291 dowel pin and push it OVER the dowel pin that is centered on the input shaft.
- 4 Add a #6299 small E-clip with your needlenose pliers.

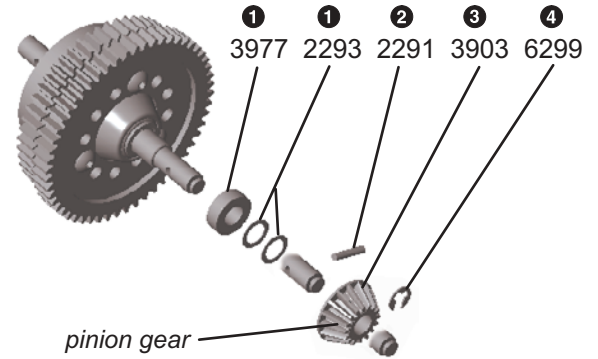

step 7

TOOL USED:
Allen wrench, 3/32"

INSTALL TWO-SPEED INTO THE CAR

- 1 Place one end of the drive shaft into the drive cup of your two-speed assembly. The shaft may be a slightly snug fit in the cup. Install the opposite end of the driveshaft into the front drive cup.
- 2 While lifting up on the rear shock tower/upper transmission case assembly, set the input shaft (two-speed) into place, making sure the brake disc is placed between the brake pads.

NOTE: When installing the transmission and bearing cap screws in the next steps, turn the screws counterclockwise until they drop into the original threads in the plastic, then tighten. This will help to prevent starting a new set of threads in the plastic, which could result in loose screws.

- 3 Lower the rear shock tower/upper transmission case assembly into place and secure with the six #6924 screws using the 3/32" Allen wrench.
- 4 Align the #2269 bearing cap over the bearing and attach with two #6924 screws with a 3/32" Allen wrench. Do not over-tighten.

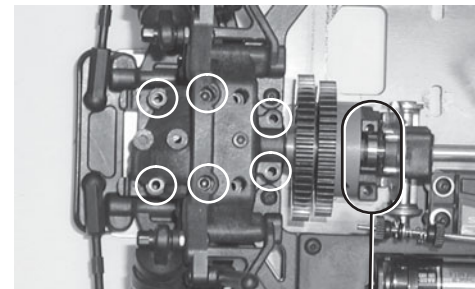
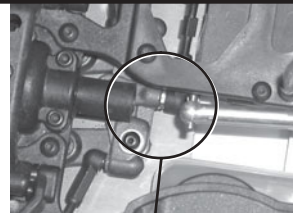
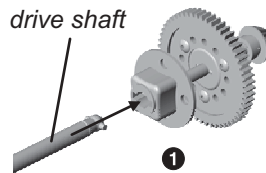

step 8

TOOL USED:
Allen wrench, 5/64"

REMOVE SINGLE SPEED CLUTCH BELL FROM ENGINE

- 1 While gripping the flywheel, remove the #3934 screw with your 5/64" Allen wrench.
- 2 Remove the two #2321 shims and the #2316 clutch bell.
- 3 Remove the #2320 flanged and the non-flanged bearings from the clutch bell. It's possible the non-flanged bearing may still be on the motor shaft. If it is, remove it and set it aside.
- 4 Remove the #2321 clutch shim from the shaft. It's possible the clutch shim will be stuck to the back of the oiled #2320 non-flanged bearing. If it is, remove the shim from the bearing and set it aside. Both of these will be used when installing your 2-speed assembly to the engine.

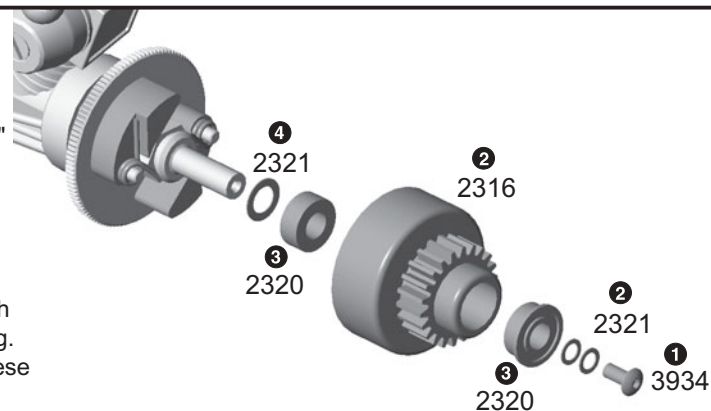

step 9

TOOL USED:
Allen wrench, 5/64"

ASSEMBLE THE TWO-SPEED CLUTCH BELL

- 1 Thread the #2299 (black) 26 tooth pinion onto the #2295 clutch bell, making sure the shoulder side of the pinion (see photo) goes on first.
- 2 Thread on the second #2297 (blue) 22 tooth pinion onto the clutch bell, making sure the shoulder side of the pinion (see photo) goes on first.
- 3 Slide on one #2321 clutch shim (that you removed from the engine in step 8, previous page) followed by the #2320 non-flanged clutch bearing.
- 4 Slide on the clutch bell assembly (see note below). Insert the #2320 flanged clutch bearing into the front (gear) side of the clutch bell.
- 5 Slide on two #2321 shims onto the #3934 screw, insert the screw, and tighten down the clutch bell with your 5/64" Allen

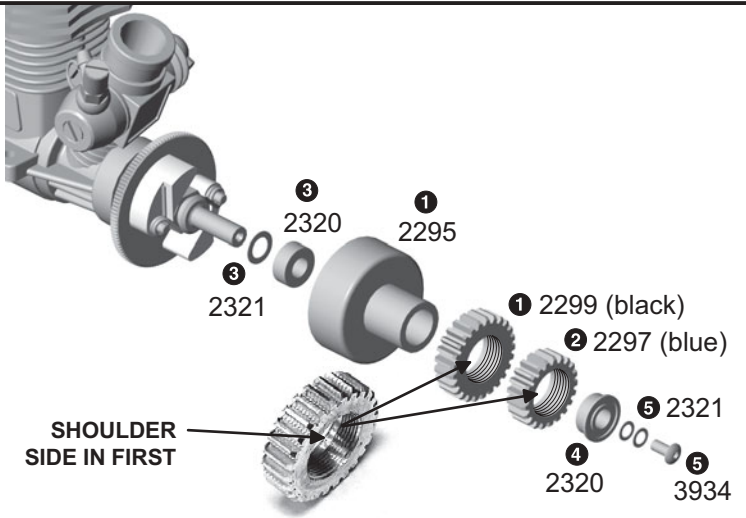

NOTE: Install the clutch bell assembly so it is not fully seated on the shaft, then install the #3934 screw and the two #2321 shims. Insert the flanged bearing (in the front of the clutch bell) and ensure BOTH shims are in the center of the bearing before you tighten the #3934 screw with your 5/64" Allen wrench. If the shims are not seated properly in the bearing, it could bind the clutch bell housing. The clutch bell housing, when properly assembled, should spin very freely.

step 10

TOOL USED:
Allen wrench, 3/32" & 5/64"

INSTALL ENGINE BACK INTO CAR

- 1 Place your engine assembly on to the chassis. (Make sure the black ball cup of the #2326 throttle rod is facing the REAR of the car.) Attach the engine to the chassis with the four #7773 screws with your 5/64" Allen wrench. Do not tighten the screws yet.
- 2 Now set the spur-to-pinion gear spacing, otherwise known as gear mesh. With the engine mount screws still loose, it should be possible to slide the engine left to right, allowing you to set the mesh properly between the clutch bell pinions with the spur gears.

The correct gear spacing is when the pinion is close to the spur gear, but if you hold the pinion gears, you should still be able to rock the spur gears back and forth slightly with light pressure.

Roll the gears and check the mesh in several different locations on the spur gear. Now tighten the four engine mount screws with your 5/64" Allen wrench. Recheck the mesh.

- 3 Slide the #3216 washer over the #6924 screw. Attach the #2344 exhaust wire mount to the chassis with the #6924 screw using your 3/32" Allen wrench.
- 4 Attach the free end of the #7724 fuel tube that is connected to the surface of the tank to the carburetor. This is the fuel delivery line.
- 5 Attach the free end of the #7724 fuel tube that is connected to the pipe to the nipple on the lid of the fuel tank. This is the pressure line.
- 6 Connect the #2326 throttle rod back to the carburetor with your pliers.

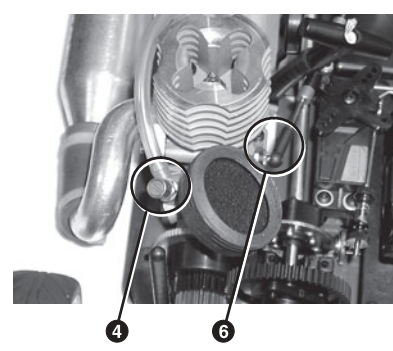
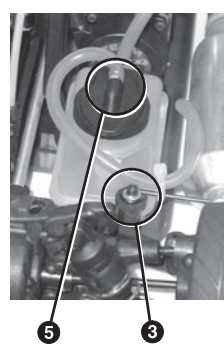
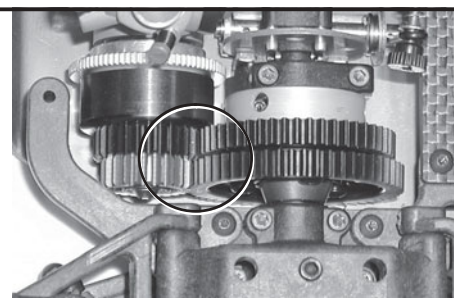
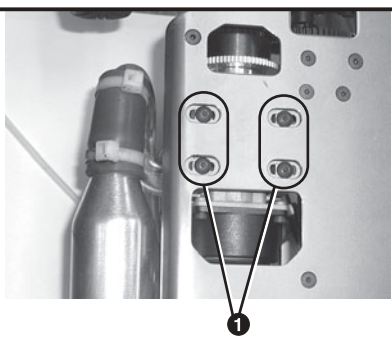

step 11

TOOL USED:
Allen wrench, 5/64"

ADJUST THE TWO-SPEED

By increasing or decreasing the spring tension you can change the shift point of your two-speed. If you want the car to shift into second gear later, tighten down both shift adjustment screws (shown at right) equally 1/8 of a turn clockwise to increase the spring tension. If you want the car to shift into second gear sooner, loosen both screws equally 1/8 of a turn counter-clockwise to decrease the spring tension. Make your adjustments in 1/8 turn increments. Run your car first before you make any adjustments to the two-speed.

To adjust your two-speed, **first turn off your engine:**

- 1 Lift the car and hold the spur gear in place with your thumb, the bell opening facing up.
- 2 Turn the rear wheel slowly.
- 3 (Not shown.) Watch for the adjustment screw to appear in the opening of the two-speed bell. It will be a black screw, at an angle (not the silver screw). When looking at the front of the two-speed, there will be a number 1 and 2 on the shoes where the adjustment screws are located.
- 4 Insert your 5/64" Allen wrench and adjust 1/8 turn as indicated in the instructions above.
- 5 Remove your wrench and turn the rear wheel again and repeat for the second black adjustment screw, adjusting it the same amount. You **MUST** adjust both sides equally. Factory setting is 3 1/2 turns out from fully tightened position.

How to determine fully tightened position

Insert your 5/64" Allen wrench into each shift adjustment screw and turn clockwise to tighten. See drawings below.

Caution: Be very careful when finding the fully tightened position of the screws because the springs can be damaged easily.

