

Factory Team Monster GT Steering Kit

Part #25395

Installing the Upgrade Servo Saver Steering Kit

Follow these steps to install your Aluminum Servo Saver Steering Kit.

Required Tools:

Phillips Screwdriver
(Part #6954)



5/64" (or 2mm) Allen Driver
(Part #6959)

Recommended Tools:

Locking Adhesive
(Part #1596)



1

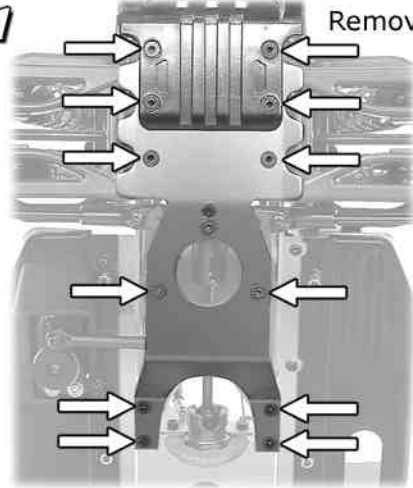

Remove 12 Screws.

Set screws & skid plate aside.



NOTE! Length of screws!

2 Remove servo screw. Remove steering linkage.

NOTE!
Carefully
remove
servo saver
from servo.

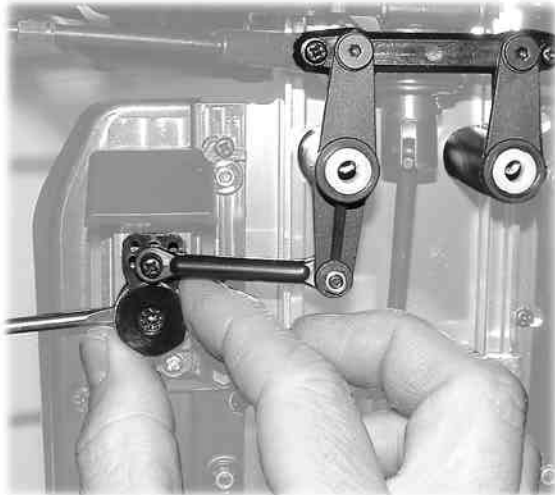

3

Remove.

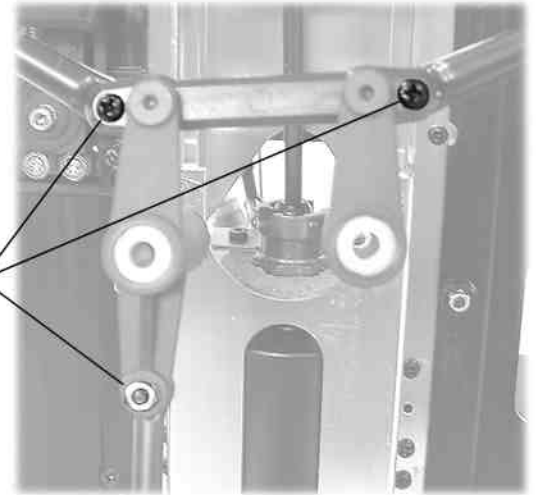

4 Open receiver box. Remove receiver. Remove 2 screws in receiver box.

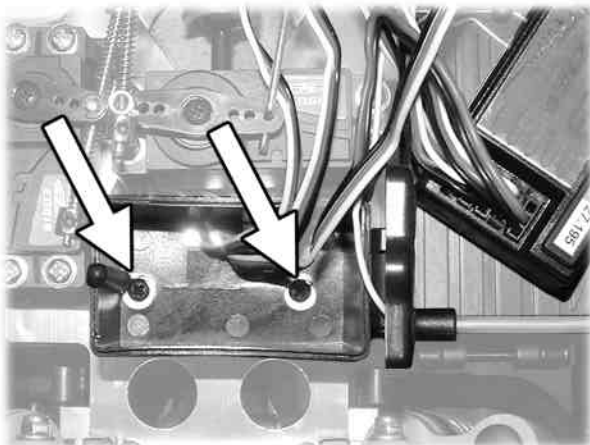

5 Assemble Factory Team Steering Linkage.



NOTE! Placement of shims.



Team Tip!

Move link up for quicker servo response, or replace with Heavy Duty servo arm available with most aftermarket servos.

6 Re-assemble steering linkage.

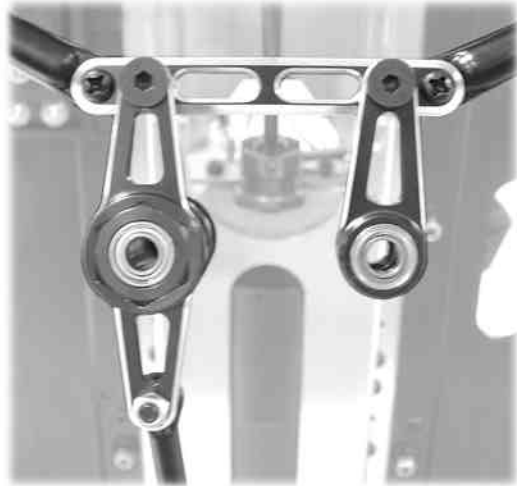

7 Attach steering linkage to truck.

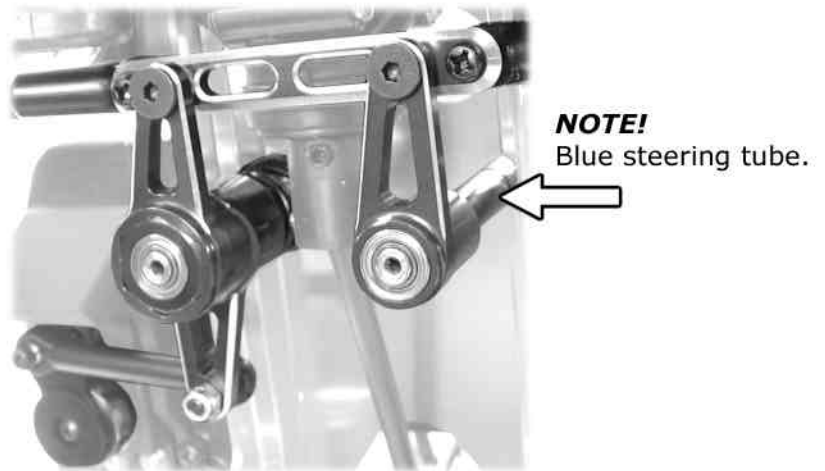

8

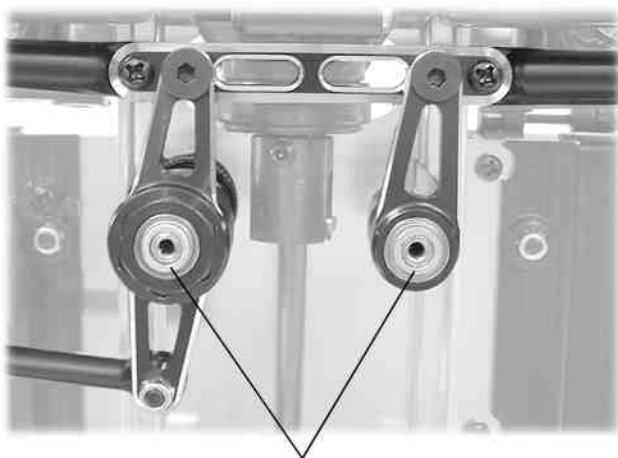

NOTE! Placement of shims.

9

Re-attach skid plate & 12 screws. **Note screw lengths from step 1.**

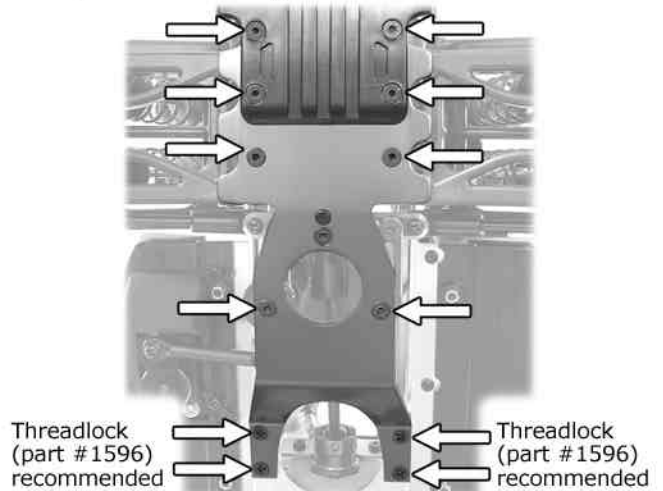

NOTE!

Using the transmitter steering trim and dual rate adjustment knobs, reset your steering so the front wheels point straight ahead and have equal throw in both left and right directions (see your Monster GT User's Guide for more information on setting these adjustments).

Optional Steering Parts

25395	Optional Steering Kit Complete Optional Monster GT Steering Kit	\$74.99
25396	Optional Steering Rack and Arm Contains Aluminum Idler Arm, Rack, Upper Servo Saver Arm and Lower Servo Saver Arm	\$54.99
25397	Optional Steering Servo Saver Hub & Spring Contains Aluminum Servo Saver Hub, Servo Saver Adjustment Nut and Servo Saver Spring	\$5.99
25398	Optional Steering Hardware Contains Rack Shoulder Screws, Rack Shims, Idler Arm Spacer and Inner Posts	\$6.99