



Your journey begins here.

For Immediate Release: November 11, 2020

Enduro Gatekeeper Rock Crawler Buggy RTR

#40111, 40111C



ELECTRIC ▪ OFF ROAD ▪ 1:10 SCALE ▪ 4 WHEEL DRIVE ▪ RTR

A PERFORMANCE RIG BUILT TO ENDURE. When hitting the trail, you want to do it with performance and confidence. The all-new Enduro Gatekeeper Rock Crawler Buggy RTR delivers this and more!

Aimed towards the serious RC rock crawler enthusiast, the new Enduro Gatekeeper Buggy RTR is packed full of performance features that are sure to impress.

What makes the Enduro Gatekeeper Buggy RTR special? The all-new Gatekeeper Suspension package (GKS™)! This package consists of rear trailing arms that move the shocks forward, allowing a larger window for shock tuning and providing improved weight bias. The trailing arms are paired with a rear anti-roll bar for a more stable and consistent suspension when crawling on the rocks. An adjustable aluminum track bar mount firmly bolted to the chassis rail gives the Enduro GK more reliable and responsive steering without the flex. Our shock mount inserts with multiple mounting positions allow for precise suspension tuning, whether it's moving the shocks up, down, forward, or back.

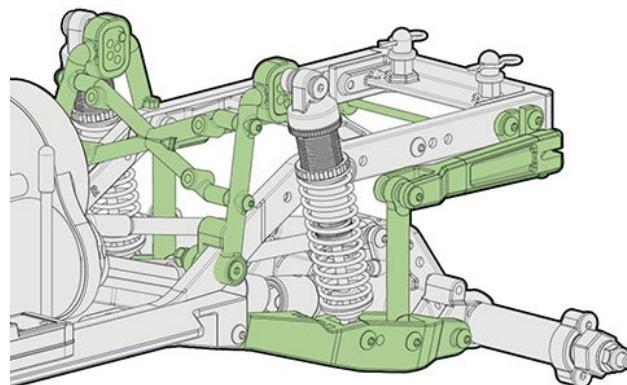

GKS trailing arms in green

The **#40111C LiPo Combo** includes a #27201 Reedy Compact Balance Charger and #758 Reedy 7.4V 2S LiPo Battery with T-plug.

The performance doesn't stop there. The Enduro GK is built on our proven stamped steel C-channel Enduro chassis and retains the same awesome features as before.

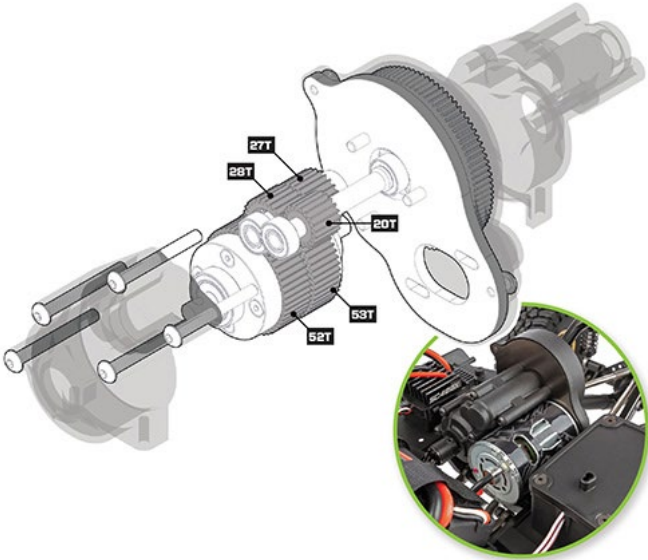

The behind-the-axle (BTA) steering link greatly improves approach angle and front-end clearance, making rough terrain much easier to handle. The Stealth® X features the ability to adjust the rear drive ratio independently of the front drive across three levels: stock overdrives the front end 5.7% (installed in RTR), option 1 provides a one-to-one drive ratio front-to-rear (available separately), and option 2 overdrives the front end 11.83% (included with RTR).

Feeding the power to the tires are 3-piece telescopic driveshafts with an extruded aluminum center section, universal front drive axles, and hardened steel ring and pinion gears. With the Enduro GK drivetrain, delivering useful and reliable power will not be an issue.

The Enduro Gatekeeper Rock Crawler Buggy RTR isn't just all about performance, it's got looks, too. With inspired styling from competition off road vehicles, the Enduro GK looks awesome tackling the terrain.

The new Gatekeeper buggy body comes equipped with a multi-piece injection-molded cage to replicate those found on full-size crawlers. The polycarbonate body panels are screen printed with the Element RC livery and are detailed with high-quality decals. Also included is an interior panel with injection-molded driver and passenger heads, along with detailed decals for gauge cluster, center console, navigation and body suits. The looks don't stop there. Located in the back of the Gatekeeper body are a black, paintable, injection-molded radiator with cooling fans and detailed racing fuel cell. With all these cool scale details, the Gatekeeper caged body looks awesome on the trail.



Having a caged body may seem to make working on the GK chassis difficult, but that's not the case. The removable hinged body mount allows the whole body to swing forward, granting access to the entire chassis and electronics. This makes working on the chassis a breeze, whether out on the trail or in the garage.

Officially Licensed Wheels and Tires: Gripping the trail is a set of officially licensed General Grabber™ X3 tires molded in a high-performance, soft compound rubber. The General Grabber™ X3 tires are mounted on officially licensed Method 701 Trail Series beadlock wheels. No more worrying if your RTR tires will come unglued.

The combination of industry leading General Tires™ and Method Wheels make the Enduro Gatekeeper look and perform great.

HIGHLIGHTS



ENDURO

WITH TRAILING ARM SUSPENSION



Rear Anti-roll Bar: The rear anti-roll bar helps keep the rear suspension stable while driving over rough terrain and improves climbability on steep inclines or side hills.



Shock Mount Inserts: GKS shock mount inserts provide drivers with the ability to tune shock angle, droop and vehicle ride height without affecting spring preload.

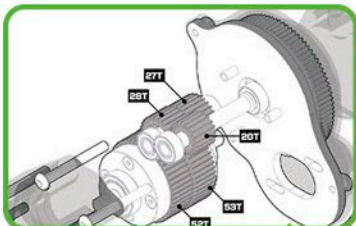

Stealth X Transmission: Our transmission features the ability to adjust the rear drive ratio independently of the front drive in 3 levels: stock overdrives the front 5.7%, option 1 (not included) is a one-to-one drive ratio and option 2 overdrives the front 11.83%.



Reedy Power Crawler Motor: The Reedy Power 5-slot 14-turn brushed 550 crawler motor provides ample torque with a smooth power delivery. This allows for slow precise acceleration while maintaining consistent power over rough terrain and obstacles.



Reedy Power Electronic Speed Controller: The water-resistant SC480X brushed ESC is specifically programmed for crawling with proportional forward/reverse, dual auxiliary power output leads, LiPo low-voltage cutoff protections, and T-plug connector.



Aluminum Track Bar Mount: The GKS package includes an aluminum track bar mount bolted directly to the steel frame rail, making the front suspension more rigid and flex-free with a more precise steering feel.

Due to ongoing R&D, photos may not match final kit.

MORE FEATURES

- Behind-the-axle (BTA) steering
- Aluminum steering plates
- CMS (Chassis Mounted Steering)
- Steel 25T servo horn
- Integrated servo winch mount
- Threaded aluminum shock bodies
- Stamped steel frame rails
- Aluminum motor plate
- Optimized ball cups for more fluid axle articulation
- Telescopic driveshafts front and rear
- Extruded aluminum driveshaft splines
- One-piece rear axle design
- Splined front axle with adjustable caster
- Universal front drive axles
- Machined input pinion gear
- Metal ring gear
- Machined steel top shaft
- Heavy duty 5mm diameter steel links
- Metal ball bearings
- Adjustable front track bar

SPECIFICATIONS

Scale	1:10
Power	Electric
Length	18.38" (467mm)
Width	9.75" (248mm)
Weight	varies
Wheelbase	325mm (12.8")
Transmission Ratio	varies

ITEMS NEEDED TO COMPLETE

- **#40111:** One 2-cell or 3-cell shorty LiPo battery pack (#758 WolfPack LiPo 3000mAh 30C 7.4V or #759 WolfPack LiPo 3000mAh 30C 11.1V)
- **#40111:** Battery charger (#27201 Reedy 324-S Compact Balance Charger)
- **#40111, 40111C:** (Optional: #27034 Reedy SC480X Program Card for fine-tuning the ESC.)

Watch the GK Kit Video!

<https://youtu.be/4pZHJDf0G-w>



CATALOG INFORMATION

UPC	Part No.	Description	MAP	MSRP	Available
784695401112	40111	Enduro Gatekeeper Rock Crawler Buggy RTR	\$399.99	\$585.99	November 2020
784695984165	40111C	Enduro Gatekeeper Rock Crawler Buggy RTR LiPo Combo	\$449.99	\$659.99	November 2020

Download all zipped photos here : <https://bit.ly/2ligRys> (11.3 MB). Link is active for 30 days.



21062 Bake Pkwy
Lake Forest CA 92630
www.AssociatedElectrics.com

