

### Front Suspension:

Ride Height: \_\_\_\_\_  
 Camber: \_\_\_\_\_  
 Toe: \_\_\_\_\_  
 Arm Type: \_\_\_\_\_  
 Tower Type: \_\_\_\_\_  
 Wheel Hex Width: \_\_\_\_\_  
 Steering Block: \_\_\_\_\_  
 Bulkhead Type: \_\_\_\_\_  
 Kick-Up Angle: \_\_\_\_\_  
 Notes: \_\_\_\_\_  
 \_\_\_\_\_  
 \_\_\_\_\_

Bump Steer Spacing: \_\_\_\_\_

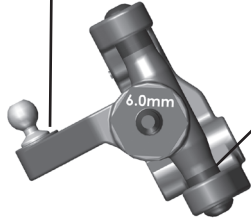

Axle Height:

+3   
 +2   
 +1   
 0

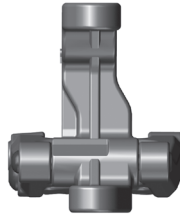

Ball Stud Spacing: \_\_\_\_\_

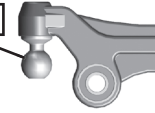

Ball Stud Spacing: \_\_\_\_\_

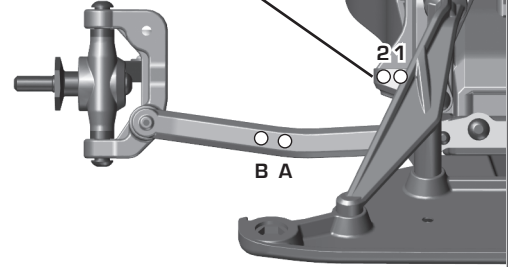

### Rear Suspension:

Ride Height: \_\_\_\_\_  
 Camber: \_\_\_\_\_  
 Toe: \_\_\_\_\_  
 Anti-Roll Bar: Yes  No   
 Arm Type: \_\_\_\_\_  
 Wheel Hex Width: \_\_\_\_\_  
 Notes: \_\_\_\_\_  
 \_\_\_\_\_  
 \_\_\_\_\_

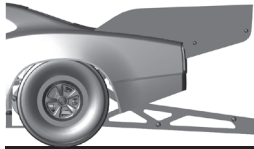
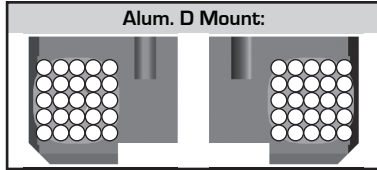
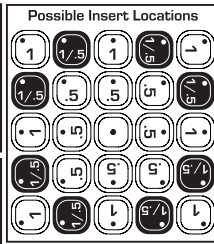
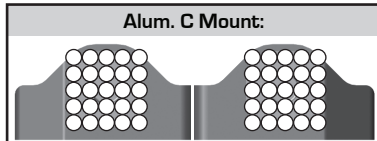

Distance From Ground: \_\_\_\_\_

Ball Stud Spacing: \_\_\_\_\_

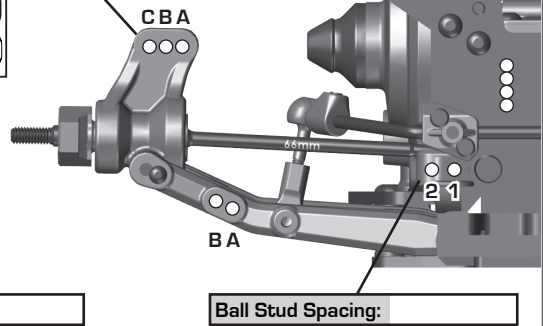

Ball Stud Spacing: \_\_\_\_\_

### Electronics:

Radio: \_\_\_\_\_ Servo: \_\_\_\_\_  
 EPA: Throttle: \_\_\_\_\_ % Brake: \_\_\_\_\_ %  
 ESC: \_\_\_\_\_  
 ESC Settings: \_\_\_\_\_  
 Motor: \_\_\_\_\_  
 Wind: \_\_\_\_\_ Timing: \_\_\_\_\_  
 Pinion: \_\_\_\_\_ Spur: \_\_\_\_\_  
 Battery: \_\_\_\_\_  
 Battery Position: \_\_\_\_\_  
 Battery Weight: \_\_\_\_\_

### Drivetrain:

Differential Setting: \_\_\_\_\_  
 Diff Fluid: \_\_\_\_\_  
 Notes: \_\_\_\_\_  
**Slipper Clutch:**  
 Type: \_\_\_\_\_  
 # of Pads: \_\_\_\_\_  
 Setting: \_\_\_\_\_  
  
 Notes: \_\_\_\_\_

### Shocks:

	Front	Rear
Piston:	_____	_____
Fluid:	_____	_____
Spring:	_____	_____
Limiters:	Int: _____ Ext: _____	Int: _____ Ext: _____
Stroke:	_____	_____
Eyelet Length:	_____	_____
Cup Offset:	_____	_____
Notes:	_____	

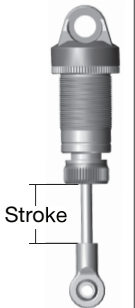

### Track Info:

Burnout: Yes  No  Length: \_\_\_\_\_  
 Burnout Surface: \_\_\_\_\_  
 Surface: Asphalt  Concrete  Prep  No-Prep   
 Traction: Low  Medium  High  Very High   
 Temperature: Ambient: \_\_\_\_\_ Track: \_\_\_\_\_  
 Tire Warmers: Yes  No  Time: \_\_\_\_\_ Temp: \_\_\_\_\_  
 Notes: \_\_\_\_\_  
 \_\_\_\_\_  
 Vehicle Comments: \_\_\_\_\_

### Tires:

Front Tires: \_\_\_\_\_  
 Front Compound: \_\_\_\_\_  
 Front Insert: \_\_\_\_\_  
 Rear Tires: \_\_\_\_\_  
 Rear Compound: \_\_\_\_\_  
 Rear Insert: \_\_\_\_\_  
 Wheel (F/R): \_\_\_\_\_  
 Notes: \_\_\_\_\_

### Body, Weight:

Body: \_\_\_\_\_  
 Body Notes: \_\_\_\_\_  
 Chassis Weights: \_\_\_\_\_  
 Chassis Notes: \_\_\_\_\_  
 Vehicle Weight: Front: \_\_\_\_\_ Rear: \_\_\_\_\_  
 Total Vehicle Weight: \_\_\_\_\_  
 Notes: \_\_\_\_\_