

## Front Suspension:

Ride Height: \_\_\_\_\_  
 Camber: \_\_\_\_\_  
 Toe: \_\_\_\_\_  
 Arm Spacing: \_\_\_\_\_  
 Tower Type: \_\_\_\_\_  
 Wheel Hex: \_\_\_\_\_  
 Steering Block KPI: \_\_\_\_\_  
 Caster Block Spacing: \_\_\_\_\_  
 Notes: \_\_\_\_\_  
 \_\_\_\_\_  
 \_\_\_\_\_  
 \_\_\_\_\_  
 \_\_\_\_\_

Upper Arm Insert: 

Steering Bellcrank Position: Up  Down

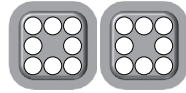
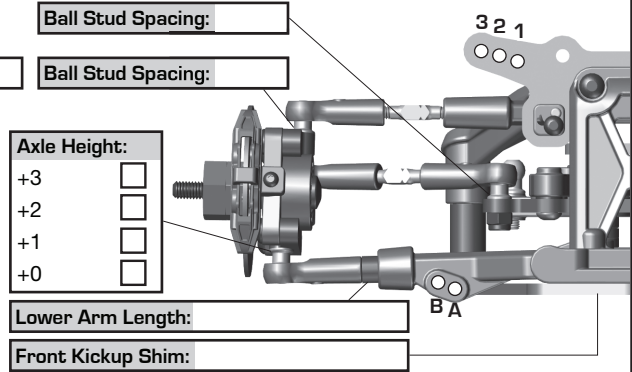
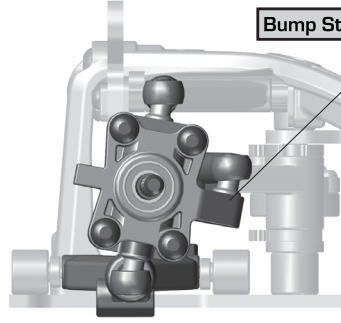
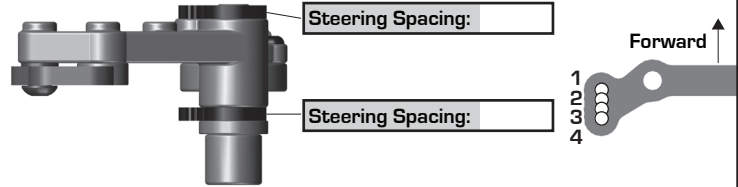

## Rear Suspension:

Ride Height: \_\_\_\_\_  
 Camber: \_\_\_\_\_  
 Arm Spacing: \_\_\_\_\_  
 Tower Type: \_\_\_\_\_  
 Wheel Hex: \_\_\_\_\_  
 Hub Spacing: \_\_\_\_\_  
 Notes: \_\_\_\_\_  
 \_\_\_\_\_  
 \_\_\_\_\_  
 \_\_\_\_\_  
 \_\_\_\_\_

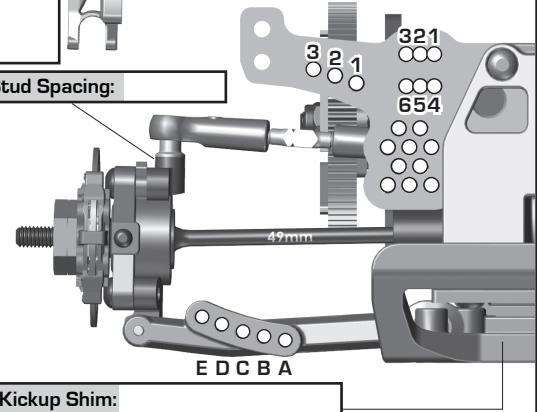
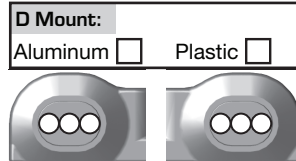
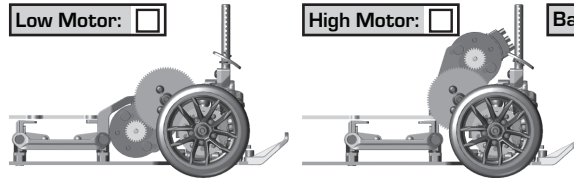
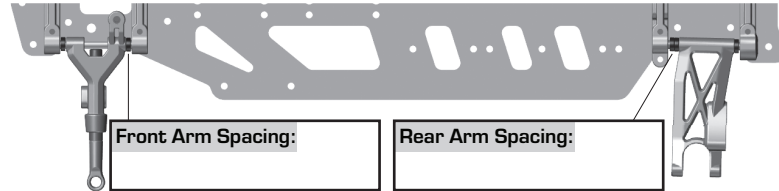

## Electronics:

Radio: \_\_\_\_\_  
 Servo: \_\_\_\_\_  
 EPA: Throttle: \_\_\_\_\_ % Brake: \_\_\_\_\_ %  
 ESC: \_\_\_\_\_  
 ESC Settings: \_\_\_\_\_  
 Motor / Wind: \_\_\_\_\_ Timing: \_\_\_\_\_  
 Pinion: \_\_\_\_\_ Spur: \_\_\_\_\_  
 Motor Position: \_\_\_\_\_  
 Battery: \_\_\_\_\_ Weight: \_\_\_\_\_  
 Battery Position: Fwd:  Back:  High:  Low:  Other:   
 Notes: \_\_\_\_\_  
 Gyro: \_\_\_\_\_  
 Gyro Settings: \_\_\_\_\_  
 Gyro Mode: \_\_\_\_\_  
 Limit Gain: \_\_\_\_\_  
 Notes: \_\_\_\_\_

## Drivetrain:

Differential: \_\_\_\_\_ Ball Diff:   
 Gear Diff:  Gear Diff Locked:   
 Diff Setting: \_\_\_\_\_  
 Notes: \_\_\_\_\_

## Tires:

Front Tires: \_\_\_\_\_  
 Front Compound: \_\_\_\_\_  
 Rear Tires: \_\_\_\_\_  
 Rear Compound: \_\_\_\_\_  
 Wheel (F/R): \_\_\_\_\_  
 Notes: \_\_\_\_\_

## Body, Chassis, Weight:

Body: \_\_\_\_\_  
 Rear Wing: \_\_\_\_\_  
 Chassis Type: \_\_\_\_\_  
 Chassis Weights: \_\_\_\_\_  
 Total Vehicle Weight: \_\_\_\_\_

## Shocks:

	Front	Rear
Piston:	_____	_____
Thickness:	_____	_____
Fluid:	_____	_____
Spring:	_____	_____
Limiters: Int: _____ Ext: _____ Int: _____ Ext: _____		
Stroke:	_____	_____
Shock Length:	_____	_____
Eyelet Length: 0 <input type="checkbox"/> +3 <input type="checkbox"/> +6 <input type="checkbox"/> 0 <input type="checkbox"/> +3 <input type="checkbox"/> +6 <input type="checkbox"/>		
Alum. Bodies: <input type="checkbox"/> Chrome Shafts: <input type="checkbox"/> Machined Spacers: <input type="checkbox"/>		
Notes: _____		



Stroke

## Vehicle Comments:

Notes: \_\_\_\_\_  
 \_\_\_\_\_  
 \_\_\_\_\_  
 \_\_\_\_\_