

# DC10

1:10 RWD COMPETITION DRIFT KIT



#30134 DC10 Drift Car Kit



1:10 Scale RWD Electric On Road Competition Drift Car Kit Manual



CHAMPIONS *by* DESIGN

[TeamAssociated.com](http://TeamAssociated.com)

# TEAM ASSOCIATED

## ⚡ Introduction

Thank you for purchasing this Team Associated product. This assembly manual contains instructions and tips for building and maintaining your new vehicle. Please take a moment to read through the manual and familiarize yourself with the steps. We are continually changing and improving our designs; therefore, actual parts may appear slightly different than the illustrations. New parts will be noted on supplementary sheets located in the appropriate parts bags.

Check each bag for these sheets before you start to build.

Check [www.rc10.com](http://www.rc10.com) for the latest versions of our instruction manuals.

## ⚡ DC10 Kit Features

Since 1964, Team Associated has proven to be the leader in competition racing. And with its roots in on-road racing, it makes sense that our Area 51 engineers would develop the ultimate RC drift car, the DC10. In RC drifting, vehicle balance is key. With the many suspension and chassis tuning options of the DC10, drivers can setup their car with precision. From camber, caster, and kingpin inclination (KPI) to motor and battery position, the Team Associated DC10 1:10 Scale RWD Competition Drift Kit has it all!

- Adjustable wheel hexes allow the track width to accommodate a wide variety of body and wheel combinations.
- A convenient quick-release battery box gets you back into the door-to-door tandem action.
- With camber, caster, toe-in, KPI, and more, there are many suspension tuning options.
- The motor position can be mounted high, and battery moved back for more rear weight bias.
- Our race-proven threaded aluminum oil-filled shocks make transitions smooth and reliable.
- Dual servo mounting locations on the carbon fiber upper deck for the perfect weight balance.
- +6mm transmission height adjustment insert allows for higher roll center and larger spur gear capabilities.
- Maximum steering throw provides superior control through drifting turns

## ⚡ Additional

Your new DC10 Kit comes unassembled and requires the following items for completion (refer to [AssociatedElectrics.com](http://AssociatedElectrics.com) for suggestions):

- RC 2-channel surface frequency radio system
- AA-size batteries for transmitter
- Electronic Speed Control ("ESC")
- Steering servo
- RC electric motor
- Pinion gear, size determined by type/turn or kV of motor
- Battery charger (a peak detection charger, or LiPo compatible charger)
- 2-cell LiPo battery pack
- 1:10 Drift Body
- Polycarbonate specific spray paint
- Cyanoacrylate glue ("CA") (#1697)
- Thread locking compound (#1596)
- Tires and Inserts, Fronts and Rears

## ⚡ Other Helpful Items

- Silicone Shock Fluid (Refer to [AssociatedElectrics.com](http://AssociatedElectrics.com) for complete listings)
- FT Body Scissors (#1737)
- FT Hex/Nut Wrenches (#1519)
- FT Universal Tire Balancer (#1498)
- FT Dual Turnbuckle Wrench (#1114)
- FT Body Reamer (#1499)
- Needle Nose Pliers
- Calipers or a Precision Ruler
- Green Slime shock lube (#1105)
- Shock Pliers (#1681)
- FT Ballcup Wrench (#1579)
- Soldering Iron
- Wire Cutters
- Hobby Knife









Associated Electrics, Inc.  
21062 Bake Parkway.  
Lake Forest, CA 92630







Customer Service  
Tel: 949.544.7500  
Fax: 949.544.7501

**Hardware - 1:1 Scale View**



**Button Head (bhcs)**

	2x4mm (31510)
	2x6mm (4672)
	2.5x4mm (4673)
	3x6mm (31531)
	3x8mm (31532)
	3x10mm (25211)
	3x12mm (89202)
	3x30mm (91478)

**Flat Head (fhcs)**

	3x8mm (25201)
	3x10mm (25202)
	3x16mm (25204)
	3x20mm (89210)

**Ball Bearings**

	5x8x2.5mm (8680)
	5x10x4mm (91560)
	10x15x4 (91563)



**Cap Head (shcs)**

	3x45mm (89279)
--	----------------

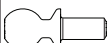

**Set Screws**

	3x8mm (4670)
	4x5mm (25226)





**Ballstuds**

	HD 6mm (91047)
	Ti HD 6mm (91751)
	HD 8mm (91048)
	Ti HD 8mm (91752)

**LP Socket Head (lp shcs)**

	3x6mm (41089)
	3x10mm (41090)
	3x22mm (41095)

**Shims and Washers**

	5.5x0.5mm (31381)
	5.5x1.0mm (31382)
	5.5x2.0mm (31383)
	3x8mm Washer (89218)

**Nuts (lock/plain)**

	M3 Nut (91477)
	M3 Alum. Locknut, Blue (31550)
	M3 Locknut, Black (25215)
	M4 Locknuts:
	Serrated Steel LP (91150)
	Serrated Steel (Silver) (91826)
	FT Aluminum (Blue) (31551)
	Serrated Aluminum (Black) (91738)

**Notes:**

**Table of Contents**

1.....	Cover	17.....	Shocks Build Bag 8
2.....	Introduction	19.....	Misc. Build
3.....	1:1 Hardware “Fold Out”	20.....	Optional High Motor Build
4.....	Table of Contents	23.....	Optional Spool Build
5.....	Chassis / Suspension / Bumper Build Bag 1	23.....	Tuning Tips
7.....	Steering Build Bag 2	24.....	Notes
10.....	Gear Differential Build Bag 3 and 9	26.....	Back Cover
11.....	Gearbox Build Bag 4		
12.....	Battery Tray Build Bag 5		
14.....	Front and Rear Hubs Build Bag 6		
16.....	Turnbuckles Build Bag 7		

**Notes**



This symbol indicates a special note or instruction in the manual.



This symbol indicates the number of the same part that is required.



This symbol indicates the order within a step to assemble parts.



This symbol indicates there are optional FT parts available



This symbol indicates a Racers Tip.



This symbol indicates where Thread Lock Adhesive should be applied. \*not included

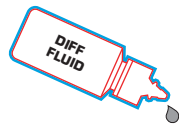

This symbol indicates where Diff Fluid should be applied.

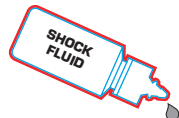

This symbol indicates where Shock Fluid should be applied.



This symbol indicates where FT Silicone Grease should be applied. \*not included

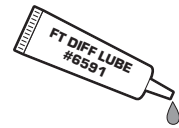

This symbol indicates where FT Diff Lube should be applied. \*not included



This symbol indicates where Black Grease should be applied.



This symbol indicates where Green Slime can be applied. \*not included



There is a 1:1 hardware foldout page in the front of the manual. To check the size of a part, line up your hardware with the correct drawing until you find the exact size. Each part in the foldout has a number assigned to it for ordering replacement parts.

**:: Bag 1 - Step 1**

LEFT SIDE

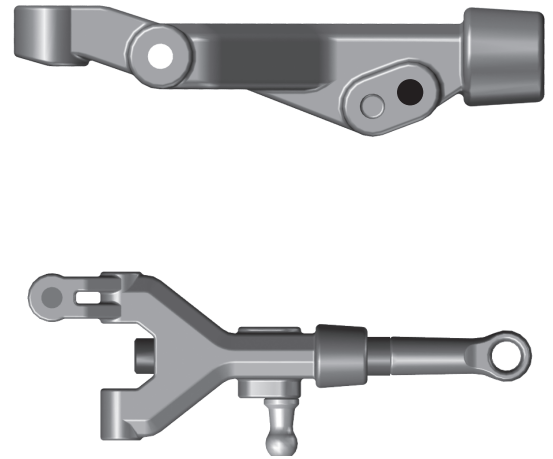
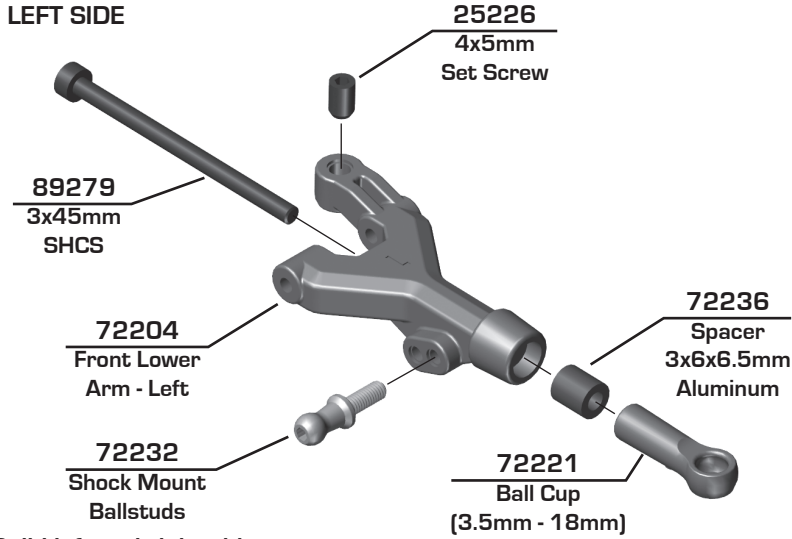

Build left and right sides

**:: Bag 1 - Step 2**

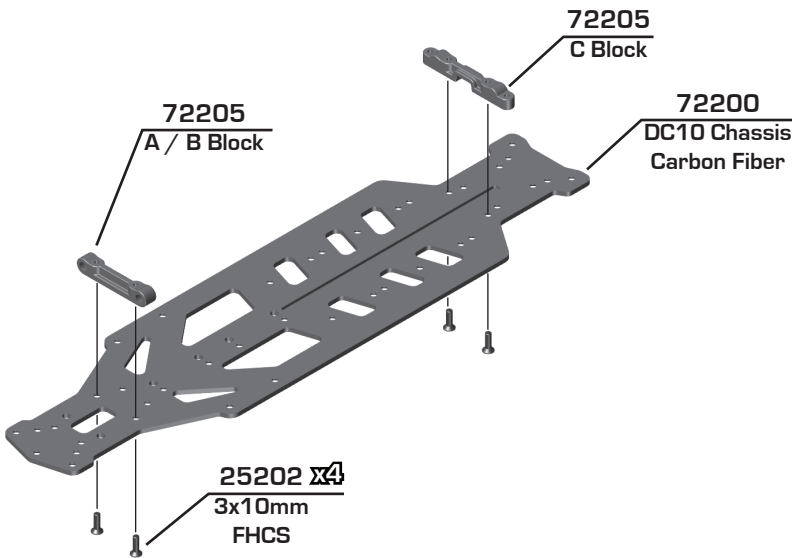

You have the option of using standard 2mm washers or 2mm clips for the inner hinge pins and front / rear arm adjustments

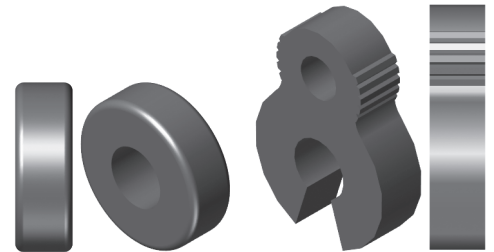

**:: Bag 1 - Step 3**



Factory recommended settings for wheelbase:

Front Arms: Middle  
(2mm spacers front and 2mm spacers rear)

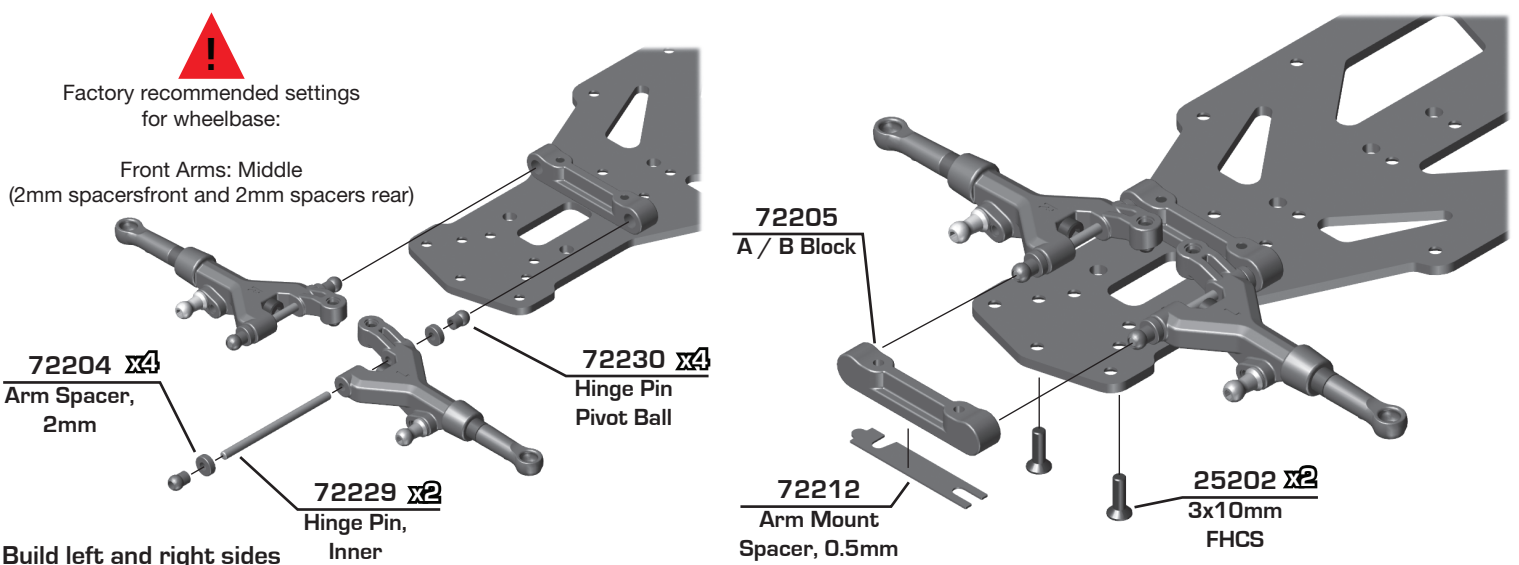

Build left and right sides

**Bag 1 - Step 4**

LEFT SIDE

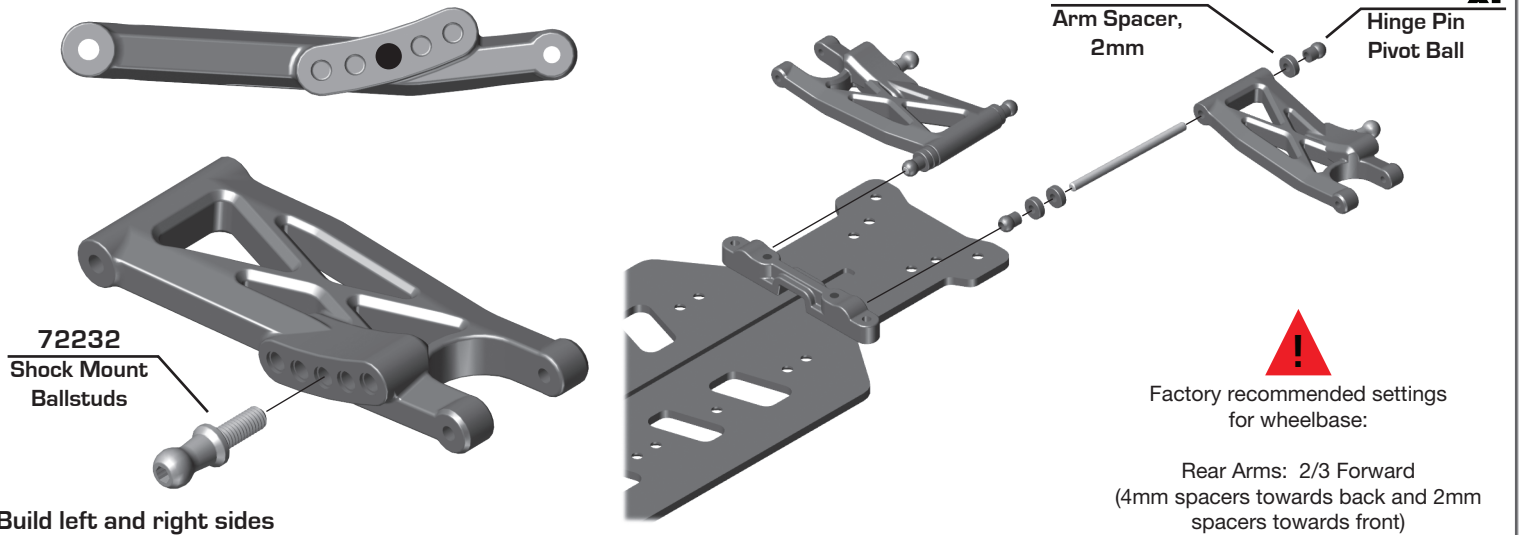

Build left and right sides

**Bag 1 - Step 5**

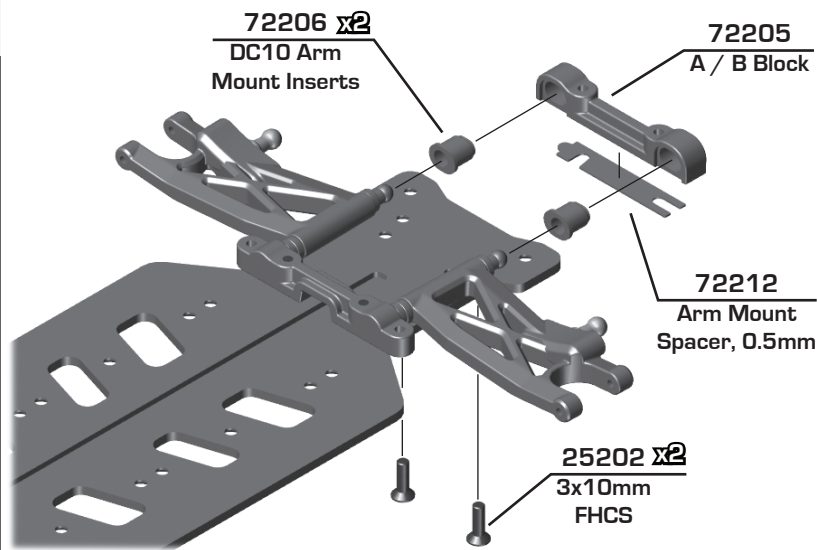

Factory Rear Toe Setting:  
1.0 degree - arrow inward.

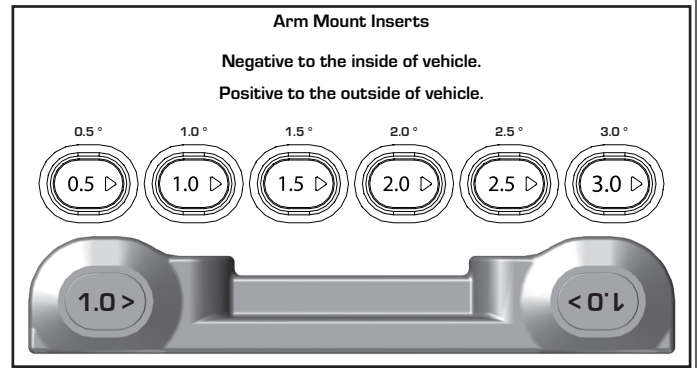

**Bag 1 - Step 6**

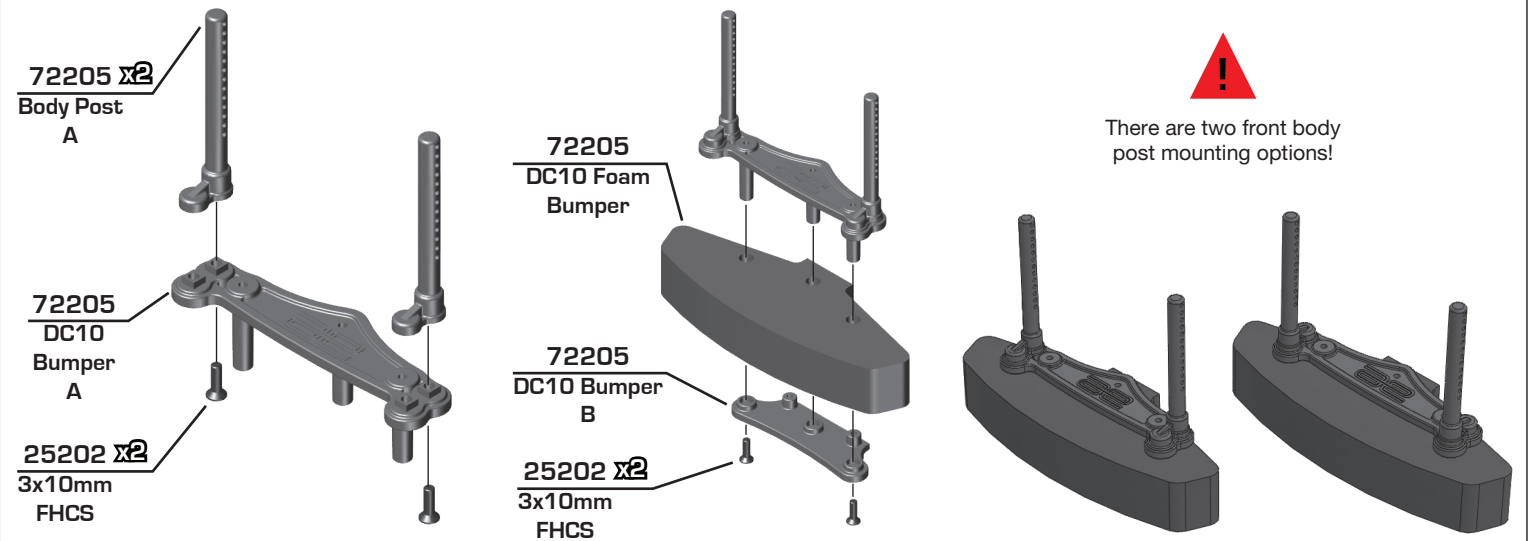

There are two front body post mounting options!

**:: Bag 1 - Step 7**

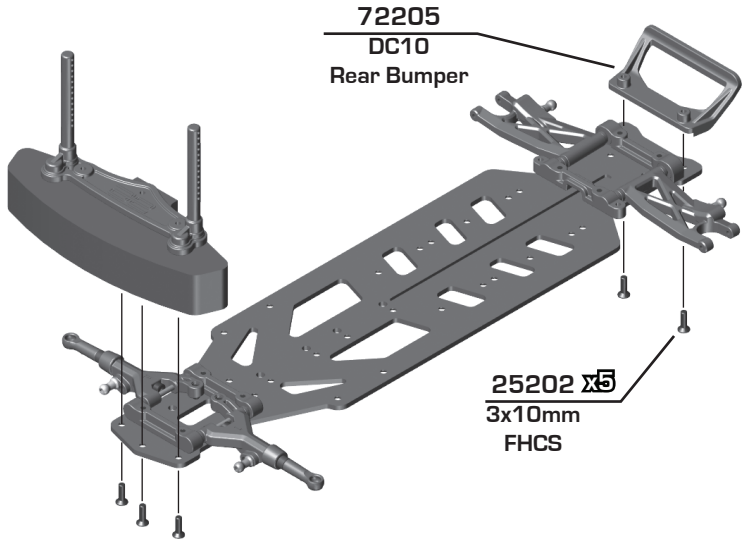

**:: Bag 2 - Step 1**

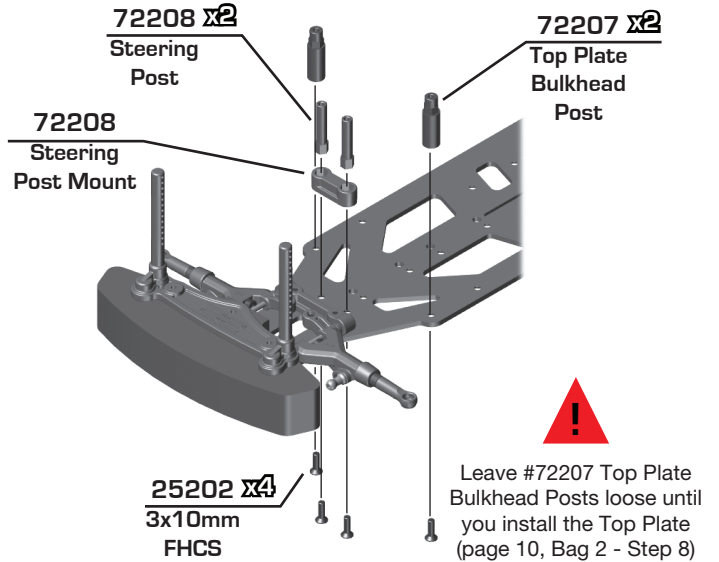

**:: Bag 2 - Step 2**

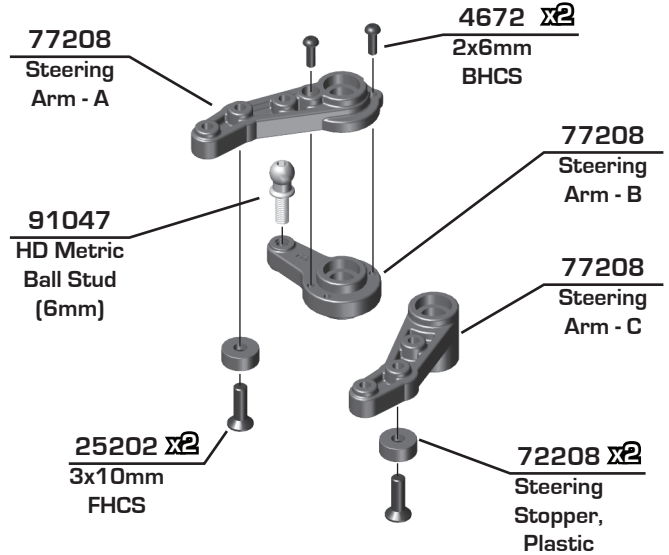
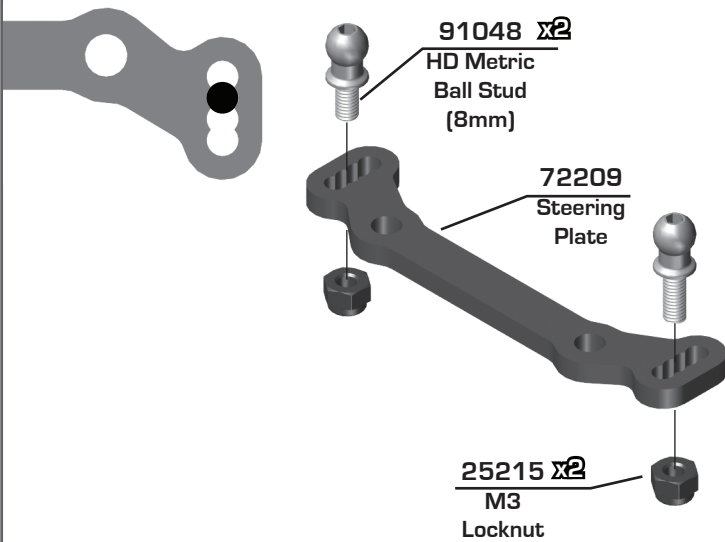

**:: Bag 2 - Step 3**

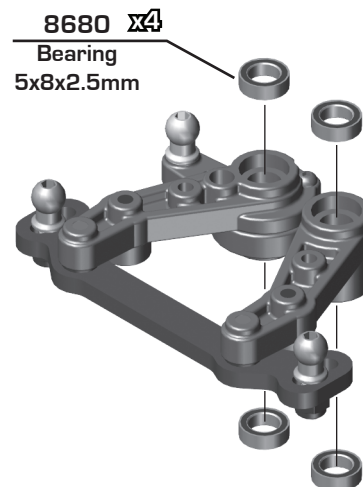
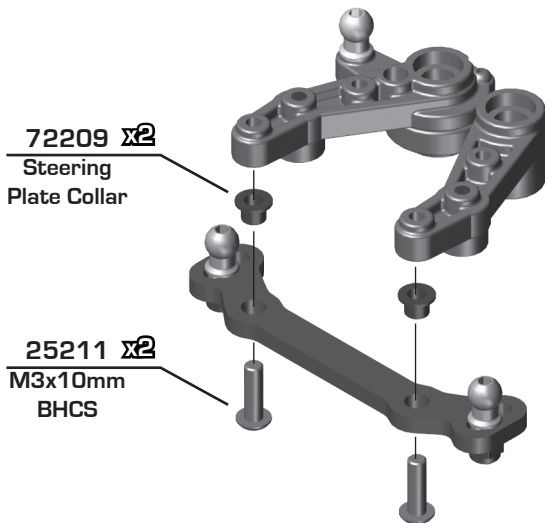

Bag 2 - Step 4

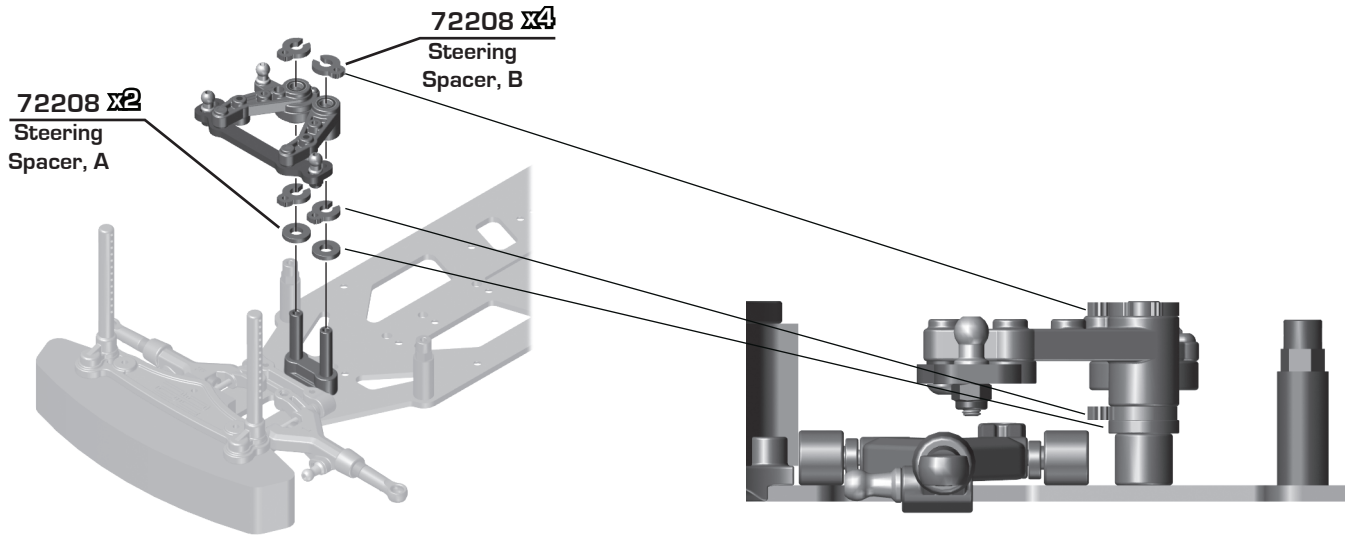

Bag 2 - Step 5

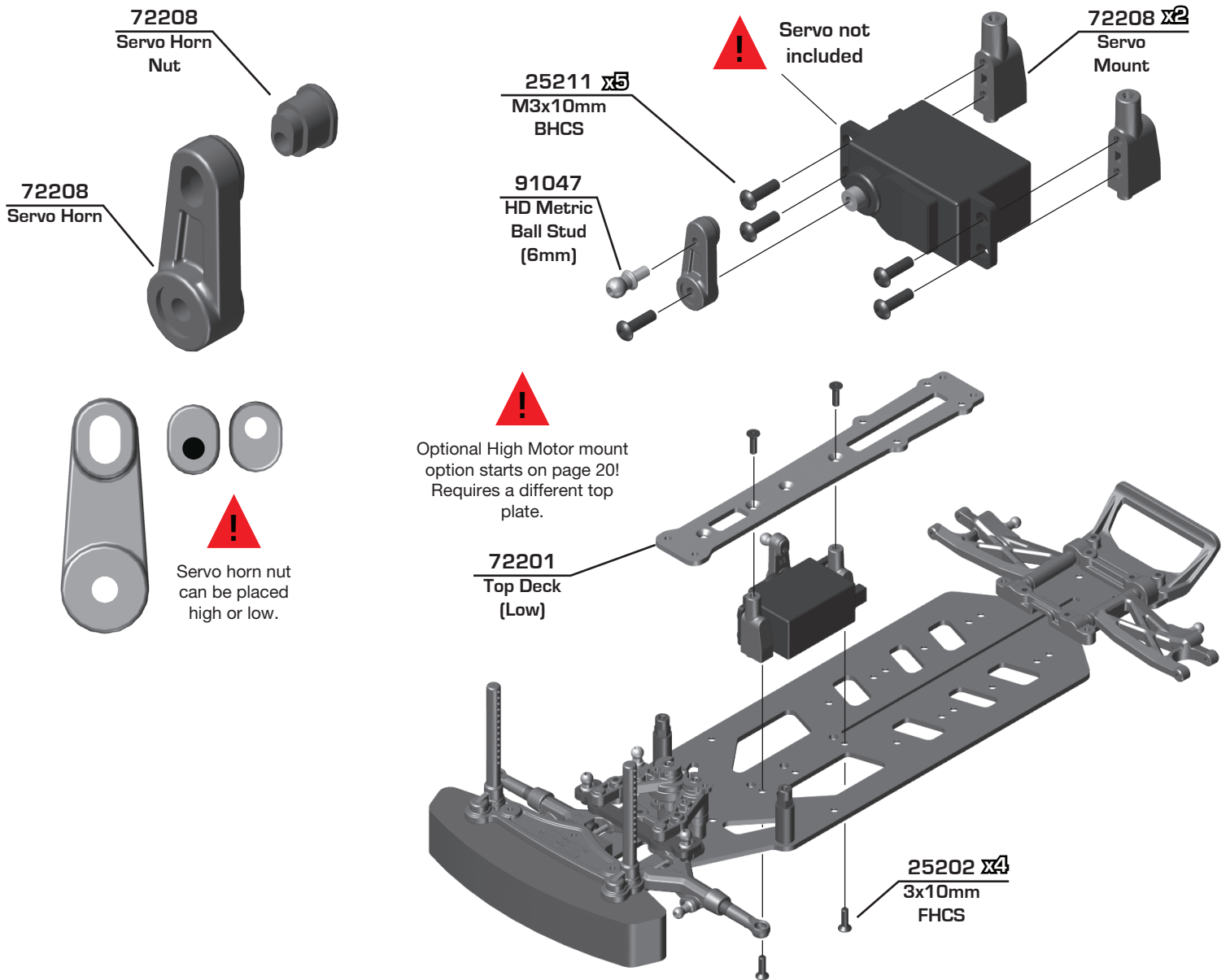



**:: Bag 1 and 2 - Step 6**

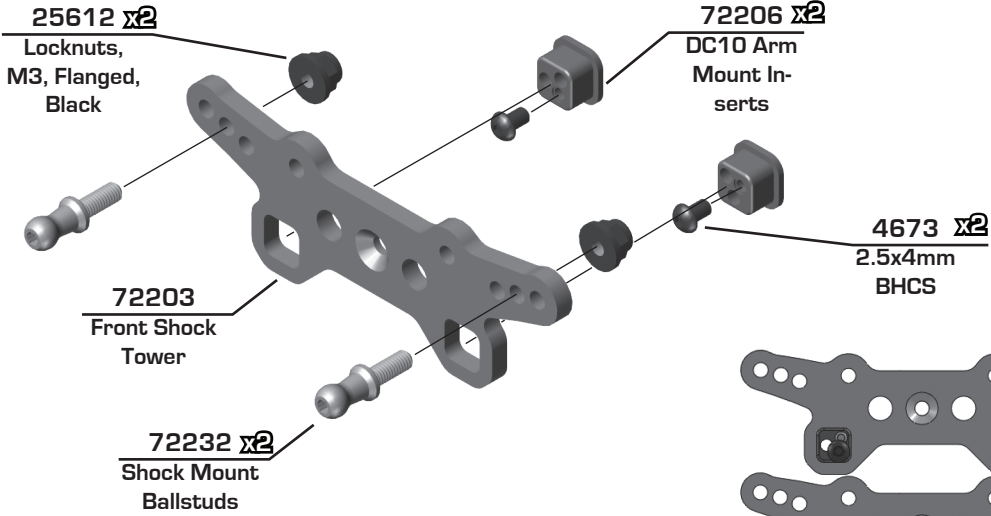

**Front Upper Arm Roll Center Adjustment:**

This is for roll center and track width. The lower the roll center the more stable the car is. The higher the roll center the more reactive the car is. There are no degree settings here, just roll center adjustment.

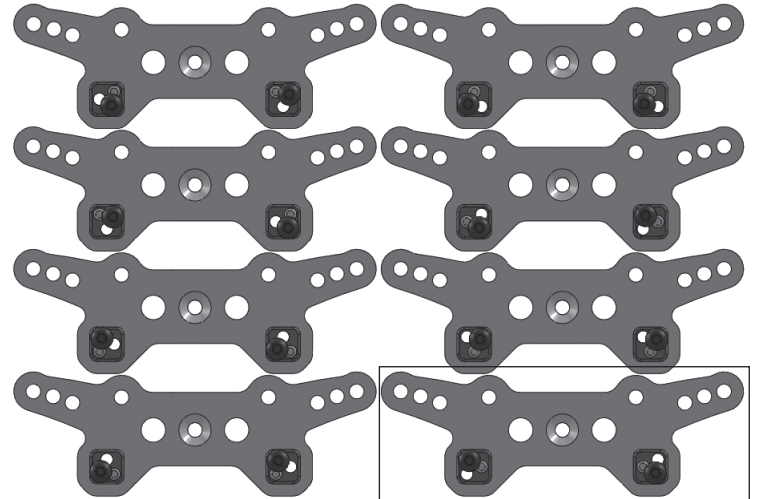

**Factory Setting:**

**:: Bag 1 and 2 - Step 7**

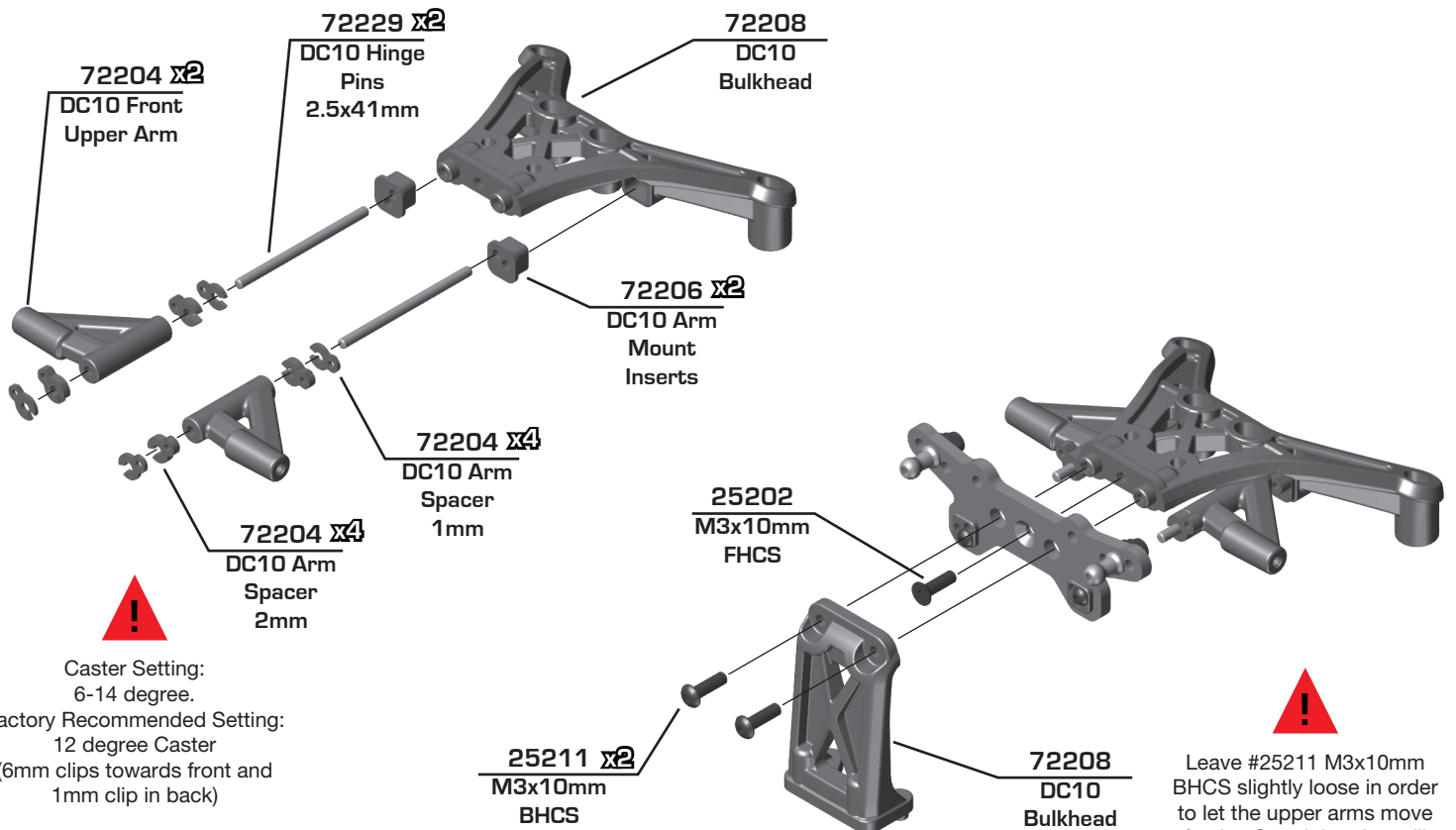

**Caster Setting:**  
6-14 degree.  
**Factory Recommended Setting:**  
12 degree Caster  
(6mm clips towards front and 1mm clip in back)



Leave #25211 M3x10mm BHCS slightly loose in order to let the upper arms move freely. Overtightening will create bind in the arms.

Bag 2 - Step 8

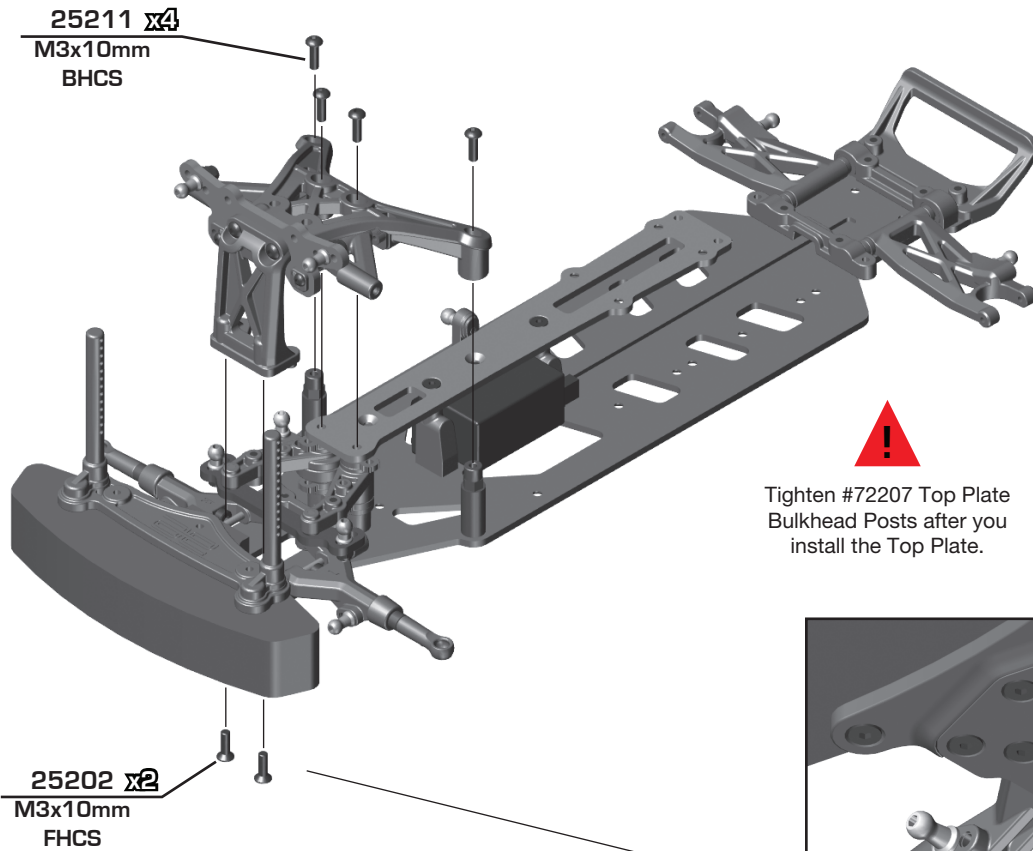

Tighten #72207 Top Plate Bulkhead Posts after you install the Top Plate.

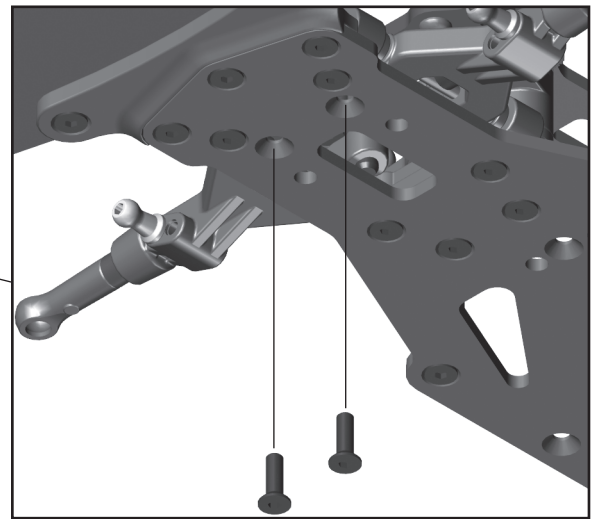

Bag 3 and 9 - Step 1

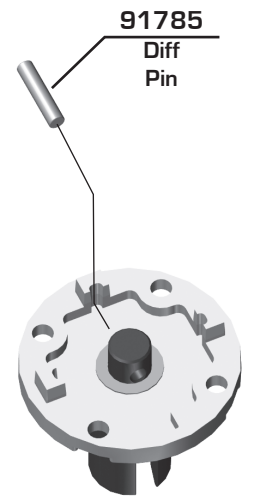
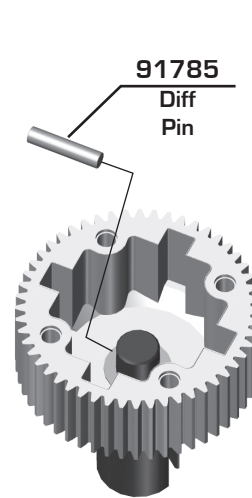
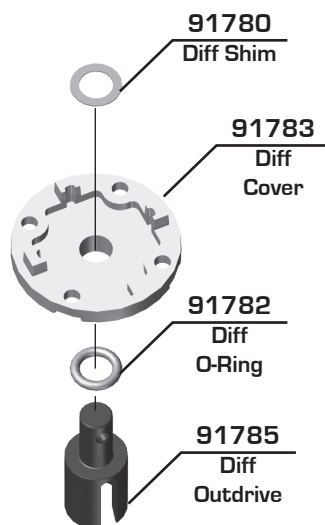
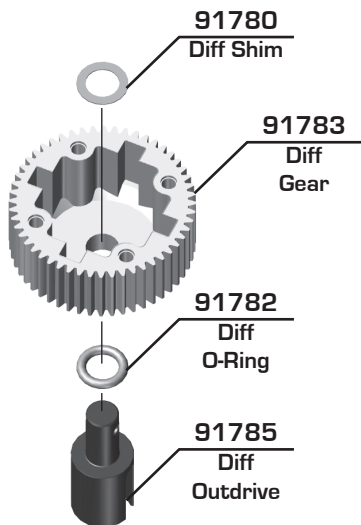

Bag 3 and 9 - Step 2

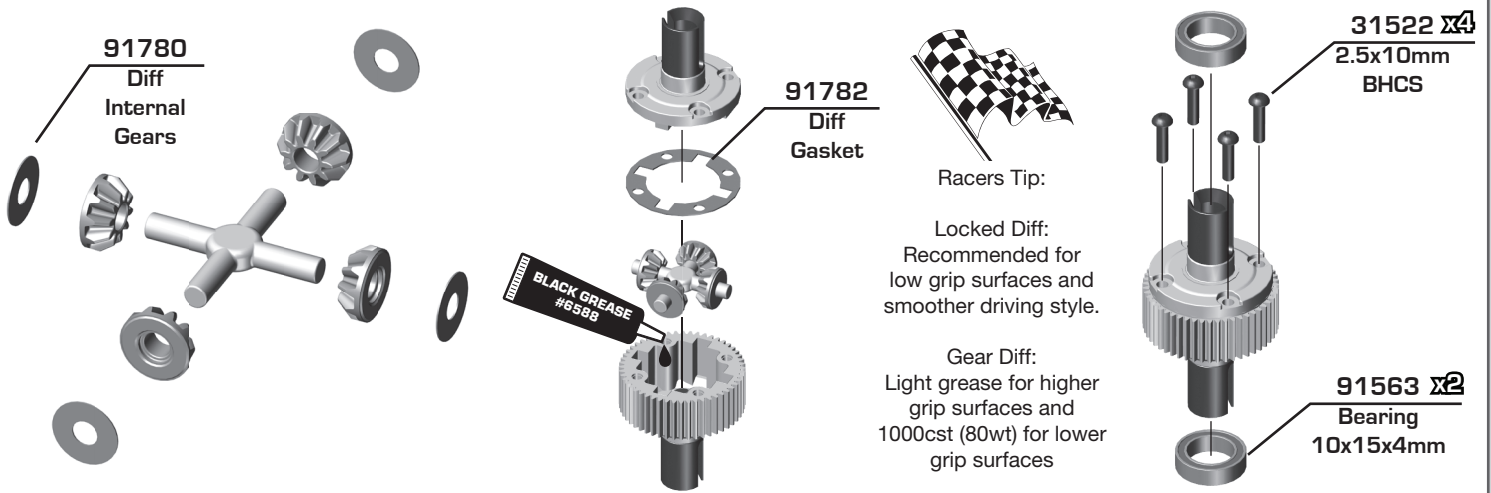

Bag 4 - Step 1

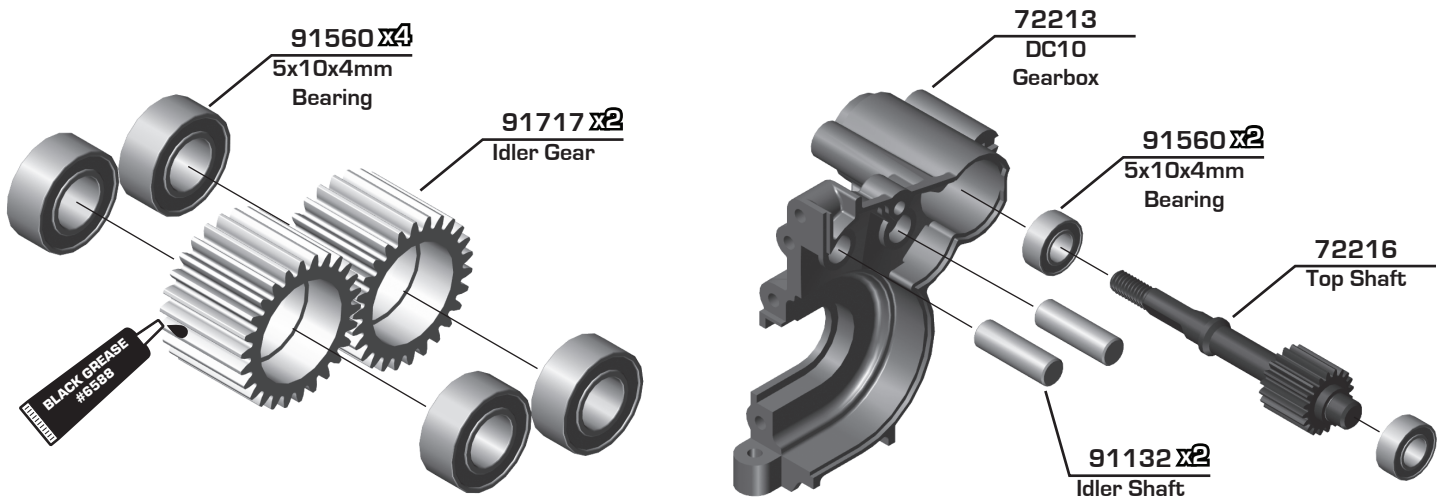

Bag 4 - Step 2

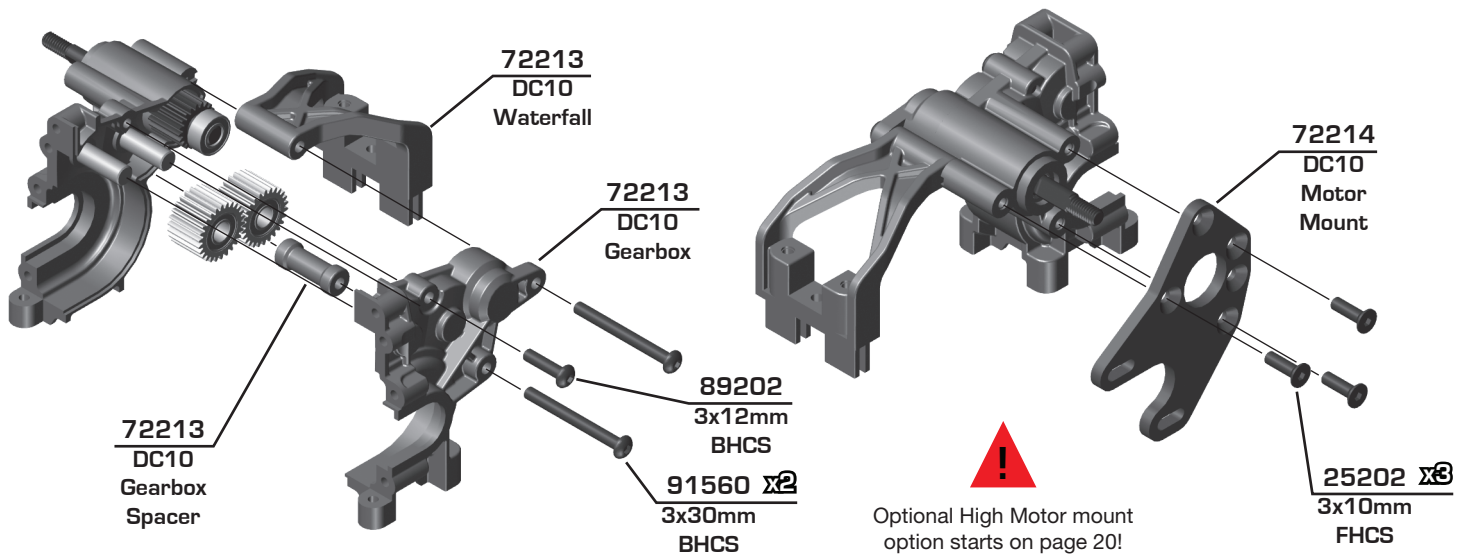

Bag 4 - Step 3

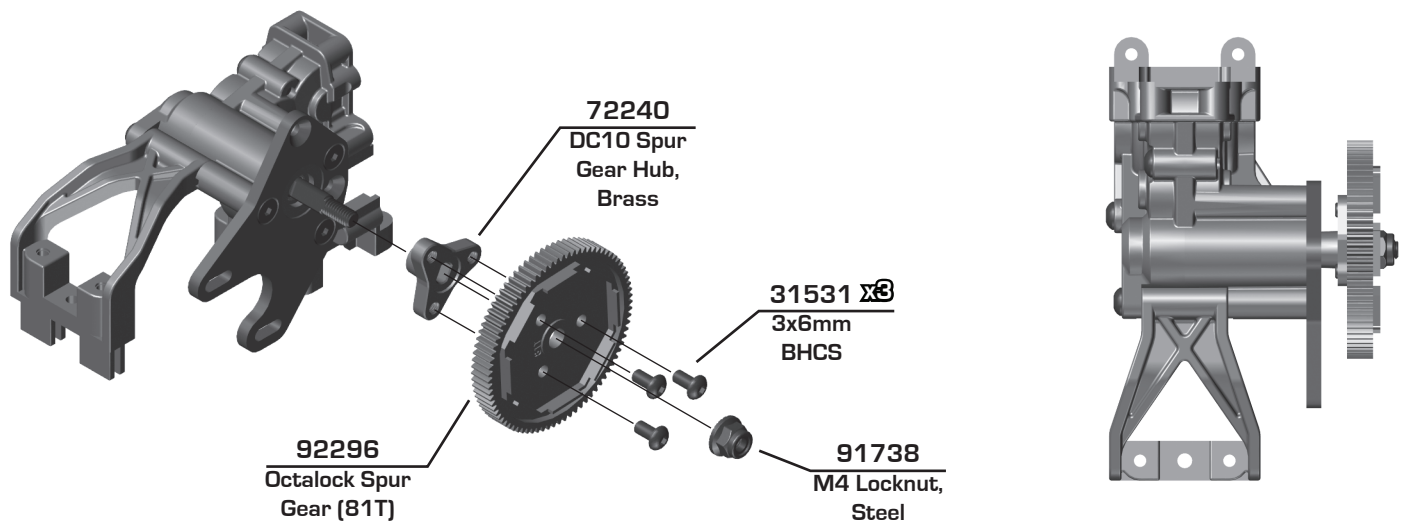

Bag 4 - Step 4

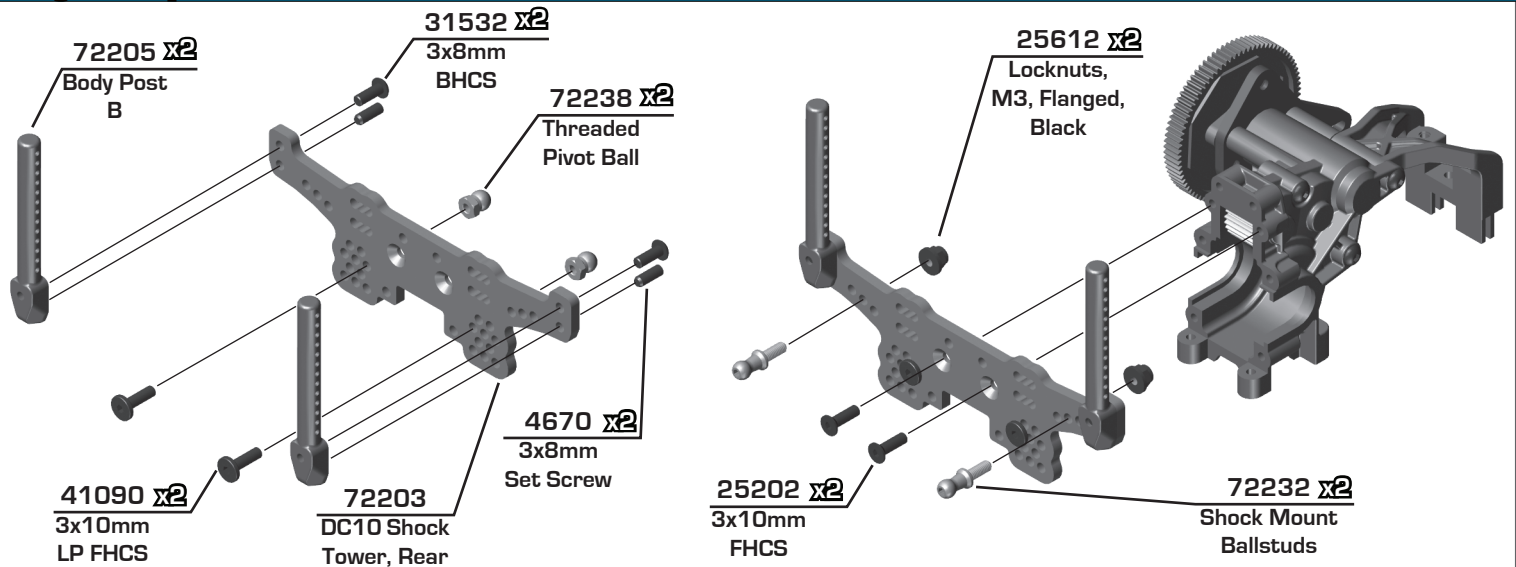

Bag 4 - Step 5

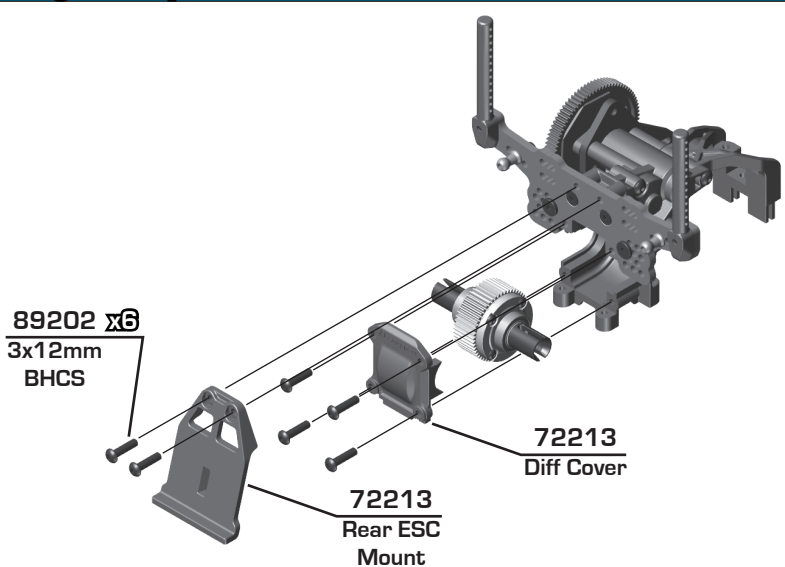

Bag 5 - Step 1

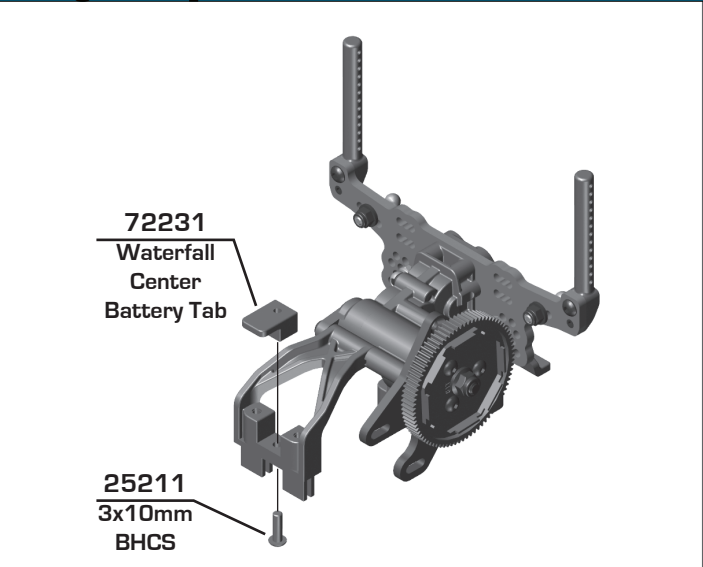

⚡ Bag 5 - Step 2

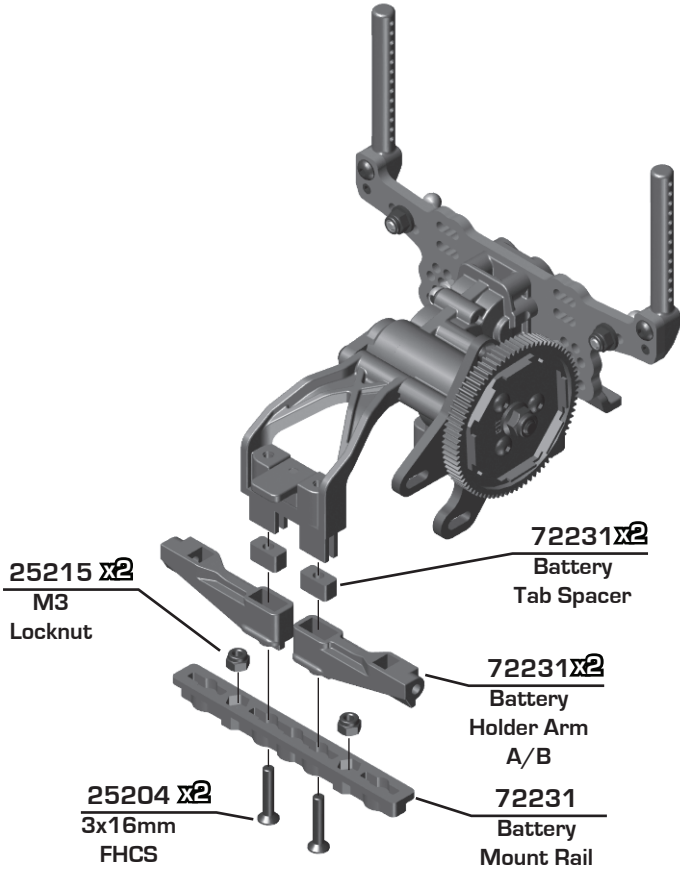

Note the battery holder arm positions when installing!

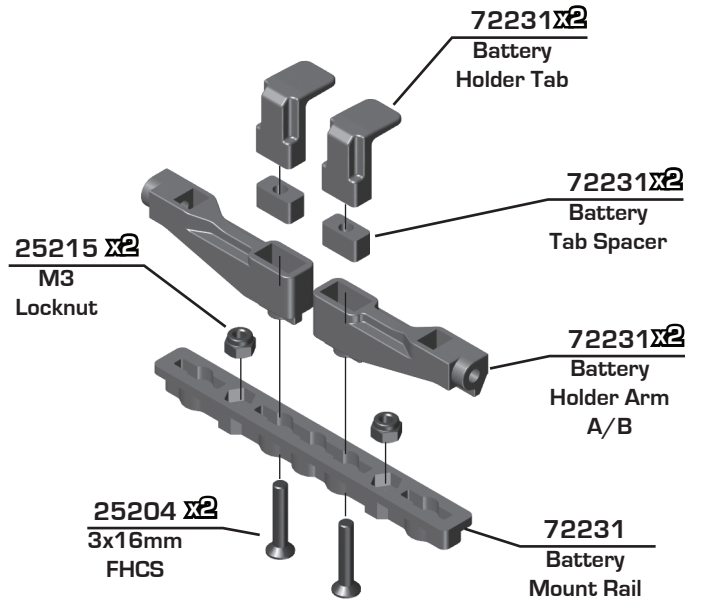

⚡ Bag 5 - Step 3

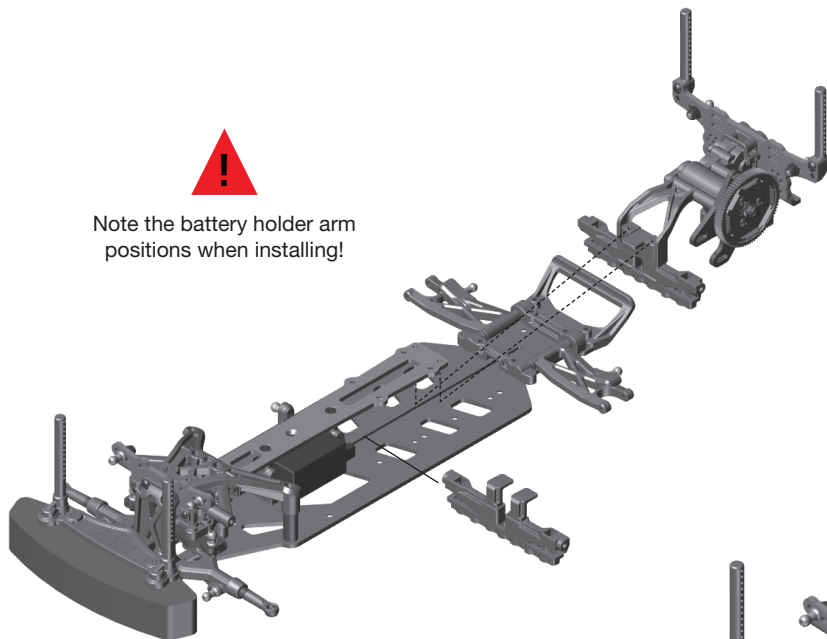

Note the battery holder arm positions when installing!

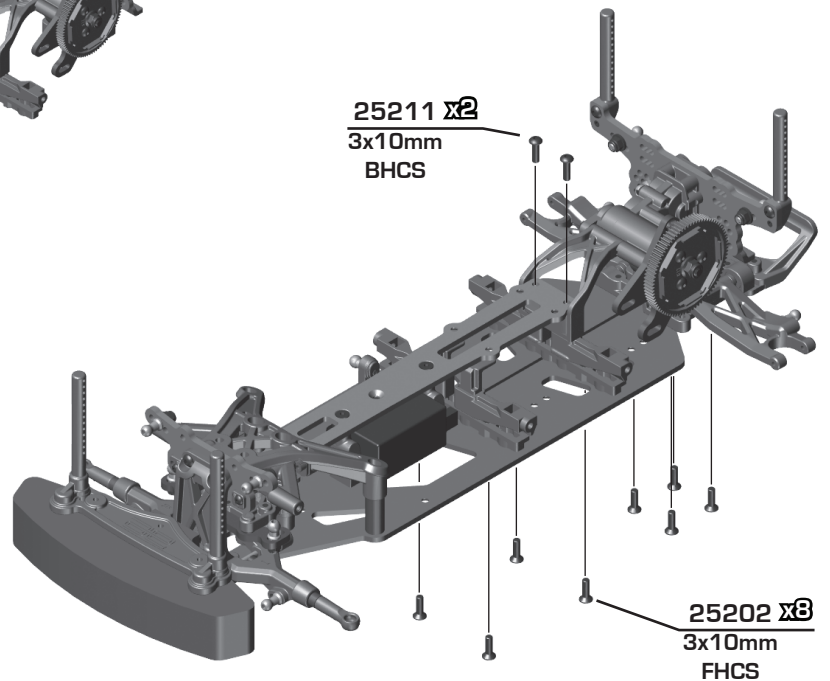

Bag 5 - Step 4

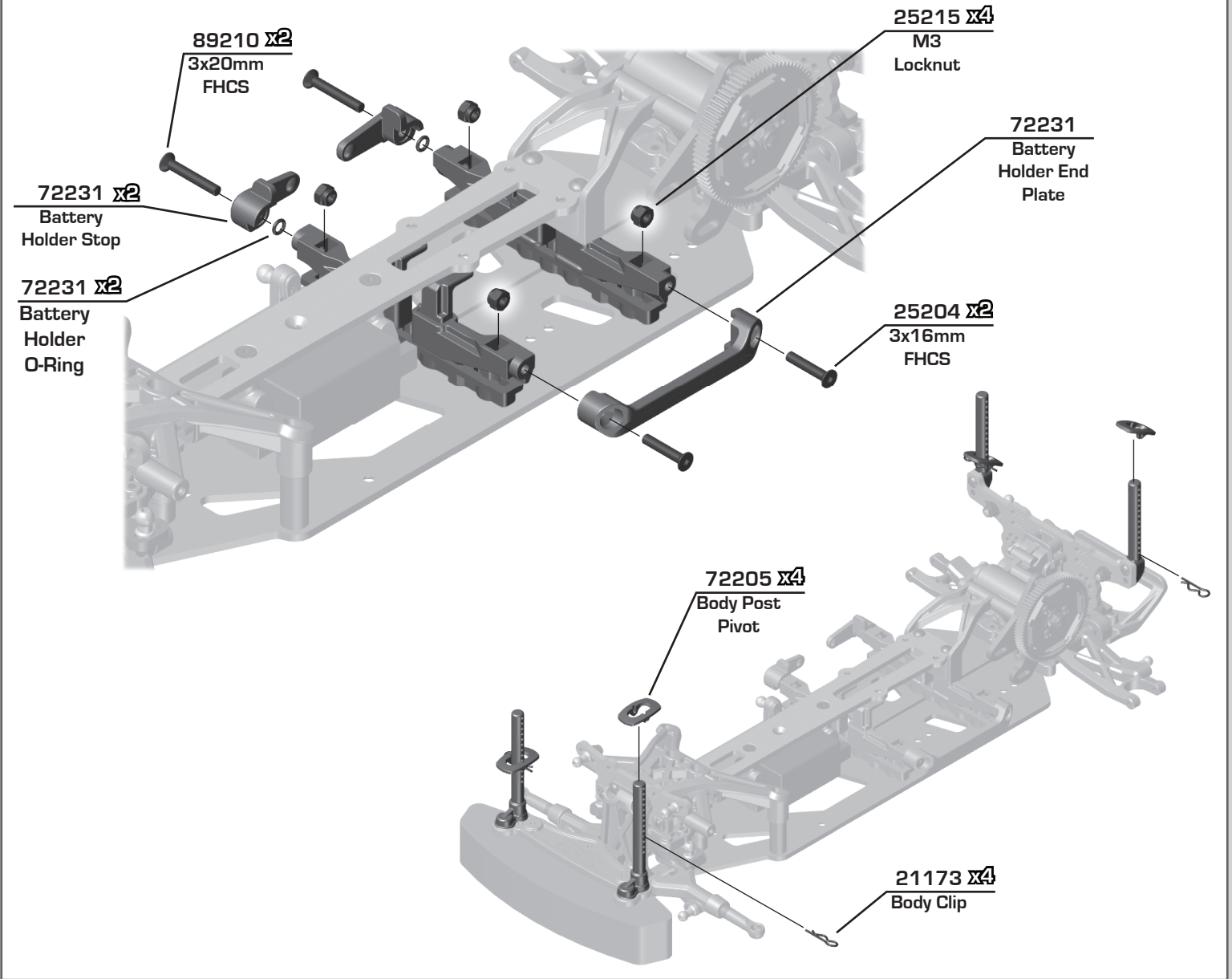

Bag 6 - Step 1

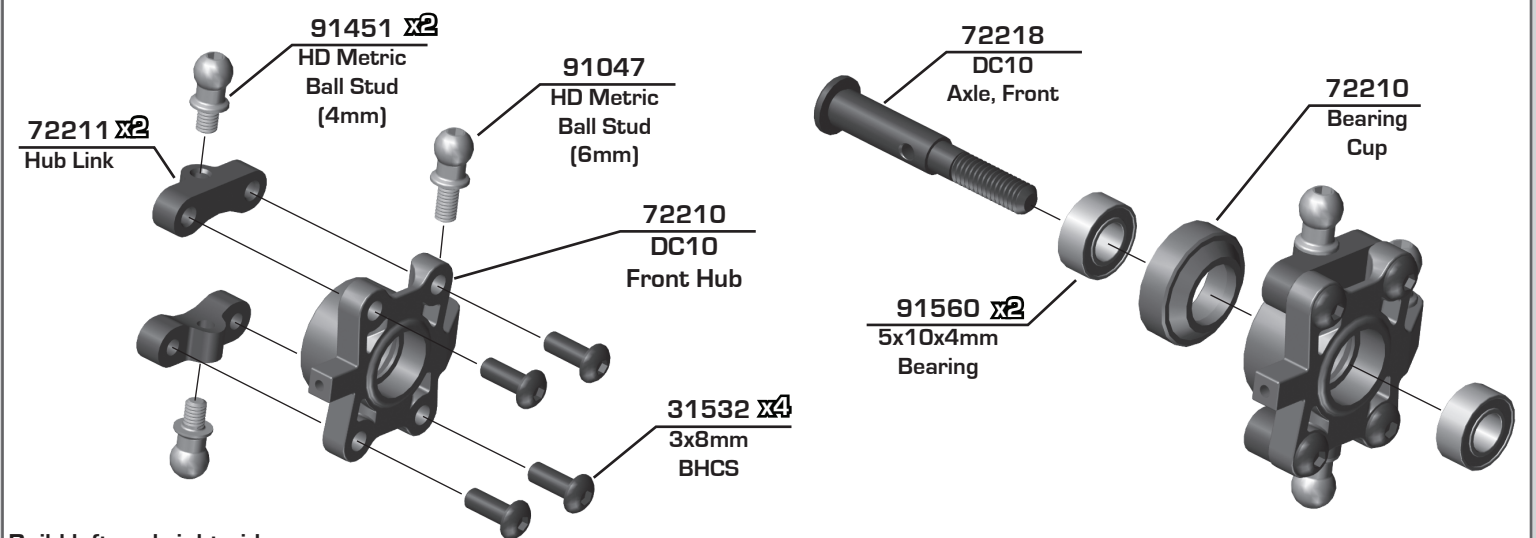

Build left and right sides

⚡ Bag 6 - Step 2

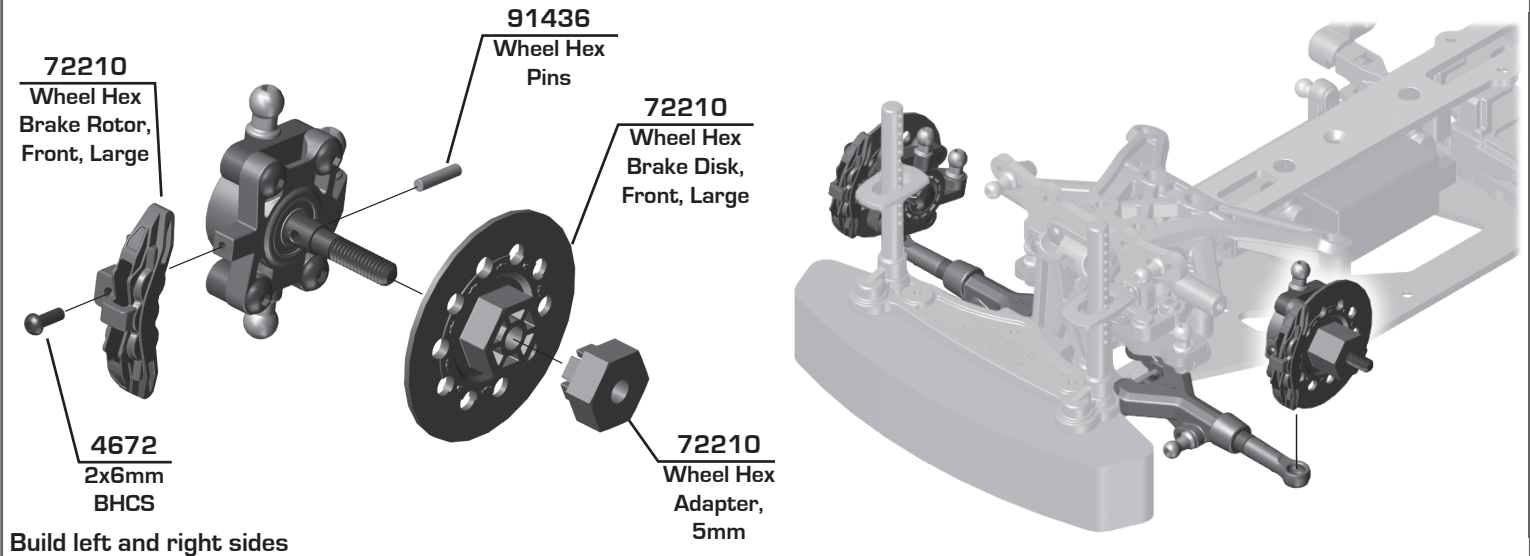

⚡ Bag 6 - Step 3

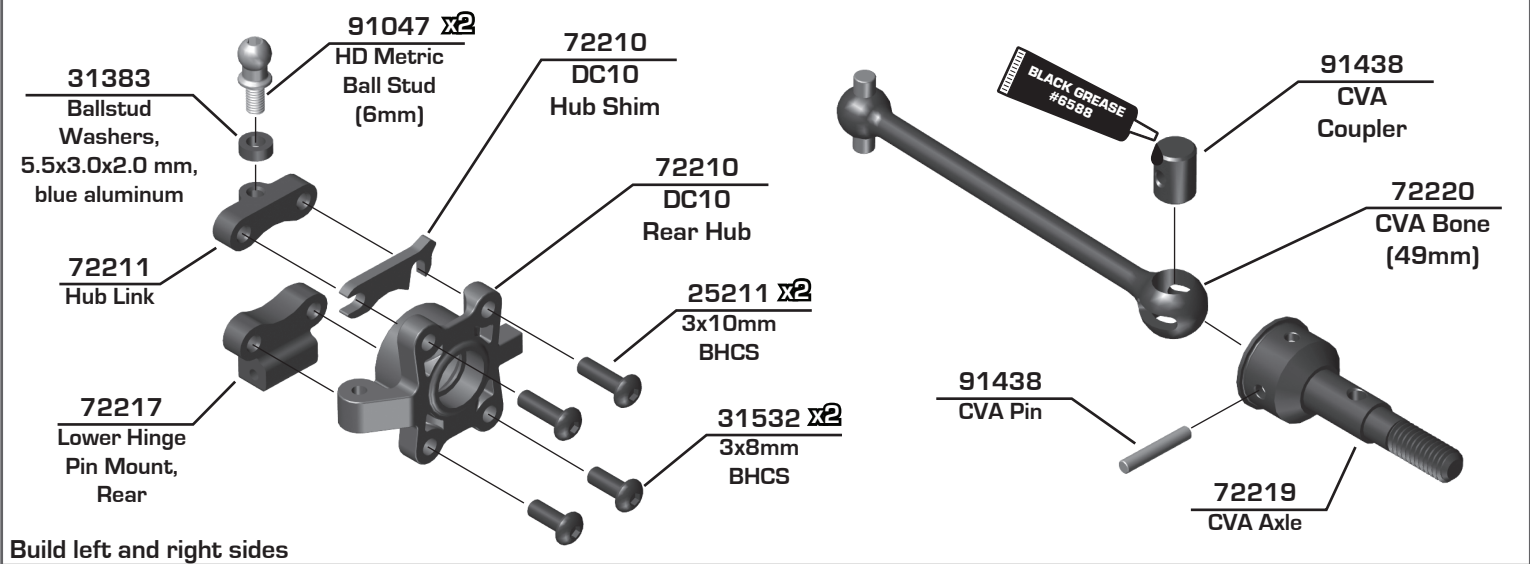

⚡ Bag 6 - Step 4

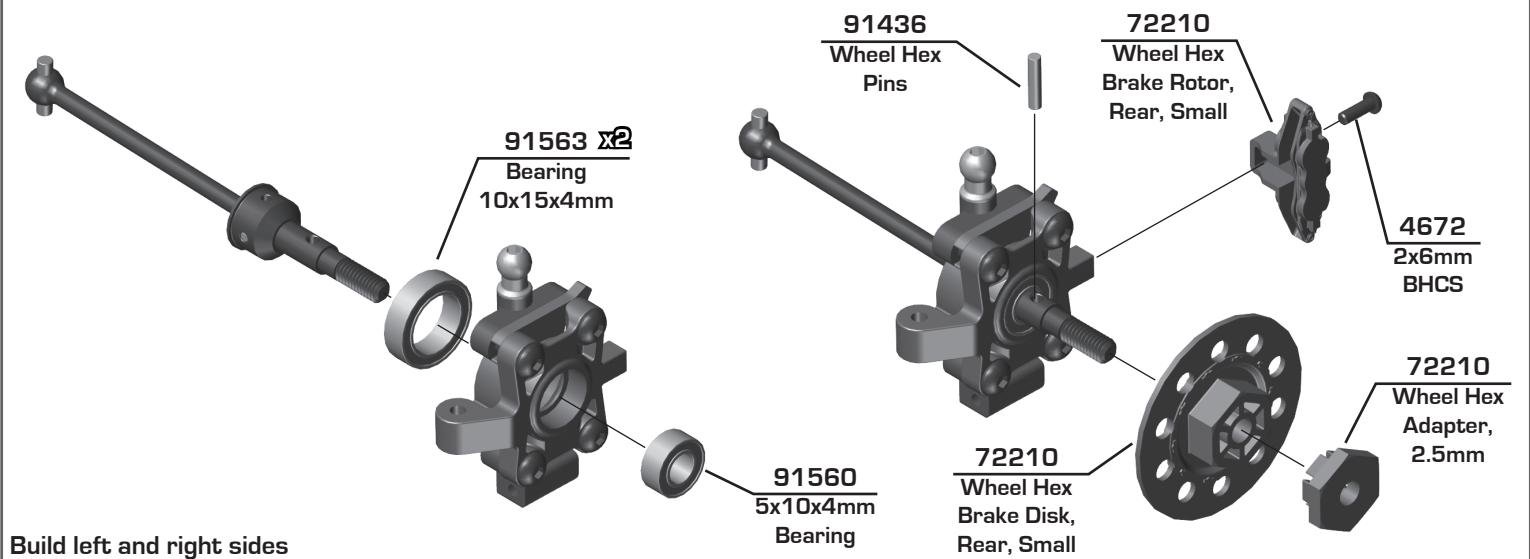

**:: Bag 6 - Step 5**

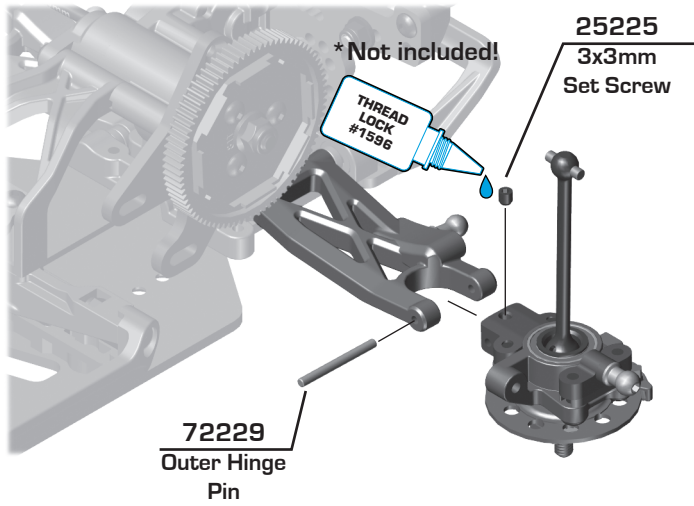

Build left and right sides



Rotate the rear hub and insert the CVA Bone into the Gear Diff Outdrive.

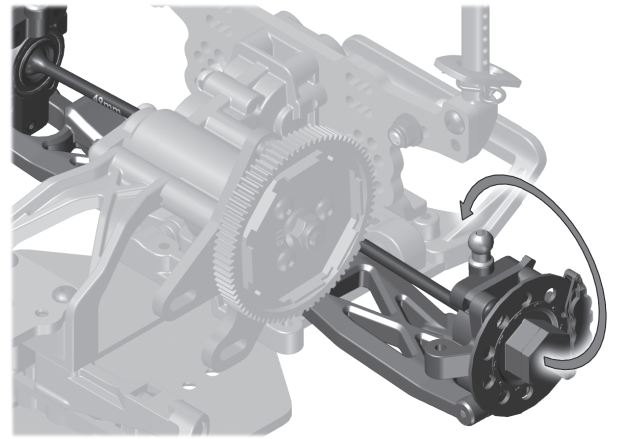

**:: Bag 7 - Step 1**

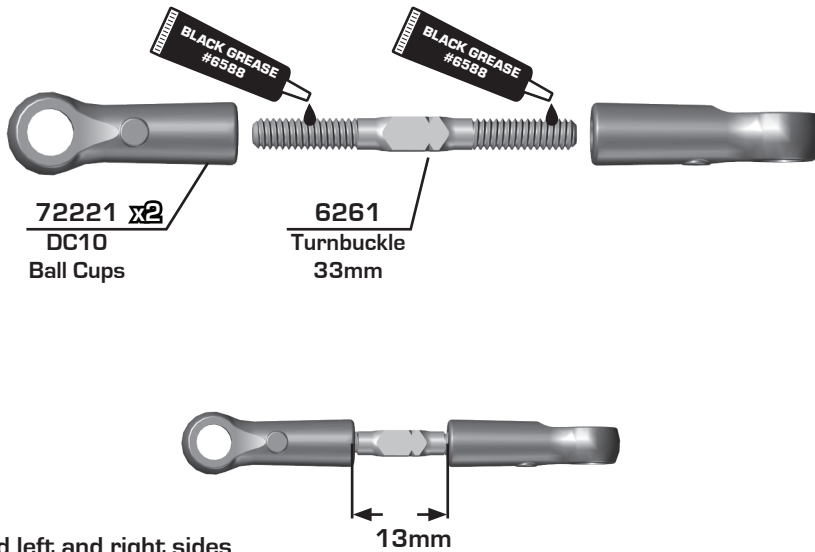

Build left and right sides

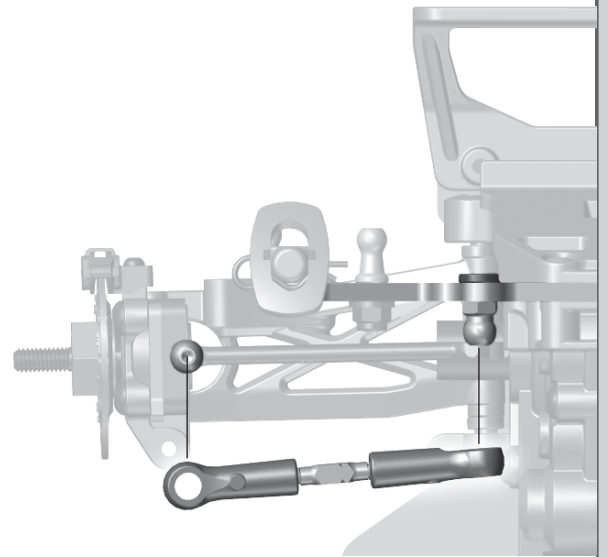

**:: Bag 7 - Step 2**

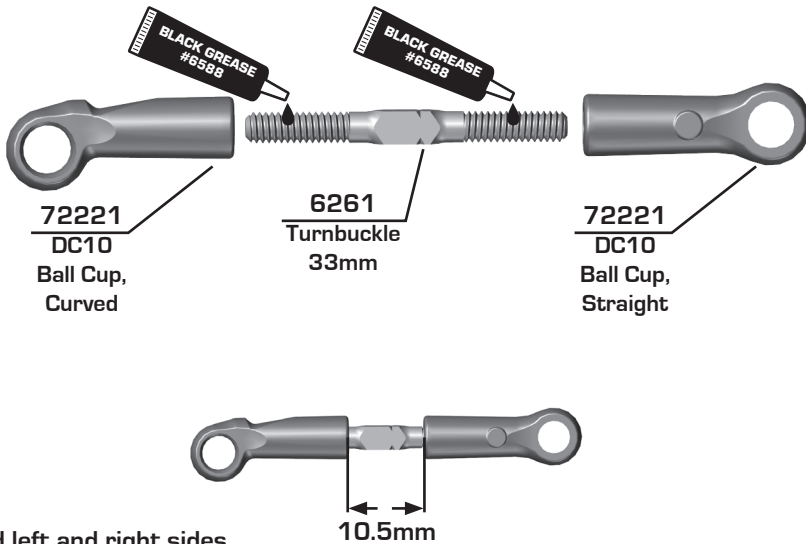

Build left and right sides

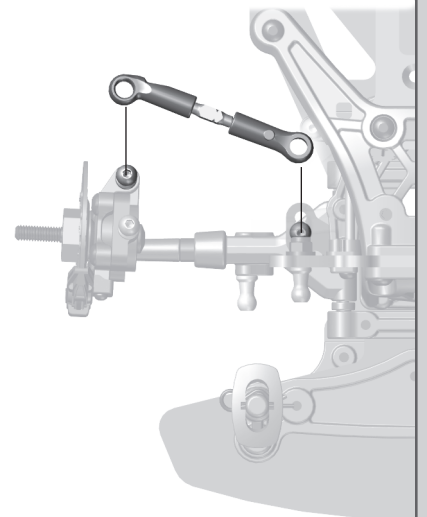



**:: Bag 7 - Step 3**

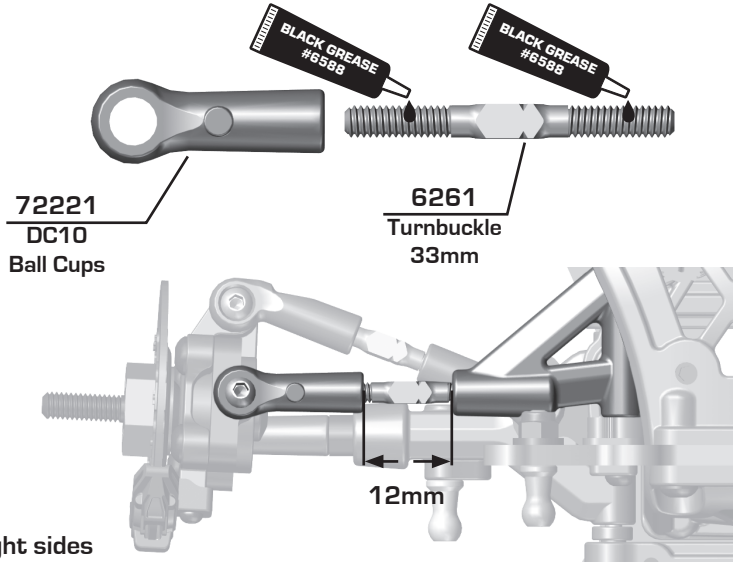

Build left and right sides

**:: Bag 7 - Step 4**

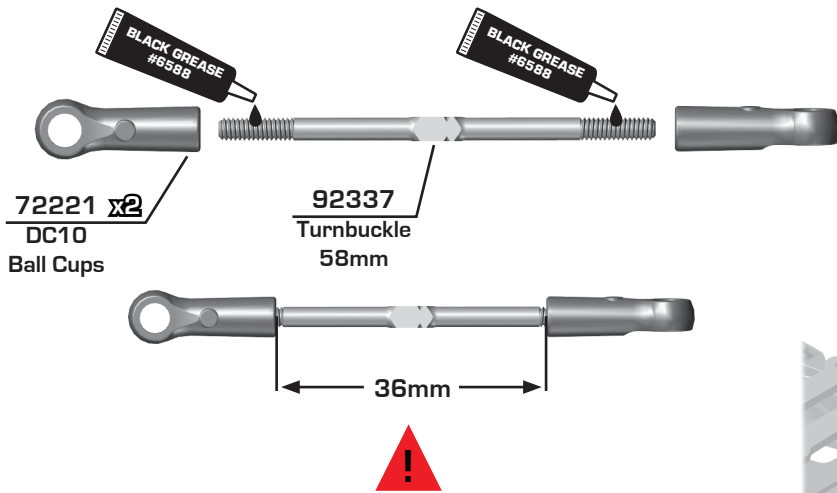

\*18mm if servo is flipped

Build left and right sides

**:: Bag 8 - Step 1**

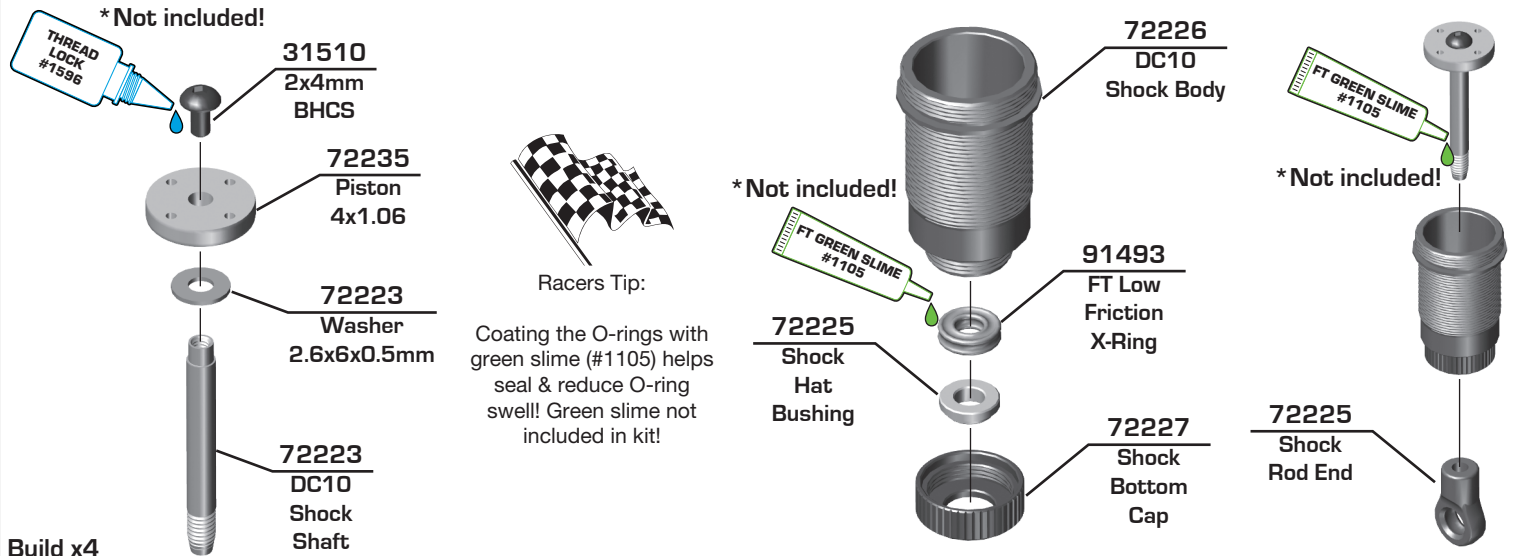

Build x4

**:: Bag 8 - Step 2**

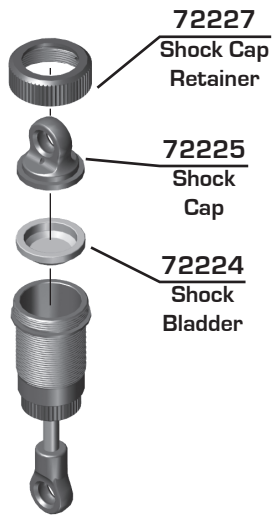

**!**  
Compress shock shaft fully. Let shock fluid bleed from cap, then tighten cap. For more rebound, do not compress shock shaft as far before tightening the shock cap.

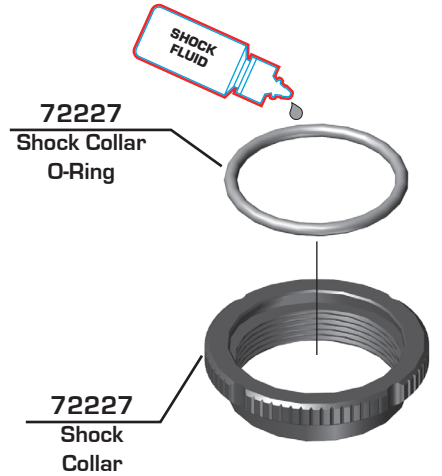

Build x4

**:: Bag 8 - Step 3**



Surface and Low or High Motor setup will determine what shock springs you should run.

Factory recommended springs for Low Motor setup:  
Front: Hard Yellow Spring  
Rear: Medium Soft Blue Spring

Factory recommended springs for High Motor setup:  
Front: Medium Green Spring  
Rear: Medium Soft Blue Spring



72222 Shock Spring Cup, Aluminum

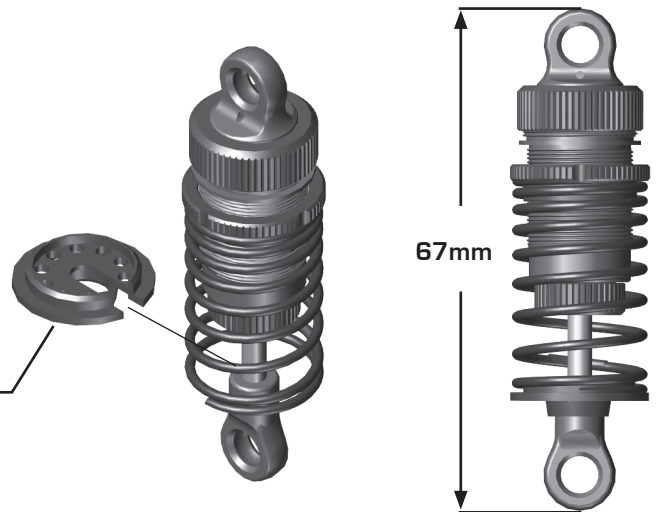

Build x4

**:: Bag 8 - Step 4**

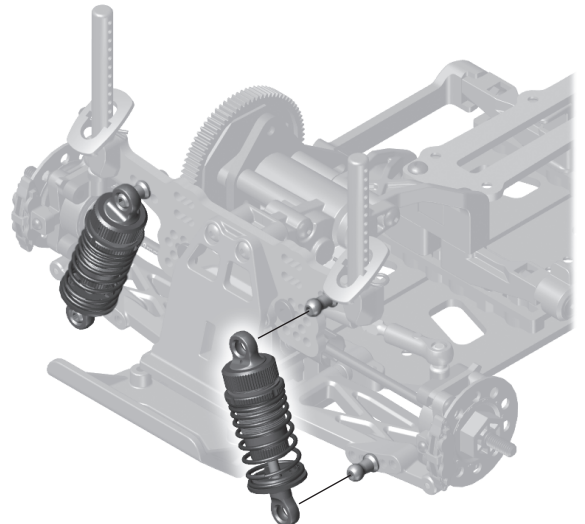
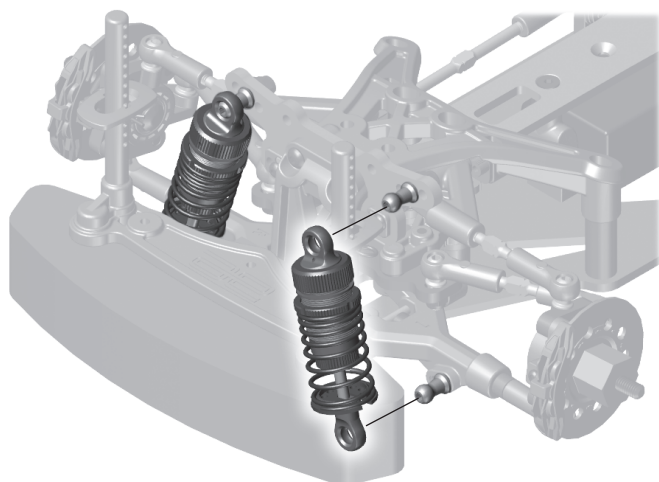

Build left and right sides

## Misc - Step 1

Motor not included!

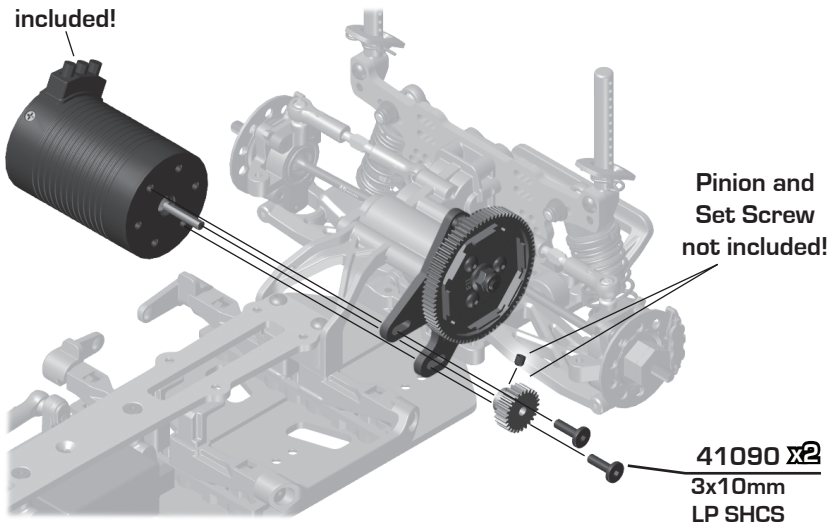

Pinion and Set Screw not included!

41090 x2  
3x10mm  
LP SHCS

### Set The Gear Mesh:

You should be able to rock the spur gear back and forth in the teeth of the pinion gear without making the pinion gear move. If the spur gear mesh is tight, then loosen the #41090 screws and move the motor away, then try again. A gear mesh that is too tight or too loose will reduce power and damage the gear teeth.

### Motor Gearing:

Gearing is dictated by the track surface, layout, motor wind and driver preference. Drifting leans heavily on the motors RPM to gain control.

Higher bite surfaces require a taller gearing for higher RPMs. (More wheel spin)

Recommended Motors for Drifting:

- 17.5: Starting Gearing: 72 spur x 26 pinion
- 17.5 Motors can be tuned to work well for drifting, however they generally have too much torque creating a digital feel at low speeds.
- 13.5: Starting gearing: 78 spur x 24 pinion
- Low torque, higher rpm 13.5 Motors are popular for drifting. This motor wind provides a controllable rpm range for most surfaces.
- 10.5: Starting gearing: 78 spur x 22 pinion
- High RPM 10.5 turn motors are another popular option for drifting. The higher rpms from a 10.5 give a wider tuning window. Usually larger spur gears are used with lower wind motors.

A taller gearing will provide a larger rpm window, warmer motor temps and shorter run times.

Gearing lower provides a smaller rpm window, cooler motor temps and longer run times.

## Misc - Step 2



Rotate the battery levers to install the battery. Rotate the levers back down to lock in the battery.

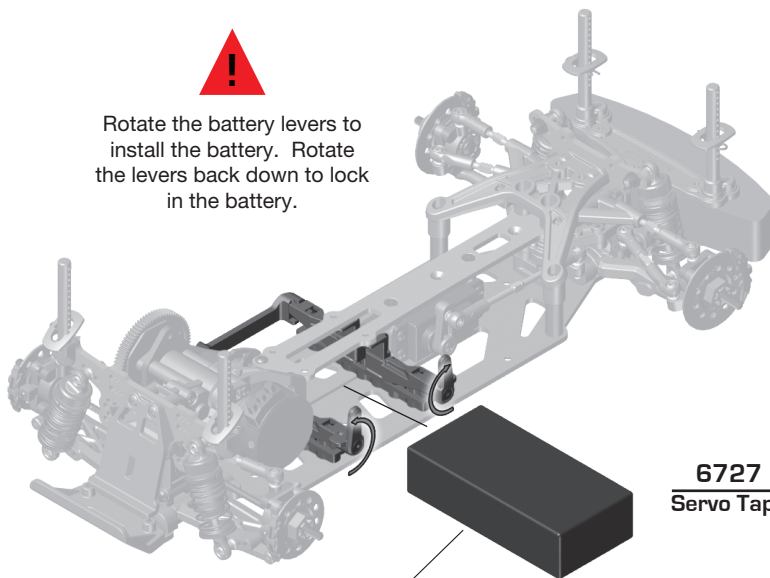

Battery not included!

6727 x3  
Servo Tape

Receiver not included!

Gyro not included!

ESC not included!

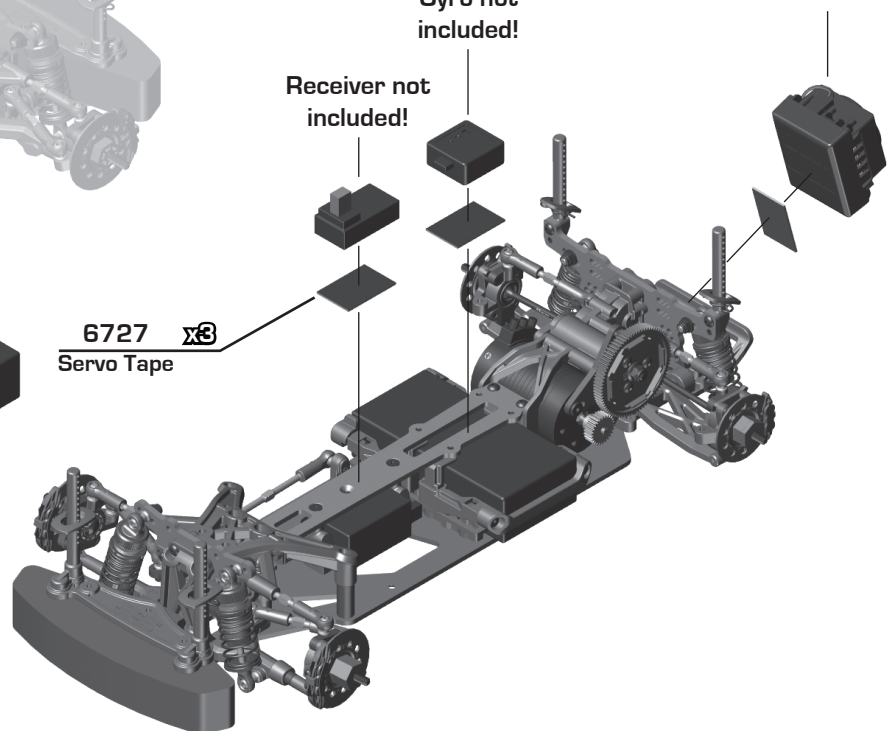

**:: Misc - Step 3**

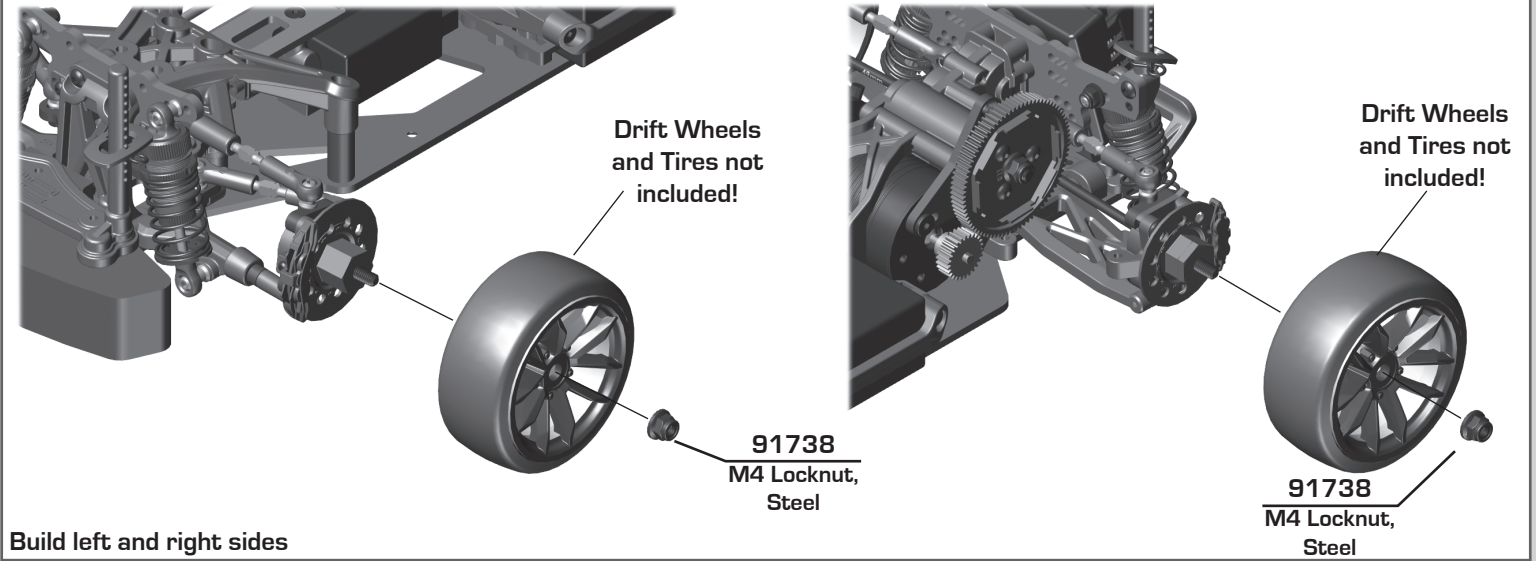

**:: Optional High Motor Mount - Step 1**

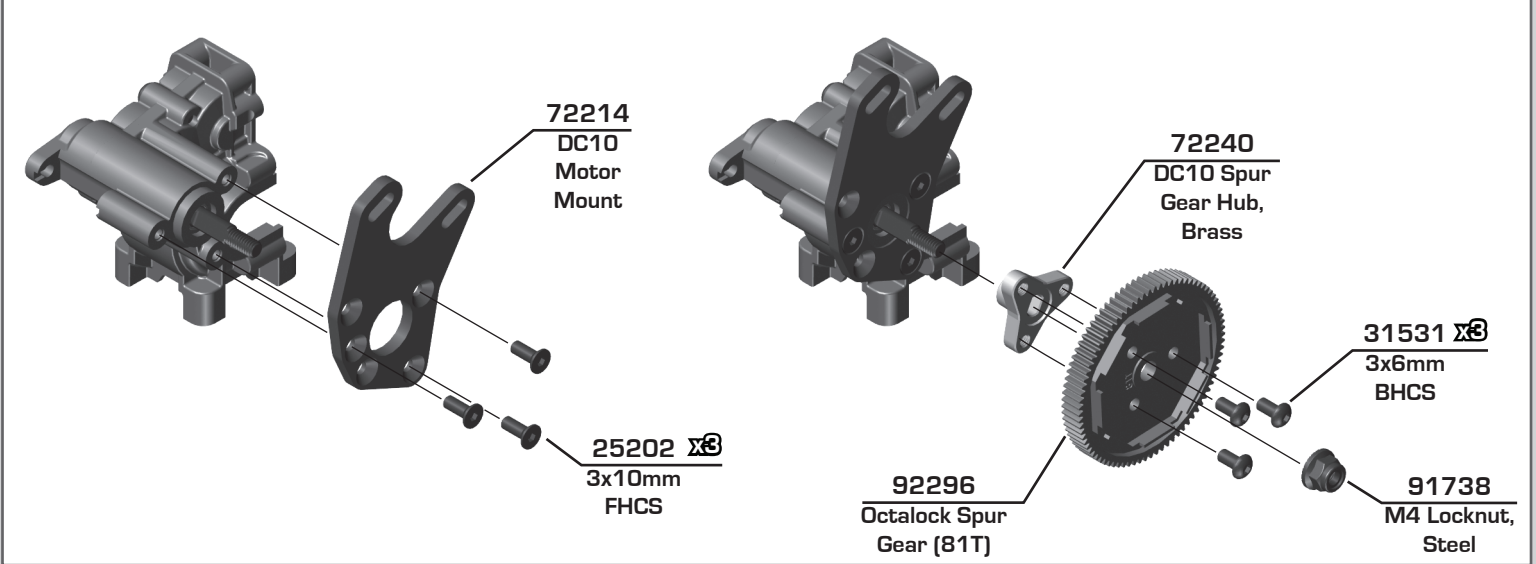

**:: Optional High Motor Mount - Step 2**

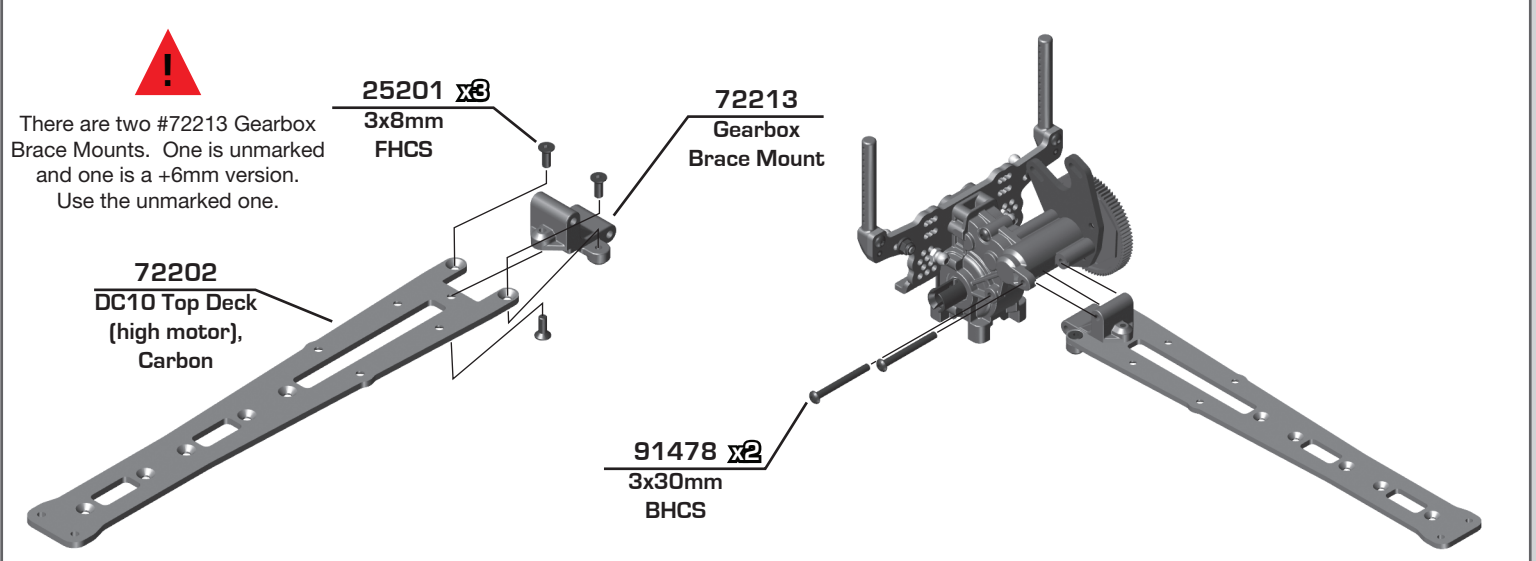

Optional High Motor Mount - Step 3



Note the battery holder arm positions when installing!

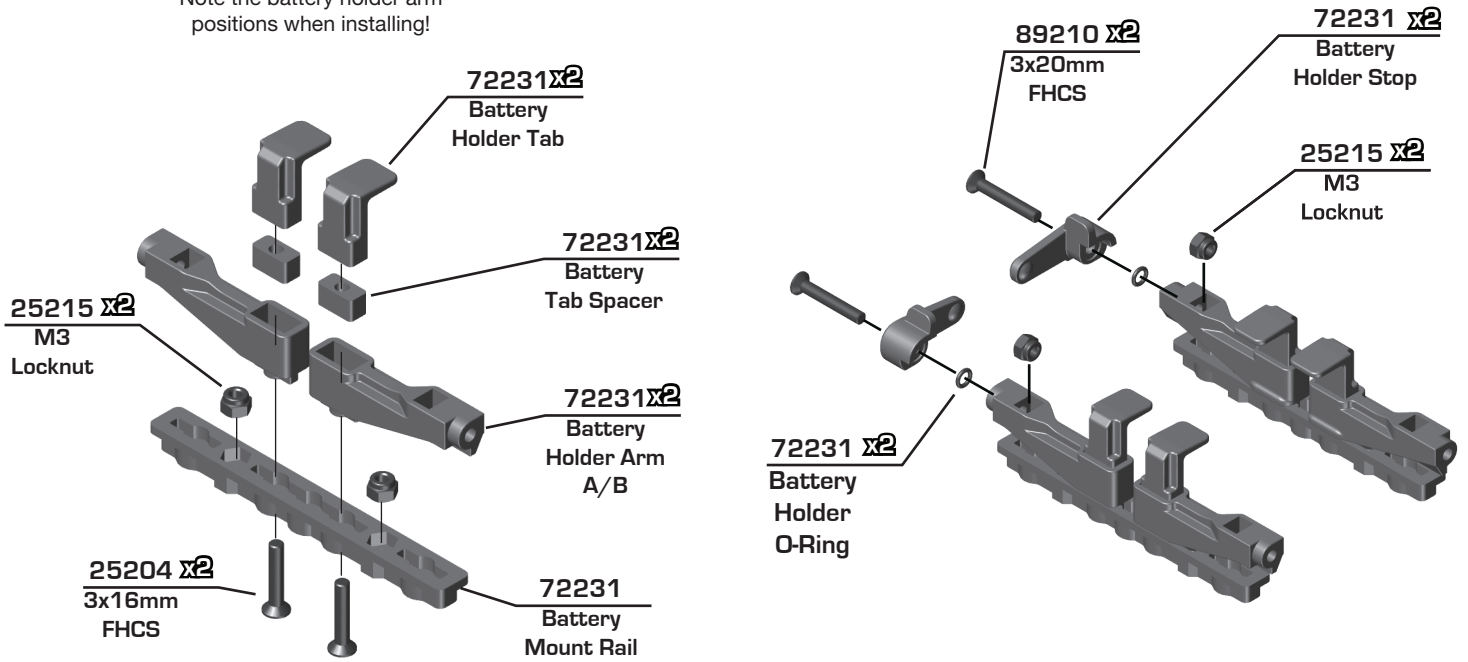

Build x2

Optional High Motor Mount - Step 4

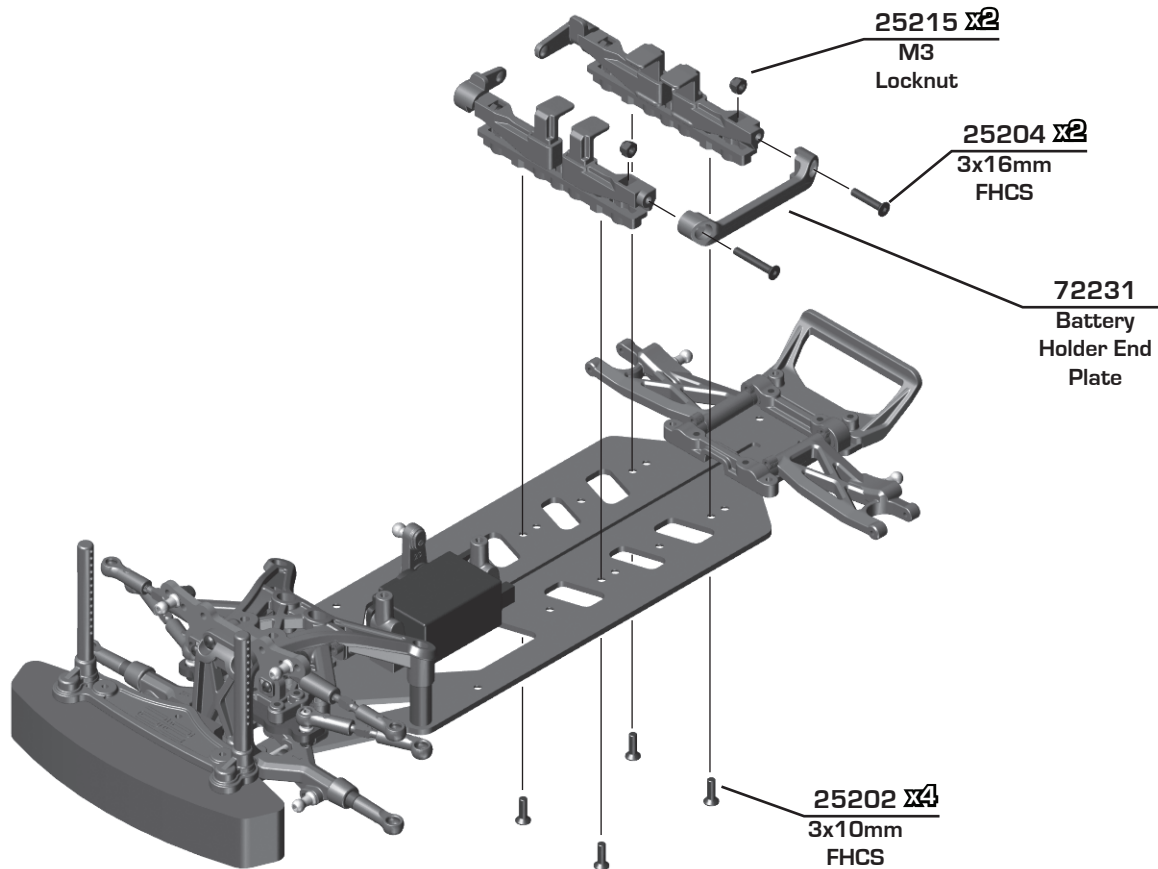

Optional High Motor Mount - Step 5

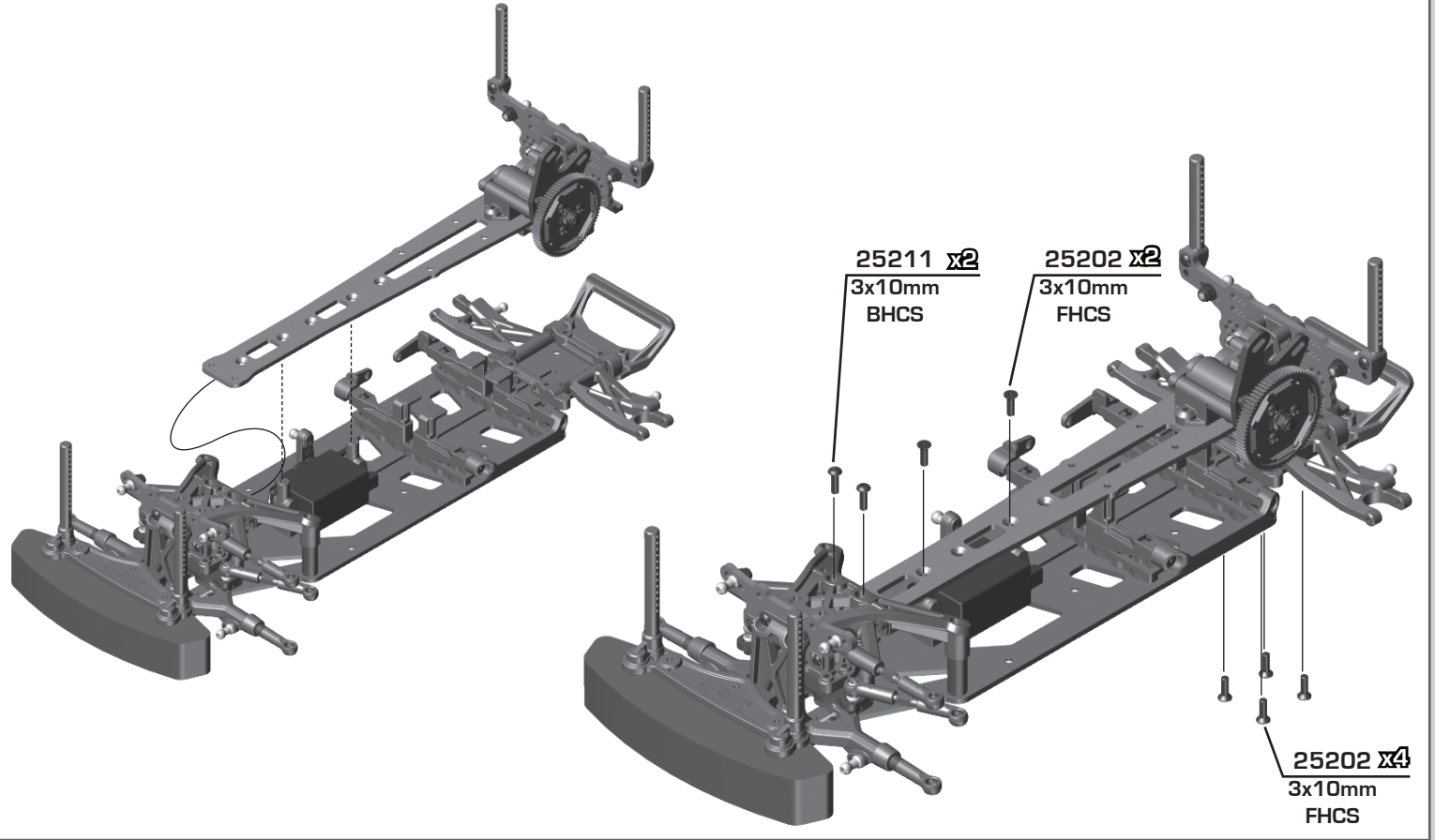

Optional High Motor Mount - Step 6

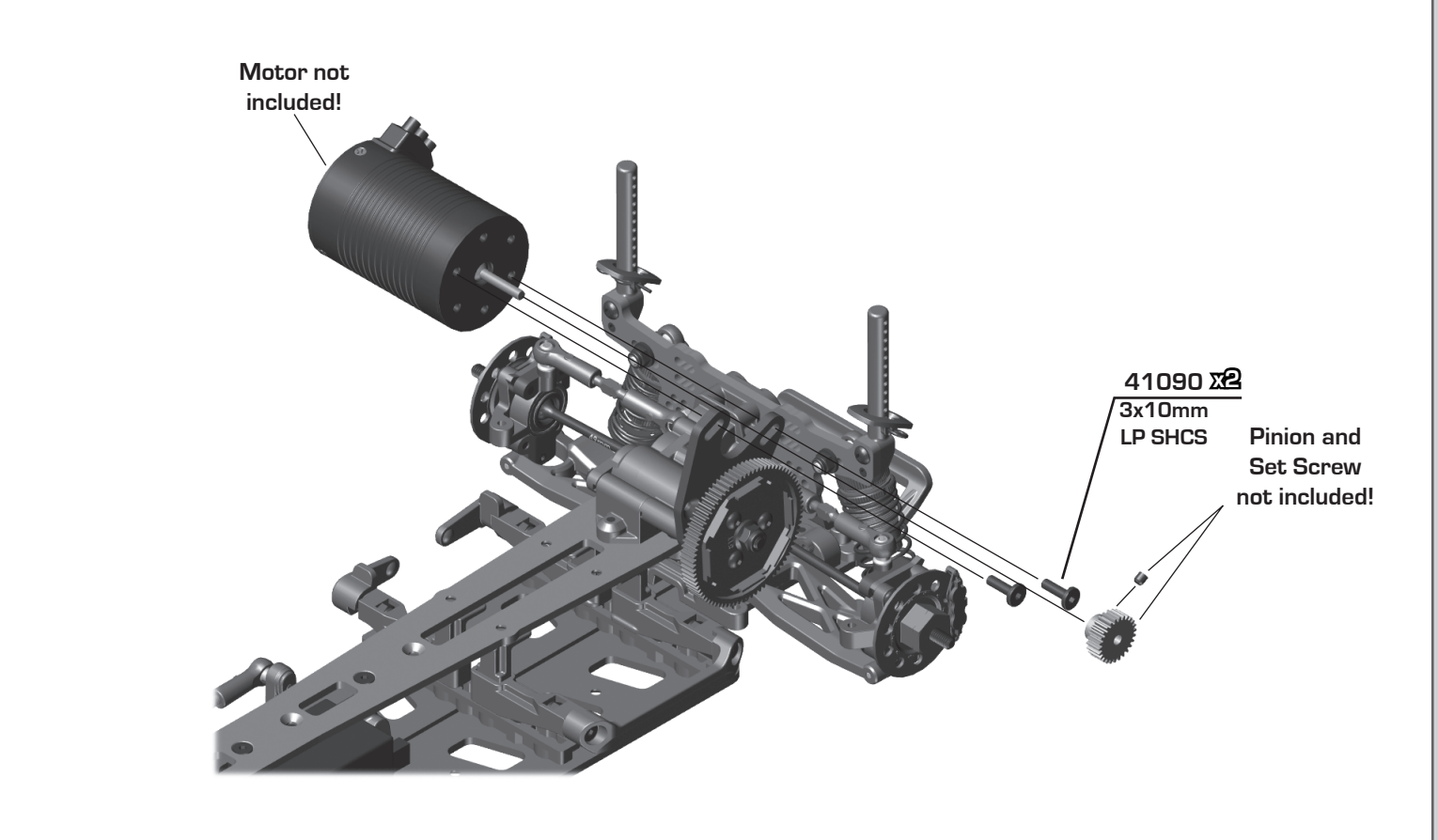

## Optional Spool Build - Step 1

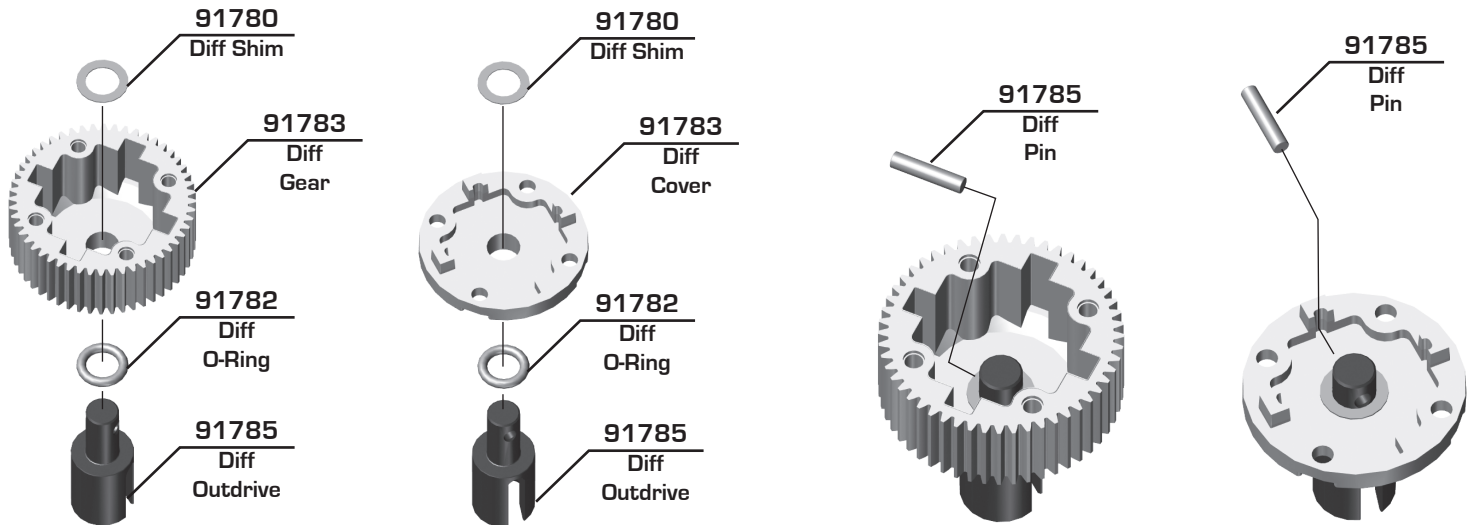

## Optional Spool Build - Step 2

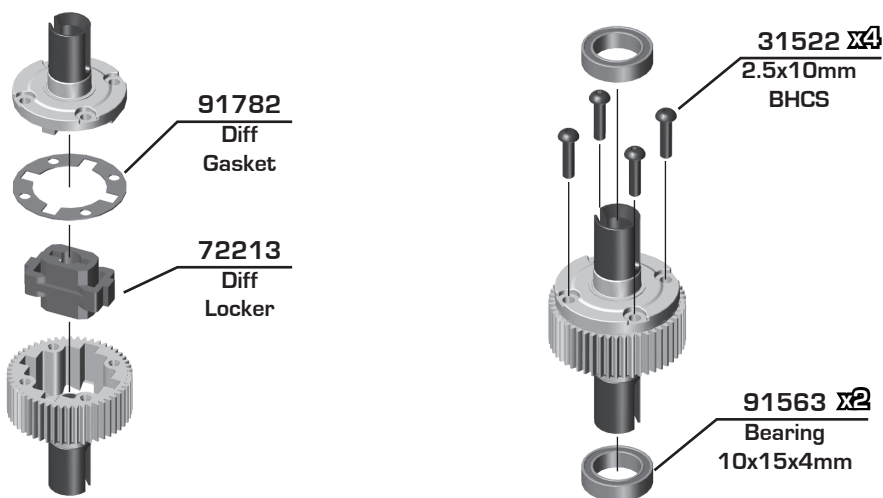

Racers Tip:

**Locked Diff:**  
Recommended for low grip surfaces and smoother driving style.

**Gear Diff:**  
Light grease for higher grip surfaces and 1000cst (80wt) for lower grip surfaces

## Tuning Tips - Painting, Beginners

### Painting:

Your Kit requires a clear polycarbonate body. You will need to prep the body before you can paint it. Wash the **INSIDE** thoroughly with warm water and liquid detergent (do not use any detergents with scents or added hand lotion ingredients!). Dry the body using a clean, soft, lint-free cloth. Use the supplied window masks to cover the windows from the **INSIDE** of the body (RC bodies get painted on the inside). Using high quality masking tape, apply tape to the inside of the body to create a design. Spray (use either rattle can or airbrush) the paint on the inside of the body (preferably dark colors first, lighter colors last). **NOTE: ONLY** use paint that is recommended for (polycarbonate) plastics. If you do not, you can destroy the body! After the paint has completely dried (usually after 24 hours), cut the body along the trim lines. Make sure to drill or use a body reamer to make the holes for the antenna if needed! Use hook and loop tape to secure the body to the side rails of the vehicle.

### Tips for Beginners:

Before making any changes to the standard setup, make sure you can get around the track without crashing. Changes to your vehicle will not be beneficial if you can't stay on the track. Your goal is consistent laps. Once you can get around the track consistently, start tuning your vehicle. Make only **ONE** adjustment at a time, testing it before making another change. If the result of your adjustment is a faster lap, mark the change on the included setup sheet (make additional copies of the sheet before writing on it). If your adjustment results in a slower lap, revert back to the previous setup and try another change. When you are satisfied with your vehicle, fill in the setup sheet thoroughly and file it away. Use this as a guide for future track days or conditions. Periodically check all moving suspension parts. Suspension components must be kept clean and move freely without binding to prevent poor and/or inconsistent handling.

⌘ Notes

Blank area for notes.



Notes

Blank area for notes.

# FIND IT ON ASSOCIATEDELECTRICS.COM

## CARS & TRUCKS

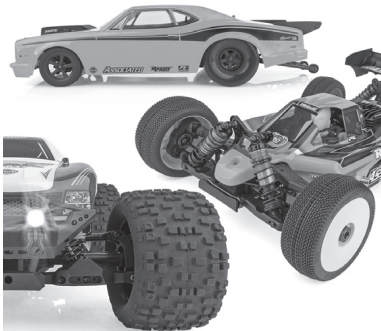

### Vehicle Spare Parts

GO TO:

- AssociatedElectrics.com →
- Team Associated tab →
- Cars & Trucks →
- Scroll to your vehicle →
- Parts & Accessories link

## SETUP SHEETS & MANUALS



### Setups and Manuals

GO TO:

- AssociatedElectrics.com →
- Team Associated tab →
- Manuals & Setups →
- Scroll to your vehicle

## A-TEAM APPS



### Tuning Guides & Tips

GO TO:

- AssociatedElectrics.com →
- Support →
- A-Team Apps



**Associated Electrics, Inc.**

**21062 Bake Parkway Lake Forest, CA 92630 USA**

**call: (949) 544-7500 - fax: (949) 544-7501**

**Check out the following web sites for all of our kits, current products,  
new releases, setup help, tips, and racing info!**

**[www.AssociatedElectrics.com](http://www.AssociatedElectrics.com)**

**FOLLOW US ON SOCIAL MEDIA**

