

Front Suspension

Anti Roll Bar:

- 0.047" Black
 0.055" Silver
 None

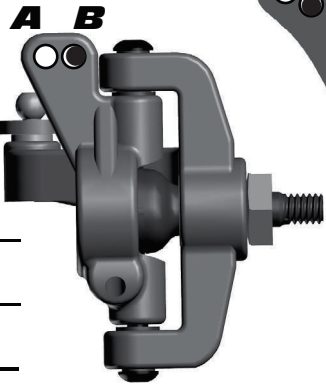

Bumpsteer

Washer: 1 mm In / 1 mm Out

Camber: -1

Toe: 0

Ride Height: 21 mm

Washers: 1 mm

Steering Rack:

Front:
Back:

1 0

Notes:

Rear Suspension

Reset Forms

Anti Roll Bar:

- 0.047" Black
 0.055" Silver
 None

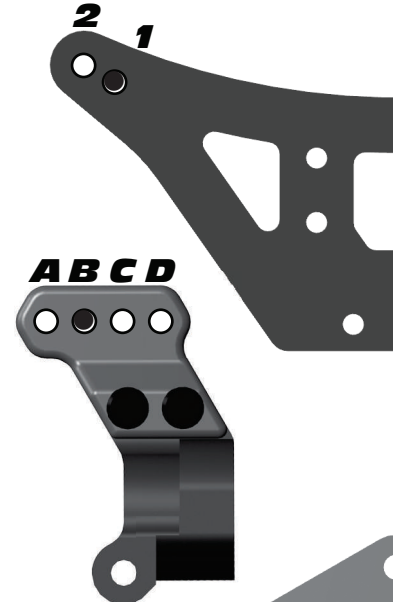

Camber: -1

Toe: 3

Anti-Squat: 0.030

Ride Height: 20 mm

Aluminum Hub Tower:

- A
 B
 C

Wheelbase:

- Long
 Medium
 Short

Ballstud Washers: 1 mm

1 0

Notes:

Front Shocks

Spring: Kyo Orange **Piston:** #55 x 4
Shock Oil: 35 wt **Limiter:** 1

Rear Shocks

Spring: Kyo Gold **Piston:** #54 x 4
Shock Oil: 30 wt **Limiter:** 1

Electronics

Motor & Wind: Reedy Sonic 6.5
Pinion: 18
Spur Gear: 81
Batteries: Reedy 5200 mAh 65C #627
Battery Placement: Stock
Ballast Weight: 50g

Radio: Futaba 4pks
Throttle / Brake e.p.a.: 100% / 80%
Throttle / Brake expo: -10% / 0%
ESC: LRP SXX TC V2 **ESC Software:** 3.0
ESC Profile: 1 --- 0 --- 2 --- 5
Servo: Futaba 9353 **Steering Expo:** 0%

Differentials

Front Diff Setting: Standard
Rear Diff Setting: Tight

Other

Body Type: JConcepts Finisher
Wing Type: JConcepts High Flow **Wing Angle:** 6 Deg

Front Tires

Tire: JConcepts Barcode
Compound: Orange
Insert: Closed Cell
Wheel: JConcepts Mono

Rear Tires

Tire: JConcepts Barcode V2
Compound: Orange
Insert: Closed Cell
Wheel: JConcepts Mono

Race and Vehicle Comments

Qualify: 2 **Main:** A **Finish:** 1 **TQ:** _____
Comments: Prototype Associated 12mm shocks

Track Info

Traction: High: Medium: Low:
Smooth: **Bumpy:** **Blue Groove:**
Soft Dirt: **Grass:** **Clay:** **Wet:**
Dusty: **Other:** _____