

### Front Suspension

**Anti Roll Bar:**

- 0.047" Black   
 0.055" Silver   
 None

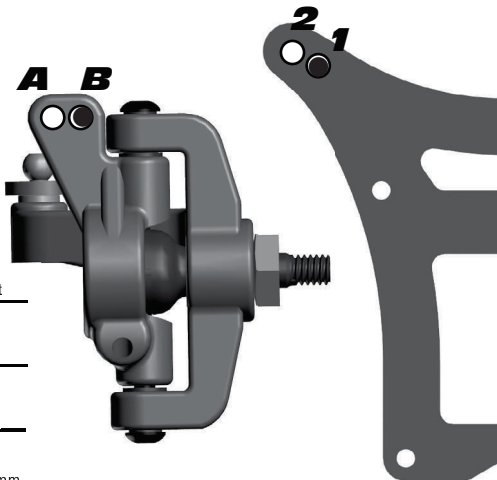

**Bumpsteer**

**Washer:** 1mm In / 1mm Out

**Camber:** -1

**Toe:** 0

**Ride Height:** 21 mm

**Washers:** 0.030

**Steering Rack:**

**Front:**  
**Back:**



**Notes:**  
 \_\_\_\_\_  
 \_\_\_\_\_  
 \_\_\_\_\_

### Rear Suspension

Reset Forms

**Anti Roll Bar:**

- 0.047" Black   
 0.055" Silver   
 None



**Camber:** -1

**Toe:** 3\*

**Anti-Squat:** 3\*

**Ride Height:** 20 mm

**Aluminum Hub Tower:**

- A   
 B   
 C

**Wheelbase:**  
 Long   
 Medium   
 Short

**Ballstud Washers:** 0.030



**Notes:**  
 \_\_\_\_\_  
 \_\_\_\_\_  
 \_\_\_\_\_

### Front Shocks

**Spring:** Kyo 12mm Yellow **Piston:** #2  
**Shock Oil:** 35 wt Associated **Limiter:** 1

### Rear Shocks

**Spring:** Kyo 12mm White **Piston:** #1  
**Shock Oil:** 30 wt Associated **Limiter:** 0

### Electronics

**Motor & Wind:** Reedy Sonic 6.5 / Orion Vortex 6.5  
**Pinion:** 19 / 18  
**Spur Gear:** 81  
**Batteries:** Reedy 60C SP 5200 mAh / Orion  
**Battery Placement:** Standard  
**Ballast Weight:** 50g / 90g

**Radio:** Airtronics M11x  
**Throttle / Brake e.p.a.:** 100% / 90%  
**Throttle / Brake expo:** 0% / 0%  
**ESC:** LRP SXX TC V2 **ESC Software:** 3.0  
**ESC Profile:** 1 --- 0 / 5 --- 0 / 2 --- 2  
**Servo:** Airtronics **Steering Expo:** 0%

### Differentials

**Front Diff Setting:** Tight  
**Rear Diff Setting:** Tighter

### Other

**Body Type:** JConcepts Finisher / Pro-Line Bull Dog  
**Wing Type:** JC High Clearance / PL 5.5" **Wing Angle:** 3" / 9"

### Front Tires

**Tire:** JConcepts Barcode  
**Compound:** Gold  
**Insert:** Proline Closed Cell  
**Wheel:** Associated

### Rear Tires

**Tire:** Proline Suburb  
**Compound:** MC  
**Insert:** Proline Closed Cell  
**Wheel:** JConcepts Hex / Proline Hex

### Race and Vehicle Comments

**Qualify:** \_\_\_\_\_ **Main:** \_\_\_\_\_ **Finish:** \_\_\_\_\_ **TQ:** \_\_\_\_\_  
**Comments:**  
 \_\_\_\_\_  
 \_\_\_\_\_  
 \_\_\_\_\_

### Track Info

**Traction:** High:  Medium:  Low:   
**Smooth:**  Bumpy:  Blue Groove:   
**Soft Dirt:**  Grass:  Clay:  Wet:   
**Dusty:**  Other: \_\_\_\_\_