

For Immediate Release: December 2024

#7066 Team Associated RC10GT Classic

**NITRO ■ OFF ROAD ■ 1:10 SCALE ■ 2 WHEEL DRIVE ■ KIT**

Originally released in 1993 the RC10GT changed the world of RC Racing by introducing nitro engines into the competitive world of RC Racing. With more wins than we can count, the RC10GT has forged itself as the most iconic gas truck ever created. We are excited to announce the RC10GT lives on with this exclusive Gold Edition RC10GT.

ENGINEERED FROM OVER 20 YEARS OF GAS RACING EXPERIENCE.

Don't confuse Team Associated's RC10GT with aftermarket conversions or other gas-powered trucks. Our RC10GT is the real thing, designed and engineered by the same racers that brought you the first RC10, and has been winning RC gas championships for over 5 decades. Created to take full advantage of gas power, the RC10GT is the most advanced, high-performance vehicle of its kind. Like its electric cousin, the RC10T, the RC10GT features competition proven, four-wheel suspension with precision, gold anodized coil-over shock dampening.

Our world-famous Team Associated Stealth ATC gearbox is also adapted to the RC10GT, to get all that nitro power to the ground, and our race-ready disc brake gets it all slowed down in a hurry. And like all our kits, hardware and materials are nothing but the best.

Enjoy the sound and power that makes gas RC racing come alive. The RC10GT is the ONLY RC gas truck with Team Associated's total performance and reliability.

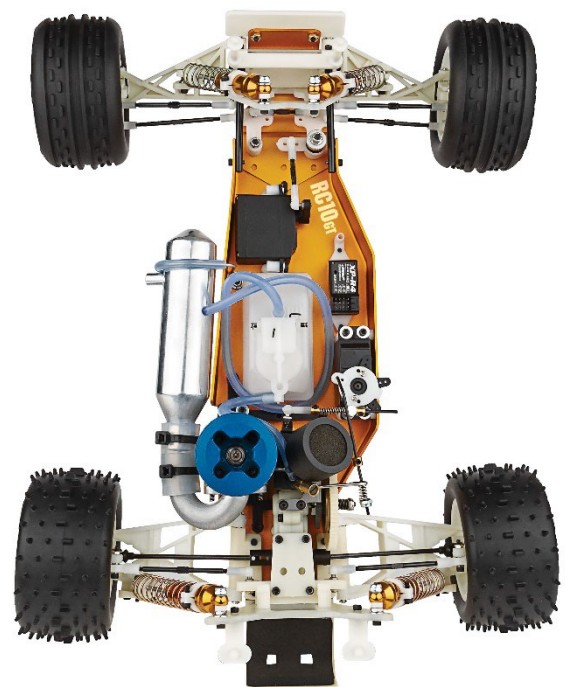

IFMAR World Champion factory drivers Brian Kinwald and Cliff Lett teamed with **Curtis Husting** in designing, track testing and racing Team Associated's **RC10GT** prototypes.

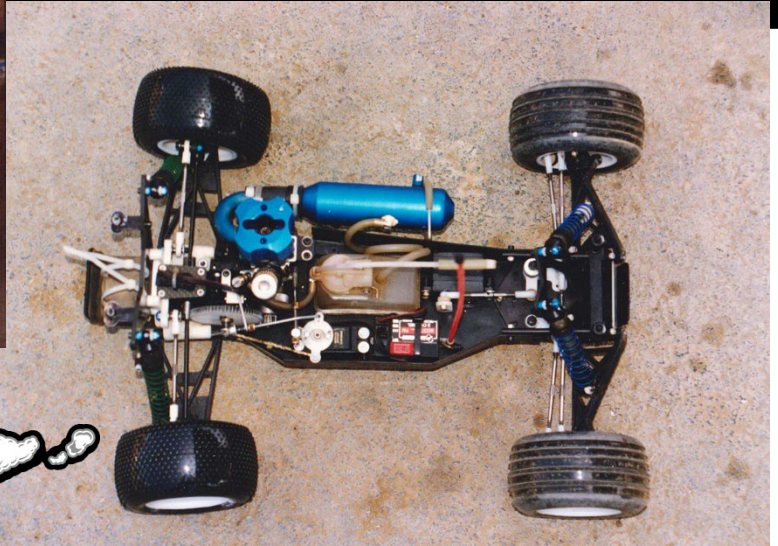

RC10GT

1:10 SCALE COMPETITION GAS TRUCK
GOLD EDITION

Designed to fit all popular .12 - .15 displacement 2-stroke model engines. We highly recommend using the more popular .12 size.

Stagger block front and pin spike rear tires developed by Team Associated specifically for the RC10GT.

Quick-fill 75cc fuel tank lets you race as long as you want with simple 2-second pit stops.

Latest generation, Team Associated precision-machined, gold anodized alloy racing shocks absorbers.

Wide track, long throw suspension, molded from rugged, lightweight and dyeable resilient virgin nylon.

Associated's legendary deep-drawn aircraft alloy monocoque tub chassis has been carefully adapted to gas power and features a laser etched RC10GT logo.





TEAM ASSOCIATED

Undefeated ROAR National Champion

The Team Associated RC10GT was a revolutionary vehicle in the world of RC racing. Released in 1993, the RC10GT was designed as a nitro-powered stadium truck, building upon the legacy of Team Associated's earlier successes with electric models like the RC10 buggy. With a focus on durability, performance, and user-friendliness, the RC10GT quickly became a dominant force in the growing segment of nitro RC racing. Its robust chassis, advanced suspension system, and excellent power-to-weight ratio made it a favorite among enthusiasts and racers alike.

When the RC10GT hit the market, it was a significant release for the RC community because it merged the excitement of nitro power with the precision and handling of competitive racing vehicles. Early RTR models featured a 0.12 cubic inch engine and came pre-assembled or as kits without an engine, allowing users to either customize their build or get straight into the action. The vehicle's adaptability and consistent performance earned it widespread acclaim.



Throughout its production run, the RC10GT went undefeated with numerous ROAR Gas Truck National Championship titles. Its innovative design, including adjustable suspension, precision steering, and rugged construction, made it a popular choice for professional racers. The RC10GT was often the vehicle of choice in competitions, earning championships at major RC racing events. Drivers like Brian Kinwald, Cliff Lett, Richard Saxton, Billy Easton, Mark Pavidis, and Jared Tebo, who were instrumental in Team Associated's racing success, helped cement the RC10GT's reputation as a top-tier racing truck.

Despite its popularity and success, the RC10GT was eventually discontinued in the mid-2000s as advancements in RC technology and the rise of brushless electric systems began to shift market demand. Team Associated transitioned its focus toward newer models that incorporated these technologies. However, the RC10GT remains a beloved classic, often remembered as one of the vehicles that defined the nitro stadium truck era. Today, it enjoys a cult following among collectors and vintage RC enthusiasts, who continue to celebrate its groundbreaking contributions to the hobby. Which is why we are proud to announce the re-release of this legendary gas truck.

FEATURES

- Authentic replica of the RC10GT Gas Truck Kit originally released in 1993
- Exclusive Gold Aircraft aluminum tub chassis
- Stealth ATC Transmission, optimized for gas truck racing, 2.6:1 reduction
- Powerful rear disk brakes
- Adjustable Slipper clutch
- 2-second, quick fill fuel tank with filter
- Heavy-duty front and rear arms
- Reversible bellcrank / servo-saver steering
- Vintage multi-surface wide front tires
- Vintage Spike rear tires
- 3-piece front and rear wheels
- Original Clear Lexan body
- Gold Anodized, Oil filled shocks
- Ball Differential
- Precision Bearings throughout
- Original release white plastic parts
- Adjustable Turnbuckles for camber and toe
- Aluminum Engine Manifold (Non pull start)
- Polished Exhaust pipe (Non Pull Start)
- 2 Shoe Clutch system and flywheel (non pull start)



SPECIFICATIONS

| | |
|----------------|-------------------|
| Scale | 1:10 |
| Power | Nitro |
| Length | 400mm (15.7") |
| Width | 315mm (12.4") |
| Weight | Varies |
| Wheelbase | 287.02mm (11.30") |
| Internal Ratio | 2.6:1 |

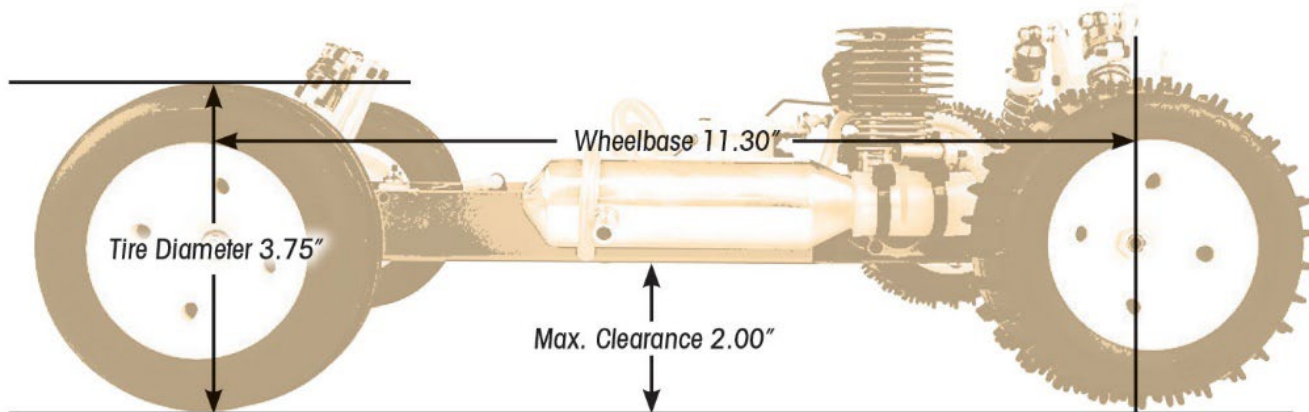

ITEMS NEEDED TO COMPLETE

- .12 or .15 non-pull start engine (O.S. type crank)
- Radio control battery charger
- Starter box
- Nitro fuel
- 2-channel RC surface transmitter and its batteries
- 2-channel receiver
- Receiver battery pack



CATALOG INFORMATION

| UPC | Part No. | Description | MSRP | MAP | Pieces Per Case | Origin | Available |
|--------------|----------|--------------------------------|----------|----------|-----------------|--------|-----------|
| 784695070660 | 7066 | Team Associated RC10GT Classic | \$589.99 | \$399.99 | 6 | TW | February |

Download all zipped photos here: <https://rc10.com/rc10GTzip/> (16MB). Link is active for 30 days.



21062 Bake Pkwy
Lake Forest CA 92630
www.AssociatedElectrics.com

